

しゃ断容量 Breaking Capacity.  
 AC250V-100KA  
 DC250V(L/R10ms)-100KA  
 最大アーク電圧 550V  
 Maximum arc voltage:550V



**Feature/特長**

Trip indicator or micro-switch can be fitted to most Fuses  
 Outstanding performance under repetitive current condition and long life expectancy.

溶断表示ヒューズとマイクロスイッチがオプションで取付けられます。  
 繰り返し電流に強い。  
 BrushとGECとの互換性があります。



**UL仕様 UL Specifications**

Type	Ampere Rating	Pre-arc I <sup>2</sup> t (A <sup>2</sup> S)	Total I <sup>2</sup> t(A <sup>2</sup> S) at AC250V-100KA	Watts Loss (W)	Dimensions (mm)											Carton		
					A	B	C	D	E	F	G	H	W	T	M	(g)	Qty	Fig
250GH-20	20A	20	160	1.8	55	41 ± 3	25	27 max	17.5	9.5	6.5	19	12	2	—	27	20	1
250GH-25	25A	33	270	2.6														
250GH-32	32A	52	410	3.1														
250GH-40	40A	74	600	3.7														
250GH-50	50A	132	1060	5.5														
250GH-63	63A	208	1680	6.5														
250GH-80	80A	370	2800	8.0														
250GH-100	100A	530	4200	11.0														
250GH-125	125A	820	6700	14.0														
250GH-160	160A	1200	9000	18.0	78	57 ± 3	29	33 max	23	14	9	26	20	3	—	76	10	1
250GH-200	200A	2100	15000	24.0														
250GH-250	250A	3300	23000	34.0														
250GH-315	315A	6000	43000	35.0	87	57 ± 3	30	41 max	31	16	11	36	25	3	—	134	10	1
250GH-350	350A	7400	52000	45.0														

警報ヒューズ付きを発注する場合の形式は末尾にSを付けて下さい。250GH-315S  
 ULご注文の際には品名の末尾にULと記入して下さい。250GH-315UL

With indicator, please put on "S" at the end of ampere rating. For example: 250GH-315S  
 When ordering a UL product, please put "UL" at the end of the ampere rating. For example: 250GH-315UL

**スタンダード仕様 Standard Specifications**

Type	Ampere Rating	Pre-arc I <sup>2</sup> t (A <sup>2</sup> S)	Total I <sup>2</sup> t(A <sup>2</sup> S) at AC250V-100KA	Watts Loss (W)	Comparison with Competitors		Dimensions (mm)											Carton		
					BRUSH Types	GEC Types	A	B	C	D	E	F	G	H	W	T	M	(g)	Qty	Fig
250GH-20	20A	20	160	1.8	—	—	55	41 ± 3	25	27 max	17.5	9.5	6.5	19	12	2	—	27	20	1
250GH-25	25A	33	270	2.6	240V-25LET	240V-GSA25														
250GH-32	32A	52	410	3.1	240V-32LET	—														
250GH-35	35A	54	420	3.5	240V-35LET	240V-GSA35														
250GH-40	40A	74	600	3.7	—	—														
250GH-50	50A	132	1060	5.2	240V-50LET	240V-GSA50														
250GH-63	63A	208	1680	6.5	240V-63LET	—														
250GH-80	80A	370	2800	8.0	240V-80LET	—														
250GH-100	100A	530	4200	11.0	240V-100LET	240V-GSA100	78	57 ± 5	29	33	23	14	9	26	20	3	—	76	10	1
250GH-125	125A	820	6700	14.0	240V-125LET	240V-GSD125														
250GH-160	160A	1200	9000	19.0	240V-160LMT	240V-GSA150														
250GH-200	200A	2100	15000	25.0	240V-200LMT	240V-GSA200	87	57 ± 3	30	41 max	31	16	11	36	25	3	—	134	10	1
250GH-250	250A	3300	23000	34.0	240V-250LMT	240V-GSA250														
250GH-315	315A	6000	43000	35.0	240V-315LMT	240V-GSD300	86	61 ± 2	30	46 max	37	13	11	40	30	3	—	180	5	2
250GH-350	350A	7400	52000	45.0	240V-350LMT	240V-GSD350														
250GH-400	400A	11000	75000	45.0	240V-400LMT	240V-GSA400	86	61 ± 2	30	46 max	37	13	11	40	30	6	80	380	5	2
250GH-450	450A	13500	92000	50.0	240V-450LMT	—														
250GHW-500	500A	24000	160000	50.0	240V-500LMMT	240V-GSA500	86	61 ± 2	30	46 max	37	13	11	40	30	6	80	380	5	2
250GHW-630	630A	30000	205000	65.0	240V-630LMMT	240V-GSD600														
250GHW-710	710A	43000	280000	70.0	240V-710LMMT	240V-GSD700														
250GHW-800	800A	53000	355000	80.0	240V-800LMMT	—														

**外形図 Outline Dimensions (m/m)**

fig 1

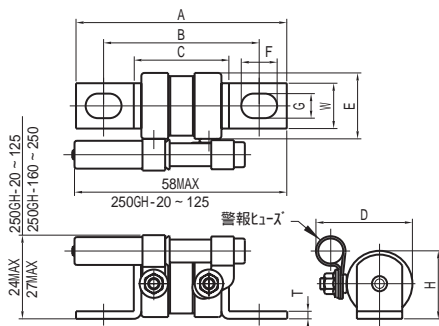
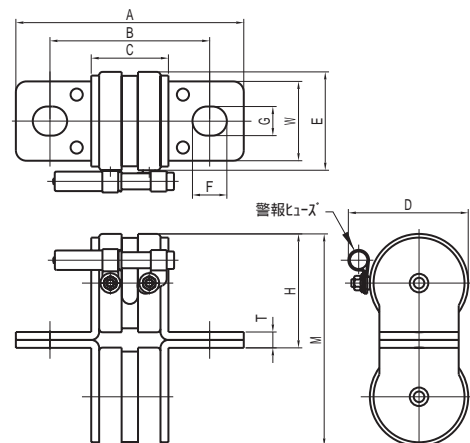
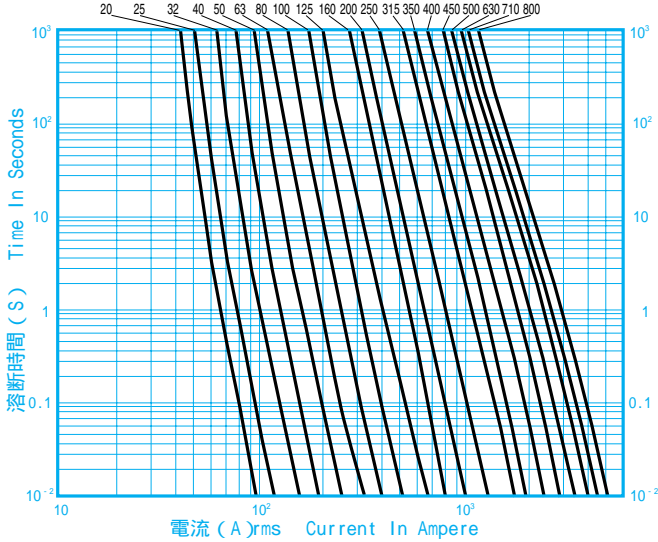

fig 2



# 250GH特性表/Characteristics

溶断時間—電流特性曲線 Melting Time-Current Characteristics Curve.



## Caution

A fuse is easily influenced by its surrounding atmosphere and by the power of the continuous electric current passing through it. To lengthen the life span of your fuses, ensure that your target workload is less than 65% of their rated current.

When using a fuse in a DC circuit, depending on the circuit condition, you may have to use a higher rated voltage fuse than the circuit voltage. (See time constant graph)

If there is a possibility of fusing due to an over loaded current which is less than the fuse rated current in a DC circuit, the fuse should be used in conjunction with other protectors.

## 注意

ヒューズの寿命は使用周囲温度とヒューズに流れる連続電流に影響されます。ヒューズの寿命を延ばす為にヒューズ定格電流の65%以下の電流を連続使用電流として下さい。直流回路に使用する場合、回路条件により回路電圧より高い定格電圧のヒューズを使用しなければならない場合があります。(グラフ時定数参照) 直流回路で定格電流の5倍以内の過電流にて溶断の可能性のある場合は、他の保護機器と併用して使用して下さい。

ヒューズ温度上昇曲線 Temperature Characteristics

試験条件 / The terms of testing

温度測定点	使用導体	mm <sup>2</sup>	定格電流	mm <sup>2</sup>	定格電流
	Applied Conductor		Current Ampere		Current Ampere
 Temperature measuring point	14	20 ~ 40A	150	250 ~ 315A	
	30	50 ~ 63A	240	350 ~ 400A	
	40	70 ~ 80A	300	450 ~ 500A	
	50	100 ~ 125A	400	630A	
	100	160 ~ 200A	600	710 ~ 800A	

直流回路への適用 DC-Operation

Voltage Derating Vs Time Constant

ヒューズを直流回路に使用するときは回路電圧と回路時定数の大きさで選定して下さい。(グラフ参照)

例：定格電圧DC350V、回路時定数30ms、しゃ断時間200msの場合  
この場合は他の定格電圧の高いヒューズを使用して下さい。

When using a fuse in a DC circuit, a fuse should be selected after considering the size of the circuit voltage and the circuit time constant. (see graph below)  
For Example, if you are using a DC 350V rated voltage, 30ms circuit time constant, and 200ms intaerrupted time, then an another fuse with higher rated voltage should be selected.

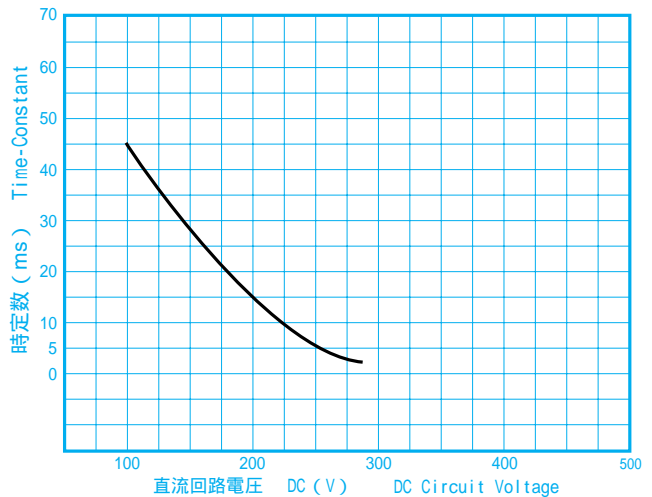
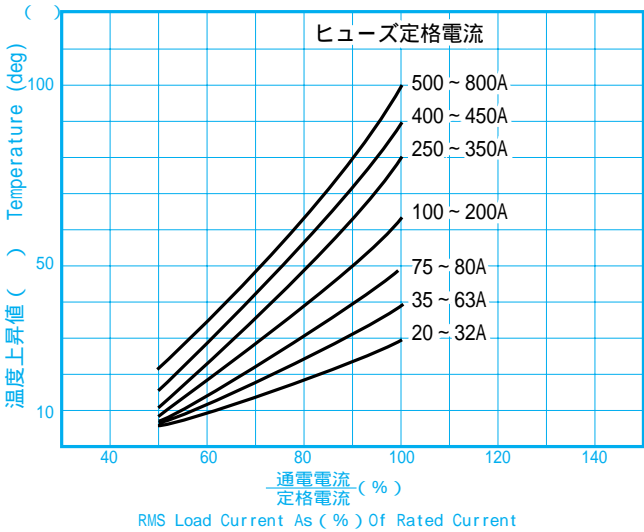

## 電力損失 Power Loss

使用電流が定格電流以下の場合、この時の電力損失の値は次のように求めて下さい。

定格電流時の電力損失(カタログ参照) ×  
使用電流時の係数(グラフ参照)

When the applied current is lower than the rated current, you can measure the value of the power loss as follows:

Power loss of the rated current (see catalogue) ×  
Coefficient (see graph) of the applied current.

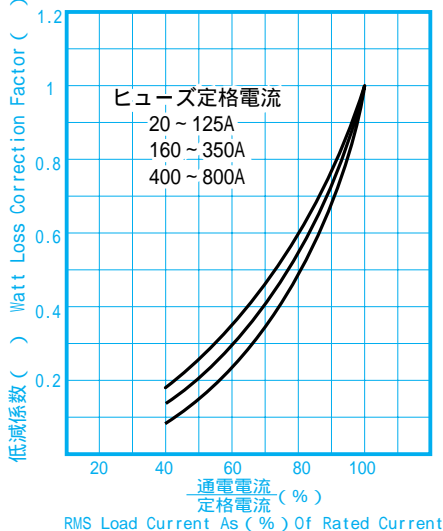

## 使用電圧に対する全しゃ断 I<sup>2</sup>t

RMS Circuit Voltage Vs I<sup>2</sup>t Correction Factor (Total I<sup>2</sup>t × )

使用電圧が定格電圧以下の場合、この時の全しゃ断 I<sup>2</sup>t の値は次のように求めて下さい。

全しゃ断 I<sup>2</sup>t(カタログ参照) ×  
使用電圧時の係数(グラフ参照)

When the applied voltage is lower than the rated voltage, the value of the operating I<sup>2</sup>t can be obtained as follows:

Operating I<sup>2</sup>t value (see catalogue) ×  
Coefficient (see graph) of the applied voltage.

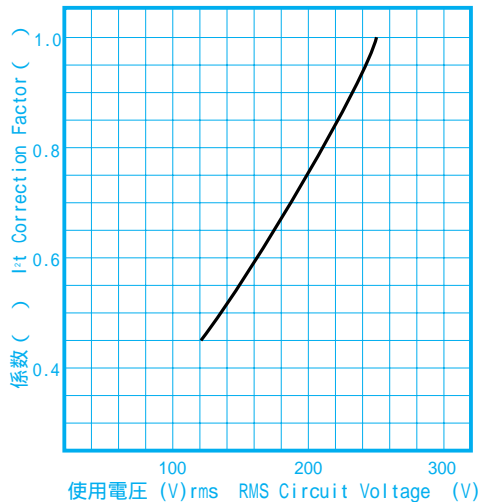

限流特性 Current Limiting Effect Curves

