



Introduction

Induction Motors

Reversible Motors

Synchronous Motors

Torque Motors

Waterlight Motors

Magnetic Brake

Clutch & Brake

Brake Pack

Right-Angle Gearheads

Accessories

Before Using a Standard AC Motor

Synchronous Motors

Additional Information

- Technical ReferenceF-1
- General InformationG-1

Synchronous Motors

Features

Synchronous motors provide rotation at a fixed speed in synchronization with the frequency of the power source, regardless of fluctuation of the load or line voltage. Synchronous speed is 1800 r/min at 60 Hz. It is possible to decrease motor rotation by attaching gearhead.



Safety Standard and CE Marking

Standards	Certification Body	Standards File No.	CE Marking
UL1004 UL519 (4 W Type) UL547 (10~25 W Type)	UL	E64199 (4 W Type) E64197 (10 W~25 W Type)	Low Voltage Directives
CSA C22.2 No. 100 CSA C22.2 No. 77	CSA	LR47296	
EN60950	VDE	5876ÜG (4 W Type) 5877ÜG (10 W~25 W Type)	

• Details of Safety Standards → Page G-2

System Configuration

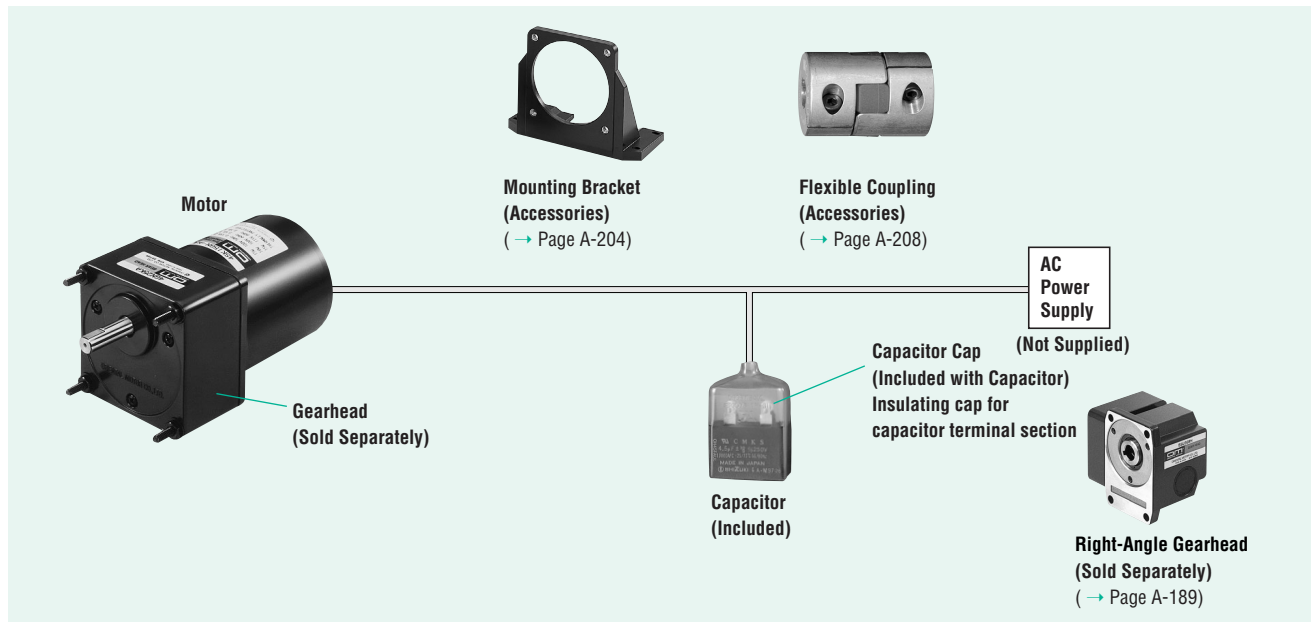

The system configuration shown is an example. Other configurations are available.

Product Number Code

4 S K 15 GN-A UL □

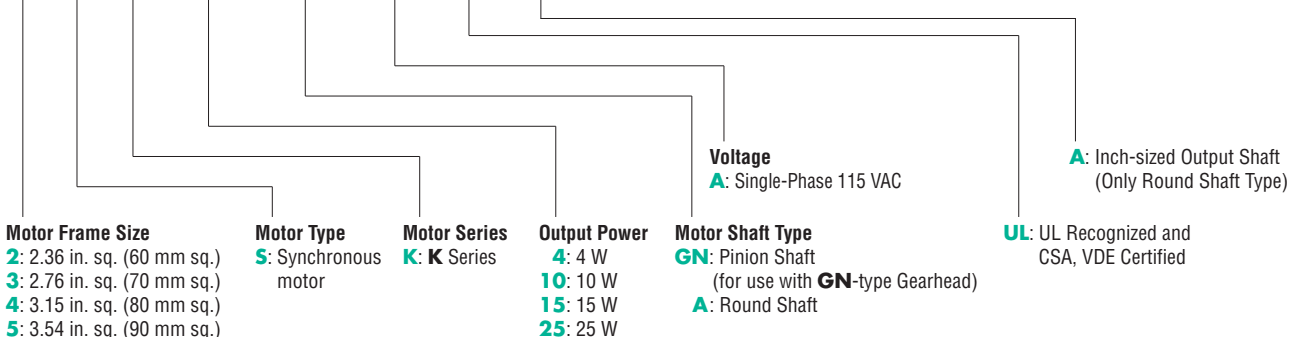

• Gearhead Product Number Code → Page A-16



Specifications — Continuous Rating

Model		Output Power		Voltage	Frequency	Current	Starting Torque		Rated Torque		Rated Speed	Capacitor
Pinion Shaft Type	Round Shaft Type	HP	W	VAC	Hz	A	oz-in	mN·m	oz-in	mN·m	r/min	μF
Ⓜ 2SK4GN-AUL	2SK4A-AULA	1/190	4	115	60	0.24	3.1	22	3.1	22	1800	1.0
Ⓜ 3SK10GN-AUL	3SK10A-AULA	1/75	10	115	60	0.35	7.1	50	7.8	55	1800	1.5
Ⓜ 4SK15GN-AUL	4SK15A-AULA	1/50	15	115	60	0.50	7.8	55	11.5	81	1800	1.5
Ⓜ 5SK25GN-AUL	5SK25A-AULA	1/30	25	115	60	0.75	12	85	19.1	135	1800	3.0

Ⓜ Impedance protected.

Ⓜ Contains a built-in thermal protector. If a motor overheats for any reason, the thermal protector is opened and the motor stops. When the motor temperature drops, the thermal protector closes and the motor restarts. Be sure to turn the motor off before inspecting.

Gearheads (Sold separately)

Parallel Shaft

Gearhead Model	Gear Ratio
2GN□KA	3~180
2GN10XK (Decimal Gearhead)	
3GN□KA	3~180
3GN10XK (Decimal Gearhead)	
4GN□KA	3~180
4GN10XK (Decimal Gearhead)	
5GN□KA	3~180
5GN10XK (Decimal Gearhead)	

Enter the gear ratio in the box (□) within the model name.

Right-Angle

Type	Gearhead Model	Gear Ratio
Hollow Shaft	4GN□RH	3.6~180
	5GN□RH	
Solid Shaft	4GN□RAA	3~180
	5GN□RAA	

Enter the gear ratio in the box (□) within the model name.

Right-Angle Gearheads → Page A-189

General Specifications

Item	Specifications
Insulation Resistance	100 MΩ or more when 500 VDC is applied between the windings and the frame after rated motor operation under normal ambient temperature and humidity.
Dielectric Strength	Sufficient to withstand 1.5 kV at 60 Hz applied between the windings and the frame for 1 minute after rated motor operation under normal ambient temperature and humidity.
Temperature Rise	135 °F (75 °C) or less measured by the resistance change method after rated motor operation.
Insulation Class	UL/CSA Standard Class A [221 °F (105 °C)], EN Standard Class E [248 °F (120 °C)]
Overheat Protection	4 W motor has impedance protection. All others have built-in thermal protector (Automatic return type) Operating temperature, open : 248 °F ± 9 °F (120 °C ± 5 °C) close: 170.6 °F ± 27 °F (77 °C ± 15 °C)
Ambient Temperature Range	14 °F ~ 104 °F (-10 °C ~ +40 °C) (nonfreezing)
Ambient Humidity	85% maximum (noncondensing)
Degree of Protection	IP 20

Gearmotor — Torque Table

Unit = Upper values: lb-in / Lower values: N·m

Model	Speed r/min	600	500	360	300	240	200	144	120	100	72	60	50	36	30	24	20	18	15	12	10
	Gear Ratio	3	3.6	5	6	7.5	9	12.5	15	18	25	30	36	50	60	75	90	100	120	150	180
2SK4GN-AUL / 2GN□KA		0.46	0.56	0.78	0.97	1.15	1.41	1.94	2.3	2.8	3.5	4.2	5.1	6.4	7.6	9.7	11.5	13.2	15	19.4	23
		0.053	0.064	0.089	0.11	0.13	0.16	0.22	0.27	0.32	0.40	0.48	0.58	0.73	0.87	1.1	1.3	1.5	1.7	2.2	2.6
3SK10GN-AUL / 3GN□KA		1.15	1.41	1.94	2.3	2.9	3.5	4.9	5.9	7	8.8	10.6	12.3	15.9	19.4	23	29	31	38	44	44
		0.13	0.16	0.22	0.27	0.33	0.40	0.56	0.67	0.80	1.0	1.2	1.4	1.8	2.2	2.7	3.3	3.6	4.4	5	5
4SK15GN-AUL / 4GN□KA		1.77	2.1	2.9	3.4	4.3	5.2	7.2	8.6	10.6	13.2	15.9	18.5	23	28	35	42	46	56	70	70
		0.20	0.24	0.33	0.39	0.49	0.59	0.82	0.98	1.2	1.5	1.8	2.1	2.7	3.2	4.0	4.8	5.3	6.4	8	8
5SK25GN-AUL / 5GN□KA		2.9	3.4	4.8	5.8	7.2	8.6	12.3	14.1	17.7	22	26	30	39	46	59	70	78	88	88	88
		0.33	0.39	0.55	0.66	0.82	0.98	1.4	1.6	2.0	2.5	3.0	3.5	4.5	5.3	6.7	8.0	8.9	10	10	10

- Gearheads are sold separately.
- Enter the gear ratio in the box (□) within the model name.
- A colored background indicates gear shaft rotation in the same direction as the motor shaft; a white background indicates rotation in the opposite direction.
- The speed is calculated by dividing the motor's speed (60 Hz: 1800 r/min) by the gear ratio.
- The permissible torque with a decimal gearhead with a gear ratio of 10:1 is :
 - 2GN□KA**: 26 lb-in/3 N·m
 - 3GN□KA**: 44 lb-in / 5 N·m
 - 4GN□KA**: 70 lb-in/8 N·m (for 1/25~1/36: 52 lb-in/6 N·m)
 - 5GN□KA**: 88 lb-in/10 N·m

Permissible Overhung Load and Permissible Thrust Load

Motor (Round Shaft Type) → A-11

Gearhead → A-11

Permissible Load Inertia J for Gearhead

Motor (Round Shaft Type) → A-12

Gearhead → A-12

Dimensions Scale 1/4, Unit = inch (mm)

Mounting screws are included with gearheads.

Dimensions for screws → A-223

Motor/Gearhead

2SK4GN-AUL/2GN□KA

Motor Weight: 1.54 lb. (0.7 kg)

Gearhead Weight: 0.88 lb. (0.4 kg)

DXF A004AU (**2GN3KA~18KA**),
A004BU (**2GN25KA~180KA**)

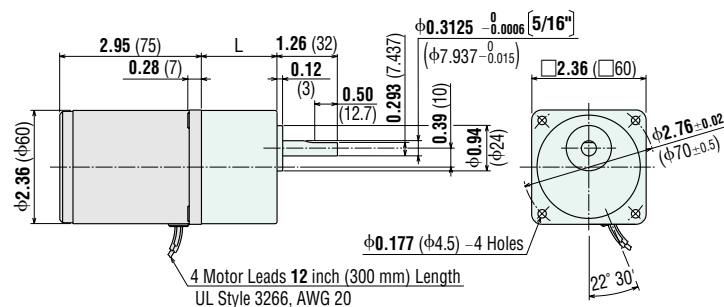

2GN3KA~18KA: L=1.18 (30)
2GN25KA~180KA: L=1.57 (40)

● Motor/Gearhead

4SK15GN-AUL/4GN□KA

Weight: 3.3 lb. (1.5 kg)
 Gearhead Weight: 1.43 lb. (0.65 kg)

DXF A014AU (4GN3KA~18KA),
 A014BU (4GN25KA~180KA)

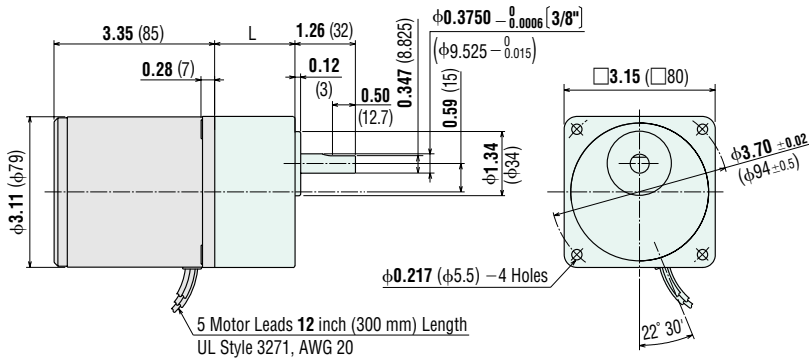

4GN3KA~18KA: L = 1.26 (32)
4GN25KA~180KA: L = 1.67 (42.5)

● Round Shaft Type

4SK15A-AULA

Weight: 3.3 lb. (1.5 kg)

DXF A327U

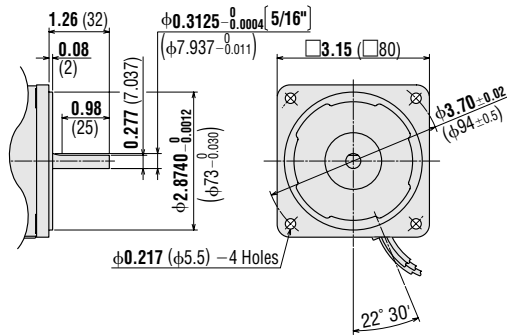

● Decimal Gearhead

(For 4SK15GN-AUL)

4GN10XK

Weight: 0.88 lb. (0.4 kg)

DXF A013

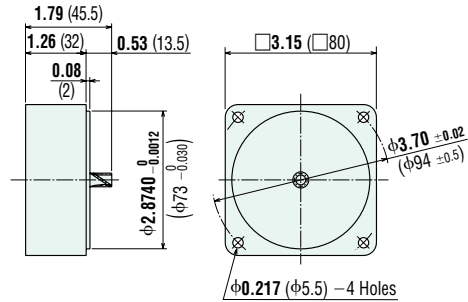

● Motor/Gearhead

5SK25GN-AUL/5GN□KA

Motor Weight: 5.5 lb. (2.5 kg)
 Gearhead Weight: 3.3 lb. (1.5 kg)

DXF A019AU (5GN3KA~18KA),
 A019BU (5GN25KA~180KA)

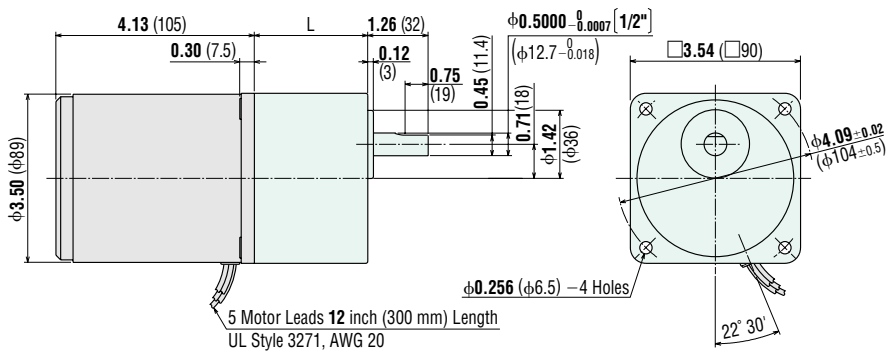

5GN3KA~18KA: L = 1.65 (42)
5GN25KA~180KA: L = 2.36 (60)

