



Introduction

Induction Motors

Reversible Motors

Synchronous Motors

Torque Motors

Waterright Motors

Magnetic Brake

Clutch & Brake

Brake Pack

Right-Angle Gearheads

Accessories

Before Using a Standard AC Motor

Right-Angle Gearheads

Additional Information

- Technical Reference.....F-1
- General Information.....G-1

Right-Angle Gearheads

Right-Angle gearheads are flange-mounted gearheads that use worm gears and special helical gears. They allow motors to be installed at right angles to the axis of equipment such as belt conveyors. They are available in hollow shaft (**RH**) and solid shaft (**RAA**) models and are ideal for keeping equipment compact.

Features

Right-angle gearheads with mounting sizes of 3.15 in. sq. (for 25 W) or 3.54 in. sq. (for 40 W) are available for the **GN** pinion and mounting sizes of 3.54 in. sq. (for 60 or 90 W) are available for the **GU** pinion.

Eleven gear ratios are available from 3.6:1 to 180:1. The maximum permissible torques are the same as for ordinary parallel shaft gearheads.

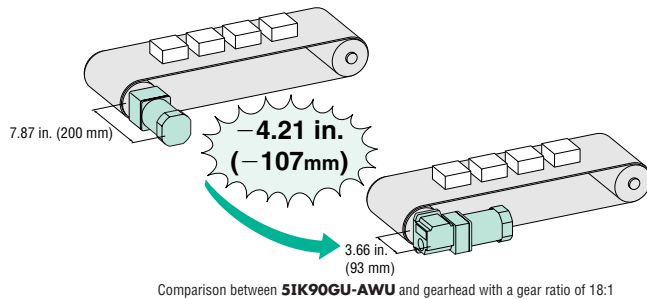

Hollow shaft gearheads allow additional space savings and simpler mechanism designs since they do not require couplings for mounting*.

* Mounting Using Torque Arm

Usually, hollow shaft gearheads are locked with a torque arm when mounted so the gearhead does not rotate from the reactive force of the load. The torque arm is available as an accessory for the **5GU□RH**, **BHF** series and **BH** series. Torque arm → Page A-207

Applicable Products

Gearheads can be used with pinion shaft type motors listed below.

Motors	Series	Output Power
Induction Motor	World K Series (Page A-28~A-53)	25 W, 40 W, 60 W, 90 W
Reversible Motor	World K Series (Page A-82~A-101)	
Electromagnetic Brake Motors	World K Series (Page A-142~A-162)	
Synchronous Motors	K Series (Page A-103)	15 W, 25 W
Speed Control Systems	AXU Series (Page B-46)	25 W, 40 W, 60 W, 90 W
	US Series (Page B-116)	25 W, 40 W, 60 W, 90 W
	ES Series Speed Control Systems (Page B-86)	25 W, 40 W

- This product can be used for other products besides those listed.
AC Motors with matching mounting frame sizes can be used with right angle gearheads.
(Example) **4IK25GN-AWU** → **4GN□RH** (or **4GN□RAA**)

Product Number Code

5 GU 18 R AA

Shaft Type

AA: Solid type and inch-sized output shaft
H: Hollow type

R: Right-Angle Gearhead

GN: GN pinion gear
GU: GU pinion gear

Gearhead Frame Size

4: 3.15 in. sq. (80 mm sq.)
5: 3.54 in. sq. (90 mm sq.)

Product Line

Shaft Type	Gearhead Model
Hollow Shaft	4GN3.6RH ~ 4GN180RH
	5GN3.6RH ~ 5GN180RH
	5GU3.6RH ~ 5GU180RH
Solid Shaft	4GN3.6RAA ~ 4GN180RAA
	5GN3RAA ~ 5GN180RAA
	5GU3RAA ~ 5GU180RAA

Specifications

Gearhead Model	Gear Ratio	Maximum Permissible Torque		Permissible Overhung Load		lb. N		Permissible Thrust Load	
		lb-in	N·m	0.39 in. (10 mm) from shaft end	0.79 in. (20 mm) from shaft end	lb.	N	lb.	N
4GN□RH	3.6~180	70	8	56	250 *	49	220 *	22	100
5GN□RH	3.6~180	88	10	78	350 *	69	310 *	45	200
5GU□RH	3.6~180	177	20	126	560 *	112	500 *	56	250
4GN□RAA	3.6~18	70	8	22	100	33	150	22	100
	30~180			45	200	67	300		
5GN□RAA	3~18	88	10	56	250	78	350	45	200
	25~180			67	300	101	450		
	3~9			90	400	112	500		
5GU□RAA	12.5~25	177	20	101	450	135	600	56	250
	30~180			112	500	157	700		

* Overhung load values for hollow shaft models are distances from the flange mounting surface.

● Enter the gear ratio in the box (□) within the model name.

Note:

● Unlike most worm gear mechanisms, the right-angle gear does not have self-locking capabilities.

Gearmotor–Torque Table

The permissible torques shown on pages A-196 to A-202 cover most motor combinations. For motor combinations not covered, use the efficiency value in the table below for your calculations. When making a selection, remember that the transfer efficiency at startup is lower than at the rated speed.

$$\text{Permissible torque} \dots \dots T_G = T_M \times i \times \eta$$

T_G : Permissible torque of gearhead

T_M : Motor torque

i : Gearhead gear ratio

η : Gearhead efficiency

● Gearhead Efficiency

Gear Ratio		3.6	6	9	15	18	30	36	60	90	120	180
4GN□RH	Rating	40 %		50 %		60 %						
	Startup	40 %		50 %		54 %						
5GN□RH	Rating	50 %		68 %			60 %					
	Startup	50 %		60 %			54 %					
5GU□RH	Rating	50 %		68 %			60 %			50 %		
	Startup	50 %		60 %			54 %			45 %		
4GN□RAA	Rating	50 %			60 %							
	Startup	50 %			54 %							

Gear Ratio		3	3.6	5	6	7.5	9	12.5	15	18	25	30	36	50	60	75	90	100	120	150	180	
5GN□RAA	Rating	68 %					60 %															
	Startup	60 %					54 %															
5GU□RAA	Rating	68 %					60 %										50 %					
	Startup	60 %					54 %										45 %					

● Enter the gear ratio in the box (□) within the model name.

Calculating Permissible Overhung Load for Hollow Shaft Models

When the end of the shaft being driven is supported as in the figure below, calculate the permissible overhung load using the following equations. (This mechanism is the most demanding in terms of overhung load.)

4GN□RH

$$\text{Permissible overhung load } W [\text{lb. (N)}] = \frac{2.34 \text{ in. (59.5 mm)}}{2.34 \text{ in. (59.5 mm)} + L_p} \times 66 \text{ lb. (295 N)}^*$$

* 66 lb. (295 N): Permissible overhung load at flange mounting surface

5GN□RH

$$\text{Permissible overhung load } W [\text{lb. (N)}] = \frac{2.76 \text{ in. (70 mm)}}{2.76 \text{ in. (70 mm)} + L_p} \times 90 \text{ lb. (400 N)}^*$$

* 90 lb. (400 N): Permissible overhung load at flange mounting surface

5GU□RH

$$\text{Permissible overhung load } W [\text{lb. (N)}] = \frac{2.70 \text{ in. (68.5 mm)}}{2.70 \text{ in. (68.5 mm)} + L_p} \times 145 \text{ lb. (645 N)}^*$$

* 145 lb. (645 N): Permissible overhung load at flange mounting surface

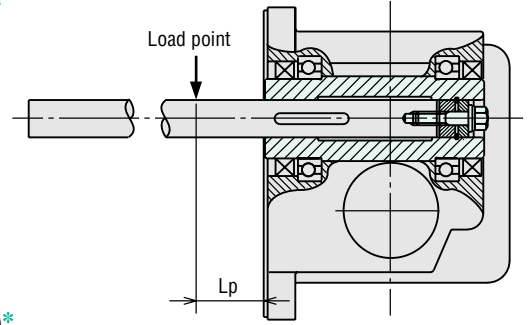

Lp [in. (mm)]: Distance from flange mounting surface to overhung load point

Dimensions Scale 1/4, Unit = inch (mm)

Mounting screws are included with gearheads. Dimensions for screws → Page A-223

Enter the gear ratio in the box (□) within the model name.

Hollow Shaft

4GN□RH

Weight: 3.5 lb. (1.6 kg)

DXF A254

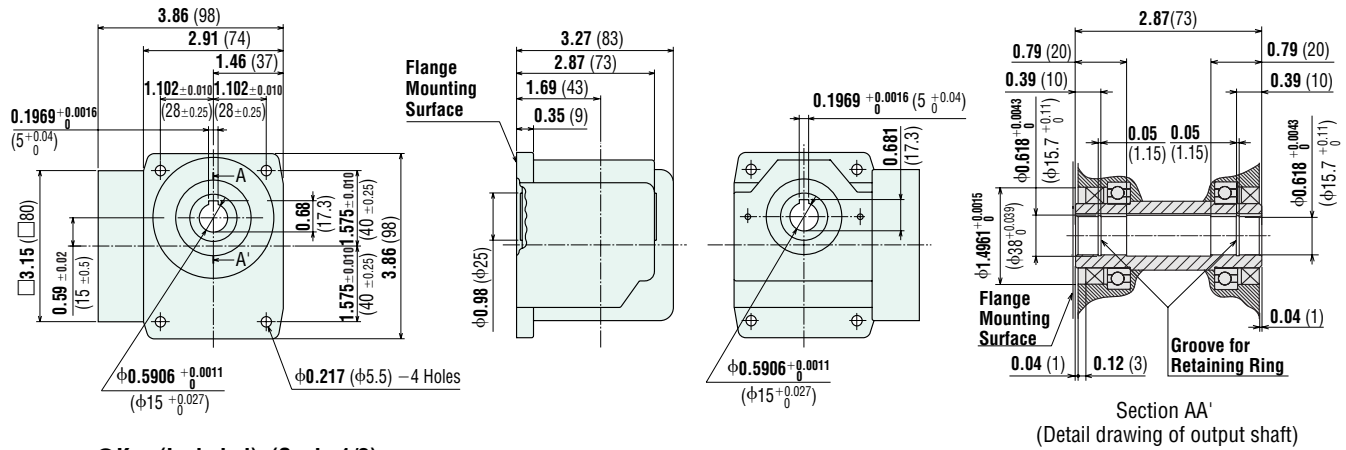

Key (Included) (Scale 1/2)

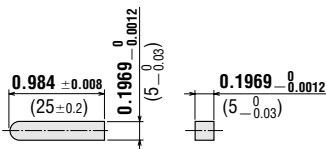

◆ Hollow Shaft

5GN□RH

Weight: 4.4 lb. (2.0 kg)

DXF A229

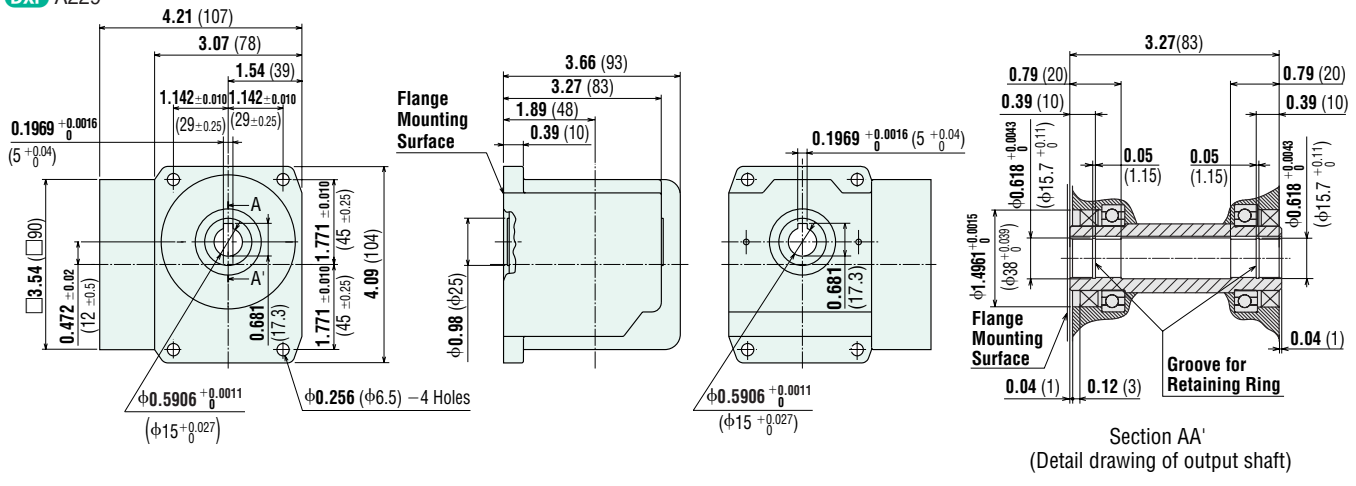

●Key (Included) (Scale 1/2)

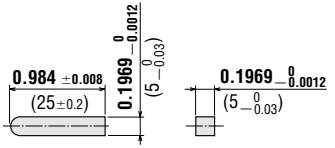

◆ Hollow Shaft

5GU□RH

Weight: 5.5 lb. (2.5 kg)

DXF A230

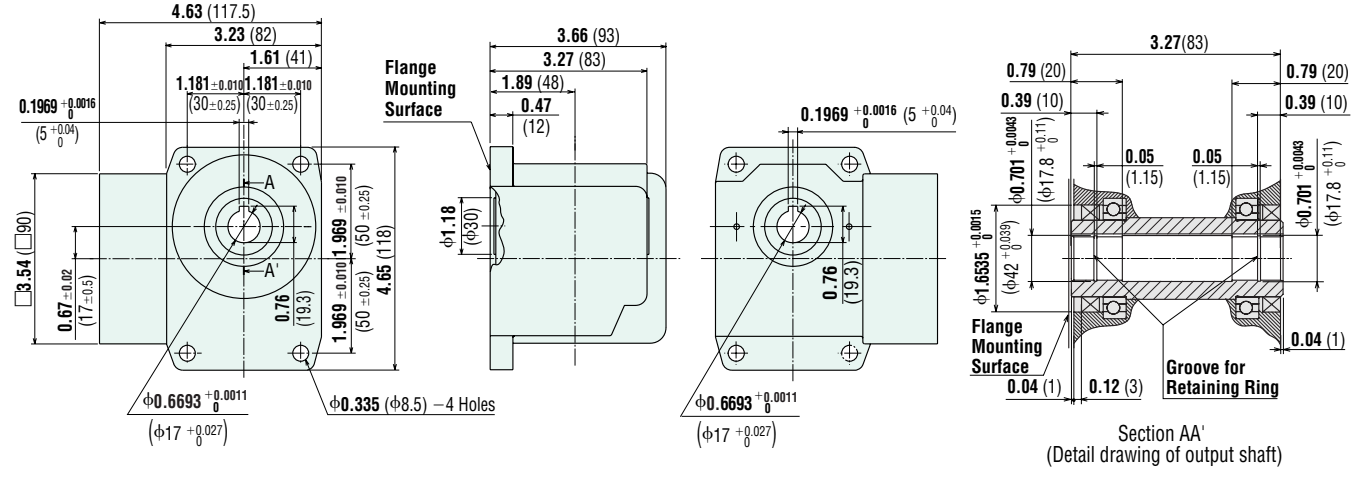

●Key (Included) (Scale 1/2)

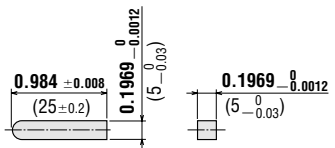

■ Dimensions of the Gearhead Mounting Surface

Allow at least 0.31 inch (8 mm) for the thickness of the mounting plate and use screws of the appropriate length.

● Cross Section Unit = inch (mm)

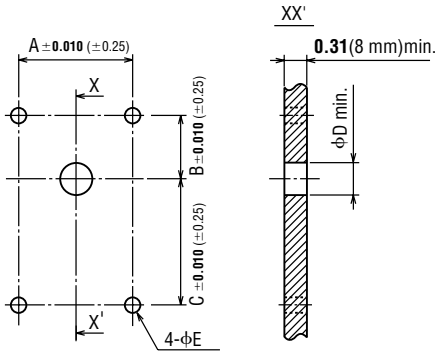

		Unit = inch (mm)				
Shaft Type	Model	A	B	C	φD	φE
Hollow Shaft	4GN□RH	2.20 (56)	0.98 (25)	2.17 (55)	φ0.59 (φ15)	φ0.22 (φ5.5)
	5GN□RH	2.28 (58)	1.30 (33)	2.24 (57)	φ0.59 (φ15)	φ0.26 (φ6.5)
	5GU□RH	2.36 (60)	1.30 (33)	2.64 (67)	φ0.67 (φ17)	φ0.33 (φ8.5)
Solid Shaft	4GN□RAA	2.20 (56)	0.98 (25)	2.17 (55)	φ1.38 (φ35)	φ0.22 (φ5.5)
	5GN□RAA	2.28 (58)	1.30 (33)	2.24 (57)	φ1.46 (φ37)	φ0.27 (φ6.8)
	5GU□RAA	2.36 (60)	1.30 (33)	2.64 (67)	φ1.38 (φ35)	φ0.33 (φ8.5)

● Enter the gear ratio in the box(□) within the model name.

■ Mounting Method of Hollow Shaft Type Gearheads

● Example of Mounting the Load

The diagrams below show how to mount loads depending on the shape of the shaft. Apply a coating of molybdenum disulfide or similar grease to the inner diameter of the load shaft to prevent binding. Recommended load shaft dimensions are shown to the right.

Unit = inch (mm)		
Model	Inner diameter of hollow shaft H8	Recommended load shaft diameter h7
4GN□RH	$\phi 0.5906^{+0.0011}_0 (\phi 15^{+0.027}_0)$	$\phi 0.5906^{0}_{-0.0007} (\phi 15^{0}_{-0.018})$
5GN□RH	$\phi 0.5906^{+0.0011}_0 (\phi 15^{+0.027}_0)$	$\phi 0.5906^{0}_{-0.0007} (\phi 15^{0}_{-0.018})$
5GU□RH	$\phi 0.6693^{+0.0011}_0 (\phi 17^{+0.027}_0)$	$\phi 0.6693^{0}_{-0.0007} (\phi 17^{0}_{-0.018})$

● Enter the gear ratio in the box (□) within the model name.

● Stepped-Down Shafts

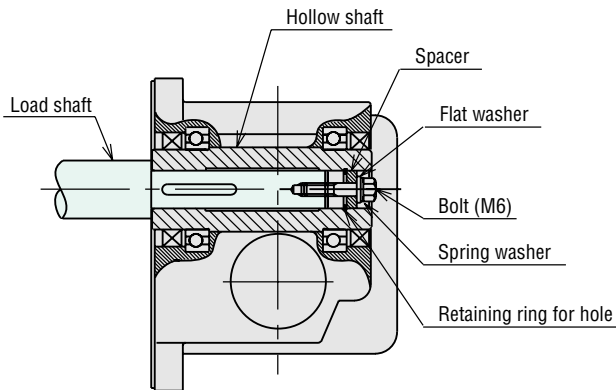

● Straight Load Shafts

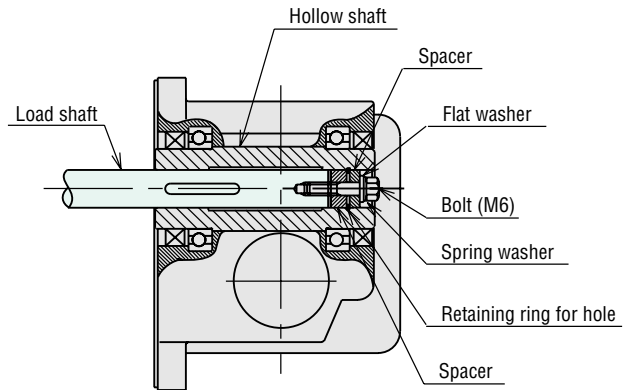

Note: If the bolt extends more than 0.16 inch (4 mm) from the end of the hollow shaft, a safety cover can not be installed. (RH model hollow shaft gearheads include safety covers.)

■ Gearmotor — Torque Table

- The speed is calculated by dividing the motor's synchronous speed (60 Hz: 1800 r/min) by the gear ratio. The actual speed is 2 ~20% less than the listed value, depending on the size of the load.
- The efficiency of the gear assembly at startup is lower than the rating, so output torque is lower.
- Enter the gear ratio in the box (□) within the model name.

● World K Series Induction Motors (General Purpose)

◆ Hollow Shaft Single-Phase 115 VAC 60 Hz

All output shafts rotate opposite to the direction of motor shaft rotation.

Unit = Upper values: lb-in/Lower values: N-m

Model	Speed r/min	500	300	200	120	100	60	50	30	20	15	10
Motor/Gearhead	Gear Ratio	3.6	6	9	15	18	30	36	60	90	120	180
4IK25GN-AWU /4GN□RH	Rating	2.1 0.24	3.6 0.41	6.8 0.77	13.2 1.5	15.9 1.8	27 3.1	32 3.7	53 6.1	70 8	70 8	70 8
	Startup	1.5 0.17	2.5 0.29	4.7 0.54	8.5 0.97	10.6 1.2	16.8 1.9	20 2.3	34 3.9	51 5.8	69 7.8	70 8
5IK40GN-AWU /5GN□RH	Rating	4.1 0.47	6.9 0.78	14.1 1.6	23 2.7	28 3.2	41 4.7	49 5.6	83 9.4	88 10	88 10	88 10
	Startup	3.1 0.36	5.3 0.6	9.7 1.1	15.9 1.8	19.4 2.2	28 3.2	34 3.9	57 6.5	85 9.7	88 10	88 10
5IK60GU-AWU /5GU□RH	Rating	6.4 0.73	10.6 1.2	22 2.5	36 4.1	44 5.0	64 7.3	76 8.7	129 14.6	177 20	177 20	177 20
	Startup	5.1 0.58	8.4 0.96	15 1.7	25 2.9	30 3.5	46 5.2	54 6.2	92 10.4	138 15.6	153 17.3	177 20
5IK90GU-AWU /5GU□RH	Rating	9.7 1.1	15.9 1.8	31 3.6	53 6.0	63 7.2	92 10.5	111 12.6	177 20	177 20	177 20	177 20
	Startup	7.1 0.81	12.3 1.4	21 2.4	36 4.1	43 4.9	64 7.3	76 8.7	129 14.6	177 20	177 20	177 20

◆ Solid Shaft Single-Phase 115 VAC 60 Hz

All output shafts rotate opposite to the direction of motor shaft rotation.

Unit = Upper values: lb-in/Lower values: N-m

Model	Speed r/min	500	300	200	120	100	60	50	30	20	15	10
Motor/Gearhead	Gear Ratio	3.6	6	9	15	18	30	36	60	90	120	180
4IK25GN-AWU /4GN□RAA	Rating	2.7 0.31	4.5 0.51	6.8 0.77	13.2 1.5	15.9 1.8	27 3.1	32 3.7	53 6.1	70 8	70 8	70 8
	Startup	1.94 0.22	3.1 0.36	4.7 0.54	8.5 0.97	10.6 1.2	16.8 1.9	20 2.3	34 3.9	51 5.8	69 7.8	70 8

Unit = Upper values: lb-in/Lower values: N-m

Model	Speed r/min	600	500	360	300	240	200	144	120	100	72	60	50	36	30	24	20	18	15	12	10
Motor/Gearhead	Gear Ratio	3	3.6	5	6	7.5	9	12.5	15	18	25	30	36	50	60	75	90	100	120	150	180
5IK40GN-AWU /5GN□RAA	Rating	4.6 0.53	5.6 0.64	7.7 0.88	9.7 1.1	11.5 1.3	14.1 1.6	19.4 2.2	23 2.7	28 3.2	34 3.9	41 4.7	49 5.6	69 7.8	83 9.4	88 10	88 10	88 10	88 10	88 10	88 10
	Startup	3.1 0.36	3.8 0.43	5.3 0.6	6.3 0.72	7.9 0.9	9.7 1.1	13.2 1.5	15.9 1.8	19.4 2.2	23 2.7	28 3.2	34 3.9	47 5.4	57 6.5	71 8.1	85 9.7	88 10	88 10	88 10	88 10
5IK60GU-AWU /5GU□RAA	Rating	7.3 0.83	8.7 0.99	12.3 1.4	15 1.7	18.5 2.1	22 2.5	30 3.4	36 4.1	44 5.0	61 6.9	64 7.3	76 8.7	106 12	129 14.6	159 18	177 20	177 20	177 20	177 20	177 20
	Startup	5.1 0.58	6.1 0.69	8.4 0.96	10.6 1.2	12.3 1.4	15 1.7	21 2.4	25 2.9	30 3.5	42 4.8	46 5.2	54 6.2	76 8.6	92 10.4	115 13	138 15.6	153 17.3	153 17.3	177 20	177 20
5IK90GU-AWU /5GU□RAA	Rating	10.6 1.2	12.3 1.4	17.7 2.0	21 2.4	26 3.0	31 3.6	44 5.0	53 6.0	63 7.2	87 9.9	92 10.5	111 12.6	155 17.6	177 20	177 20	177 20	177 20	177 20	177 20	177 20
	Startup	7.1 0.81	8.5 0.97	12.3 1.4	14.1 1.6	14.1 1.6	21 2.4	30 3.4	36 4.1	43 4.9	60 6.8	64 7.3	76 8.7	107 12.2	129 14.6	161 18.2	177 20	177 20	177 20	177 20	177 20

● **World K Series Reversible Motors (General Purpose)**

◆ **Hollow Shaft Single-Phase 115 VAC 60 Hz**

All output shafts rotate opposite to the direction of motor shaft rotation.

Unit = Upper values: lb-in/Lower values: N·m

Model	Speed r/min	500	300	200	120	100	60	50	30	20	15	10
Motor/Gearhead	Gear Ratio	3.6	6	9	15	18	30	36	60	90	120	180
4RK25GN-AWU /4GN□RH	Rating	2.1 0.24	3.6 0.41	6.8 0.77	13.2 1.5	15.9 1.8	27 3.1	32 3.7	53 6.1	70 8	70 8	70 8
	Startup	1.77 0.2	3.0 0.34	5.5 0.63	9.7 1.1	12.3 1.4	20 2.3	23 2.7	39 4.5	60 6.8	70 8	70 8
5RK40GN-AWU /5GN□RH	Rating	4.3 0.49	7.1 0.81	15 1.7	24 2.8	29 3.3	43 4.9	51 5.8	85 9.7	88 10	88 10	88 10
	Startup	4.1 0.47	6.9 0.78	12.3 1.4	20 2.3	24 2.8	37 4.2	45 5.1	74 8.4	88 10	88 10	88 10
5RK60GU-AWU /5GU□RH	Rating	6.4 0.73	10.6 1.2	22 2.5	36 4.1	44 5.0	64 7.3	76 8.7	129 14.6	177 20	177 20	177 20
	Startup	6.0 0.68	9.7 1.1	18.5 2.1	30 3.4	36 4.1	54 6.2	65 7.4	108 12.3	163 18.5	177 20	177 20
5RK90GU-AWU /5GU□RH	Rating	9.7 1.1	15.9 1.8	31 3.6	53 6.0	63 7.2	92 10.5	111 12.6	177 20	177 20	177 20	177 20
	Startup	9.7 1.1	15.9 1.8	28 3.2	46 5.3	56 6.4	84 9.6	101 11.5	169 19.1	177 20	177 20	177 20

◆ **Solid Shaft Single-Phase 115 VAC 60 Hz**

All output shafts rotate opposite to the direction of motor shaft rotation.

Unit = Upper values: lb-in/Lower values: N·m

Model	Speed r/min	500	300	200	120	100	60	50	30	20	15	10
Motor/Gearhead	Gear Ratio	3.6	6	9	15	18	30	36	60	90	120	180
4RK25GN-AWU /4GN□RAA	Rating	2.7 0.31	4.5 0.51	6.8 0.77	13.2 1.5	15.9 1.8	27 3.1	32 3.7	53 6.1	70 8	70 8	70 8
	Startup	2.2 0.25	3.7 0.42	5.5 0.63	9.7 1.1	12.3 1.4	20 2.3	23 2.7	39 4.5	60 6.8	70 8	70 8

Unit = Upper values: lb-in/Lower values: N·m

Model	Speed r/min	600	500	360	300	240	200	144	120	100	72	60	50	36	30	24	20	18	15	12	10
Motor/Gearhead	Gear Ratio	3	3.6	5	6	7.5	9	12.5	15	18	25	30	36	50	60	75	90	100	120	150	180
5RK40GN-AWU /5GN□RAA	Rating	4.8 0.55	5.8 0.66	8.1 0.92	9.7 1.1	12.3 1.4	15 1.7	20 2.3	24 2.8	29 3.3	36 4.1	43 4.9	51 5.8	71 8.1	85 9.7	88 10	88 10	88 10	88 10	88 10	88 10
	Startup	4.1 0.47	4.9 0.56	6.9 0.78	8.3 0.94	10.6 1.2	12.3 1.4	17.7 2.0	20 2.3	24 2.8	30 3.5	37 4.2	45 5.1	61 7.0	74 8.4	88 10	88 10	88 10	88 10	88 10	88 10
5RK60GU-AWU /5GU□RAA	Rating	7.3 0.83	8.7 0.99	12.3 1.4	15 1.7	18.5 2.1	22 2.5	30 3.4	36 4.1	44 5.0	61 6.9	76 7.3	107 8.7	129 12.2	161 14.6	177 18.2	177 20	177 20	177 20	177 20	177 20
	Startup	6.0 0.68	7.2 0.82	9.7 1.1	12.3 1.4	15 1.7	18.5 2.1	25 2.9	30 3.4	36 4.1	50 5.7	54 6.2	65 7.4	91 10.3	108 12.3	136 15.4	163 18.5	177 20	177 20	177 20	177 20
5RK90GU-AWU /5GU□RAA	Rating	10.6 1.2	12.3 1.4	17.7 2.0	21 2.4	26 3.0	31 3.6	44 5.0	53 6.0	63 7.2	87 9.9	92 11.5	111 12.6	155 17.6	177 20	177 20	177 20	177 20	177 20	177 20	177 20
	Startup	9.7 1.1	11.5 1.3	15.9 1.8	18.5 2.1	23 2.7	28 3.2	38 4.4	46 5.3	56 6.4	78 8.9	84 9.6	101 11.5	140 15.9	169 19.1	177 20	177 20	177 20	177 20	177 20	177 20

Introduction

Induction Motors

Reversible Motors

Synchronous Motors

Torque Motors

Waterlight Motors

Magnetic Brake

Clutch & Brake

Brake Pack

Right-Angle Gearheads

Accessories

Before Using a Standard AC Motor

● **World K Series Electromagnetic Motors (General Purpose)**

◆ **Hollow Shaft Single-Phase 115 VAC 60 Hz**

All output shafts rotate opposite to the direction of motor shaft rotation.

Unit = Upper values: lb-in/Lower values: N-m

Model	Speed r/min	500	300	200	120	100	60	50	30	20	15	10
Motor/Gearhead	Gear Ratio	3.6	6	9	15	18	30	36	60	90	120	180
4RK25GN-AWMU /4GN□RH	Rating	2.1 0.24	3.6 0.41	6.8 0.77	13.2 1.5	15.9 1.8	27 3.1	32 3.7	53 6.1	70 8	70 8	70 8
	Startup	1.77 0.2	3.0 0.34	5.5 0.63	9.7 1.1	12.3 1.4	20 2.3	23 2.7	39 4.5	60 6.8	70 8	70 8
5RK40GN-AWMU /5GN□RH	Rating	4.3 0.49	7.1 0.81	15 1.7	24 2.8	29 3.3	43 4.9	51 5.8	85 9.7	88 10	88 10	88 10
	Startup	4.1 0.47	6.9 0.78	12.3 1.4	20 2.3	24 2.8	37 4.2	45 5.1	74 8.4	88 10	88 10	88 10
5RK60GU-AWMU /5GU□RH	Rating	6.4 0.73	10.6 1.2	22 2.5	36 4.1	44 5.0	64 7.3	76 8.7	129 14.6	177 20	177 20	177 20
	Startup	6.0 0.68	9.7 1.1	18.5 2.1	30 3.4	36 4.1	54 6.2	65 7.4	108 12.3	163 18.5	177 20	177 20
5RK90GU-AWMU /5GU□RH	Rating	9.7 1.1	15.9 1.8	31 3.6	53 6.0	63 7.2	92 10.5	111 12.6	177 20	177 20	177 20	177 20
	Startup	9.7 1.1	15.9 1.8	28 3.2	46 5.3	56 6.4	84 9.6	101 11.5	169 19.1	177 20	177 20	177 20

◆ **Solid Shaft Single-Phase 115 VAC 60 Hz**

All output shafts rotate opposite to the direction of motor shaft rotation.

Unit = Upper values: lb-in/Lower values: N-m

Model	Speed r/min	500	300	200	120	100	60	50	30	20	15	10
Motor/Gearhead	Gear Ratio	3.6	6	9	15	18	30	36	60	90	120	180
4RK25GN-AWMU /4GN□RAA	Rating	2.7 0.31	4.5 0.51	6.8 0.77	13.2 1.5	15.9 1.8	27 3.1	32 3.7	53 6.1	70 8	70 8	70 8
	Startup	2.2 0.25	3.7 0.42	5.5 0.63	9.7 1.1	12.3 1.4	20 2.3	23 2.7	39 4.5	60 6.8	70 8	70 8

Unit = Upper values: lb-in/Lower values: N-m

Model	Speed r/min	600	500	360	300	240	200	144	120	100	72	60	50	36	30	24	20	18	15	12	10
Motor/Gearhead	Gear Ratio	3	3.6	5	6	7.5	9	12.5	15	18	25	30	36	50	60	75	90	100	120	150	180
5RK40GN-AWMU /5GN□RAA	Rating	4.8 0.55	5.8 0.66	8.1 0.92	9.7 1.1	12.3 1.4	15 1.7	20 2.3	24 2.8	29 3.3	36 4.1	43 4.9	51 5.8	71 8.1	85 9.7	88 10	88 10	88 10	88 10	88 10	88 10
	Startup	4.1 0.47	4.9 0.56	6.9 0.78	8.3 0.94	10.6 1.2	12.3 1.4	17.7 2.0	20 2.3	24 2.8	30 3.5	37 4.2	45 5.1	61 7.0	74 8.4	88 10	88 10	88 10	88 10	88 10	88 10
5RK60GU-AWMU /5GU□RAA	Rating	7.3 0.83	8.7 0.99	12.3 1.4	15 1.7	18.5 2.1	22 2.5	30 3.4	36 4.1	44 5.0	61 6.9	64 7.3	76 8.7	107 12.2	129 14.6	161 18.2	177 20	177 20	177 20	177 20	177 20
	Startup	6.0 0.68	7.2 0.82	9.7 1.1	12.3 1.4	15 1.7	18.5 2.1	25 2.9	30 3.4	36 4.1	50 5.7	54 6.2	65 7.4	91 10.3	108 12.3	136 15.4	163 18.5	177 20	177 20	177 20	177 20
5RK90GU-AWMU /5GU□RAA	Rating	10.6 1.2	12.3 1.4	17.7 2.0	21 2.4	26 3.0	31 3.6	44 5.0	53 6.0	63 7.2	87 9.9	92 10.5	111 12.6	155 17.6	177 20	177 20	177 20	177 20	177 20	177 20	177 20
	Startup	9.7 1.1	11.5 1.3	15.9 1.8	18.5 2.1	23 2.7	28 3.2	38 4.4	46 5.3	56 6.4	78 8.9	84 9.6	101 11.5	140 15.9	169 19.1	177 20	177 20	177 20	177 20	177 20	177 20

● **AXU Series Speed Control System**

◆ **Hollow Shaft**

All output shafts rotate opposite to the direction of motor shaft rotation.

Unit = Upper values: lb-in/Lower values: N·m

Model	Gear Ratio											
		3.6	6	9	15	18	30	36	60	90	120	180
Motor/Gearhead	Motor Speed r/min											
AXU425A-GN AXU425C-GN AXU425S-GN /4GN□RH	2000	1.59 0.18	2.6 0.3	4.9 0.56	9.7 1.1	12.3 1.4	20 2.3	23 2.7	39 4.5	60 6.8	70 8	70 8
	Startup	1.94 0.22	3.1 0.36	6.0 0.68	10.6 1.2	13.2 1.5	21 2.4	25 2.9	43 4.9	64 7.3	70 8	70 8
AXU540A-GN AXU540C-GN AXU540S-GN /5GN□RH	2000	3.1 0.36	5.3 0.6	10.6 1.2	17.7 2.0	21 2.4	31 3.6	38 4.3	63 7.2	88 10	88 10	88 10
	Startup	3.8 0.43	6.3 0.72	11.5 1.3	19.4 2.2	23 2.6	34 3.9	41 4.7	69 7.8	88 10	88 10	88 10
AXU590A-GU AXU590C-GU AXU590S-GU /5GU□RH	2000	7.1 0.81	12.3 1.4	24 2.8	40 4.6	48 5.5	71 8.1	85 9.7	143 16.2	177 20	177 20	177 20
	Startup	8.5 0.97	14.1 1.6	25 2.9	43 4.9	51 5.8	76 8.7	92 10.5	154 17.5	177 20	177 20	177 20

◆ **Solid Shaft**

All output shafts rotate opposite to the direction of motor shaft rotation.

Unit = Upper values: lb-in/Lower values: N·m

Model	Gear Ratio											
		3.6	6	9	15	18	30	36	60	90	120	180
Motor/Gearhead	Motor Speed r/min											
AXU425A-GN AXU425C-GN AXU425S-GN /4GN□RAA	2000	2.0 0.23	3.3 0.38	4.9 0.56	9.7 1.1	12.3 1.4	20 2.3	23 2.7	39 4.5	60 6.8	70 8	70 8
	Startup	2.3 0.27	3.9 0.45	6.0 0.68	10.6 1.2	13.2 1.5	21 2.4	25 2.9	43 4.9	64 7.3	70 8	70 8

Unit = Upper values: lb-in/Lower values: N·m

Model	Gear Ratio																				
		3	3.6	5	6	7.5	9	12.5	15	18	25	30	36	50	60	75	90	100	120	150	180
Motor/Gearhead	Motor Speed r/min																				
AXU540A-GN AXU540C-GN AXU540S-GN /5GN□RAA	2000	3.6 0.41	4.3 0.49	6.0 0.68	7.2 0.82	8.8 1.0	10.6 1.2	15 1.7	17.7 2.0	21 2.4	26 3.0	31 3.6	38 4.3	53 6.0	63 7.2	79 9.0	88 10	88 10	88 10	88 10	88 10
	Startup	3.8 0.43	4.6 0.52	6.3 0.72	7.6 0.86	9.7 1.1	11.5 1.3	15.9 1.8	19.4 2.2	23 2.6	28 3.2	34 3.9	41 4.7	57 6.5	69 7.8	85 9.7	88 10	88 10	88 10	88 10	88 10
AXU590A-GU AXU590C-GU AXU590S-GU /5GU□RAA	2000	8.1 0.92	9.7 1.1	13.2 1.5	15.9 1.8	20 2.3	24 2.8	33 3.8	40 4.6	48 5.5	68 7.7	71 8.1	85 9.7	119 13.5	143 16.2	177 20	177 20	177 20	177 20	177 20	177 20
	Startup	8.5 0.97	10.6 1.2	14.1 1.6	16.8 1.9	21 2.4	25 2.9	36 4.1	43 4.9	51 5.8	71 8.1	76 8.7	92 10.5	129 14.6	154 17.5	177 20	177 20	177 20	177 20	177 20	177 20

Introduction

Induction Motors

Reversible Motors

Synchronous Motors

Torque Motors

Waterright Motors

Magnetic Brake

Clutch & Brake

Brake Pack

Right-Angle Gearheads

Accessories

Before Using a Standard AC Motor

● US Series Speed Control System

◆ Hollow Shaft Single-Phase 115 VAC 60 Hz

All output shafts rotate opposite to the direction of motor shaft rotation.

Unit = Upper values: lb-in/Lower values: N-m

Model	Gear Ratio											
		Motor Speed r/min		3.6	6	9	15	18	30	36	60	90
US425-401U /4GN□RH	1200	2.5 0.29	4.2 0.48	7.9 0.90	15.9 1.8	19.4 2.2	31 3.6	38 4.3	63 7.2	70 8	70 8	70 8
	90	0.63 0.072	1.06 0.12	2.0 0.23	3.9 0.45	4.7 0.54	7.9 0.90	9.7 1.1	15.9 1.8	23 2.7	31 3.6	47 5.4
	Startup	1.32 0.15	2.2 0.25	4.1 0.47	7.5 0.85	8.8 1.0	15 1.7	17.7 2.0	30 3.4	45 5.1	60 6.8	70 8
US540-401U /5GN□RH	1200	4.1 0.47	6.9 0.78	14.1 1.6	23 2.7	28 3.2	41 4.7	49 5.6	83 9.4	88 10	88 10	88 10
	90	1.15 0.13	1.85 0.21	3.8 0.43	6.2 0.71	7.6 0.86	11.5 1.3	13.2 1.5	22 2.5	33 3.8	44 5.0	67 7.6
	Startup	2.8 0.32	4.7 0.54	8.5 0.97	14.1 1.6	16.8 1.9	25 2.9	30 3.5	51 5.8	76 8.7	88 10	88 10
US560-501U /5GU□RH	1200	7.7 0.88	13.2 1.5	26 3.0	44 5.0	53 6.0	77 8.8	93 10.6	155 17.6	177 20	177 20	177 20
	90	3.1 0.36	5.3 0.60	10.6 1.2	17.7 2.0	21 2.4	31 3.6	38 4.3	63 7.2	95 10.8	106 12	159 18
	Startup	4.5 0.51	7.6 0.86	13.2 1.5	23 2.6	27 3.1	40 4.6	48 5.5	81 9.2	123 13.9	136 15.4	177 20
US590-501U /5GU□RH	1200	11.5 1.3	19.4 2.2	39 4.5	65 7.4	78 8.9	115 13.1	139 15.8	177 20	177 20	177 20	177 20
	90	3.1 0.36	5.3 0.60	10.6 1.2	17.7 2.0	21 2.4	31 3.6	38 4.3	63 7.2	95 10.8	106 12	159 18
	Startup	6.4 0.73	10.6 1.2	19.4 2.2	31 3.6	38 4.4	58 6.6	69 7.9	115 13.1	174 19.7	177 20	177 20

◆ Solid Shaft Single-Phase 115 VAC 60 Hz

All output shafts rotate opposite to the direction of motor shaft rotation.

Unit = Upper values: lb-in/Lower values: N-m

Model	Gear Ratio											
		Motor Speed r/min		3.6	6	9	15	18	30	36	60	90
US425-401U /4GU□RAA	1200	3.1 0.36	5.3 0.60	7.9 0.90	15.9 1.8	19.4 2.2	31 3.6	38 4.3	63 7.2	70 8	70 8	70 8
	90	0.79 0.090	1.32 0.15	2.0 0.23	3.9 0.45	4.7 0.54	7.9 0.90	9.7 1.1	15.9 1.8	23 2.7	31 3.6	47 5.4
	Startup	1.68 0.19	2.8 0.32	4.1 0.47	7.5 0.85	8.8 1.0	15 1.7	17.7 2.0	30 3.4	45 5.1	60 6.8	70 8

Unit = Upper values: lb-in/Lower values: N-m

Model	Gear Ratio																						
		Motor Speed r/min		3	3.6	5	6	7.5	9	12.5	15	18	25	30	36	50	60	75	90	100	120	150	180
US540-401U /5GN□RAA	1200	4.6 0.53	5.6 0.64	7.7 0.88	9.7 1.1	11.5 1.3	14.1 1.6	19.4 2.2	23 2.7	28 3.2	34 3.9	41 4.7	49 5.6	69 7.8	83 9.4	88 10	88 10	88 10	88 10	88 10	88 10	88 10	88 10
	90	1.23 0.14	1.5 0.17	2.1 0.24	2.5 0.29	3.1 0.36	3.8 0.43	5.3 0.6	6.2 0.71	7.6 0.86	9.7 1.1	11.5 1.3	13.2 1.5	18.5 2.1	22 2.5	28 3.2	33 3.8	37 4.2	44 5.0	55 6.3	67 7.6		
	Startup	1.68 0.19	2.0 0.23	2.8 0.32	3.3 0.38	4.1 0.47	5.0 0.57	6.9 0.79	8.4 0.95	9.7 1.1	12.3 1.4	15 1.7	17.7 2.0	24 2.8	30 3.4	38 4.3	45 5.1	50 5.7	60 6.8	75 8.5	88 10		
US560-501U /5GU□RAA	1200	8.8 1.0	10.6 1.2	15 1.7	17.7 2.0	22 2.5	26 3.0	37 4.2	44 5.0	53 6.0	65 7.4	77 8.8	93 10.6	130 14.7	155 17.6	177 20	177 20	177 20	177 20	177 20	177 20	177 20	177 20
	90	3.6 0.41	4.3 0.49	6.0 0.68	7.2 0.82	8.8 1.0	10.6 1.2	15 1.7	17.7 2.0	21 2.4	26 3.0	31 3.6	38 4.3	53 6.0	63 7.2	79 9.0	95 10.8	106 12	127 14.4	159 18	177 20		
	Startup	4.5 0.51	5.4 0.62	7.6 0.86	8.8 1.0	11.5 1.3	13.2 1.5	18.5 2.1	23 2.6	27 3.1	33 3.8	40 4.6	48 5.5	68 7.7	81 9.2	101 11.5	123 13.9	136 15.4	163 18.5	177 20	177 20	177 20	
US590-501U /5GU□RAA	1200	13.2 1.5	15.9 1.8	22 2.5	26 3.0	32 3.7	39 4.5	54 6.2	65 7.4	78 8.9	97 11	115 13.1	139 15.8	177 20	177 20	177 20	177 20	177 20	177 20	177 20	177 20	177 20	
	90	3.6 0.41	4.3 0.49	6.0 0.68	7.2 0.82	8.8 1.0	10.6 1.2	15 1.7	17.7 2.0	21 2.4	26 3.0	31 3.6	38 4.3	53 6.0	63 7.2	79 9.0	95 10.8	106 12	127 14.4	159 18	177 20		
	Startup	6.4 0.73	7.6 0.87	10.6 1.2	13.2 1.5	15.9 1.8	19.4 2.2	26 3.0	31 3.6	38 4.4	48 5.5	58 6.6	69 7.9	96 10.9	115 13.1	145 16.4	174 19.7	177 20	177 20	177 20	177 20	177 20	

● **ES Series Speed Control Systems Induction Motors**

◆ **Hollow Shaft Single-Phase 115 VAC 60 Hz**

Applicable Speed Controllers: ES01

Unit = Upper values: lb-in/Lower values: N·m

Model	Gear Ratio											
		3.6	6	9	15	18	30	36	60	90	120	180
Motor/Gearhead	Motor Speed r/min											
41K25RGN-AWU /4GN□RH	1200	2.3 0.27	3.8 0.44	7.3 0.83	15 1.7	17.7 2.0	29 3.3	35 4.0	59 6.7	70 8	70 8	70 8
	90	0.63 0.072	1.06 0.12	2.0 0.23	3.9 0.45	4.7 0.54	7.9 0.9	9.7 1.1	15.9 1.8	23 2.7	31 3.6	47 5.4
	Startup	1.5 0.17	2.5 0.29	4.7 0.54	8.5 0.97	10.6 1.2	16.8 1.9	20 2.3	34 3.9	51 5.8	69 7.8	70 8
51K40RGN-AWU /5GN□RH	1200	3.6 0.41	6.0 0.68	12.3 1.4	20 2.3	2.4 2.8	36 4.1	43 4.9	71 8.1	88 10	88 10	88 10
	90	1.06 0.12	1.77 0.2	3.6 0.41	6.0 0.68	7.2 0.82	10.6 1.2	12.3 1.4	21 2.4	31 3.6	42 4.8	63 7.2
	Startup	3.1 0.36	5.3 0.6	9.7 1.1	15.9 1.8	19.4 2.2	28 3.2	34 3.9	57 6.5	85 9.7	88 10	88 10
51K60RGU-AWU /5GU□RH	1200	7.7 0.88	13.2 1.5	26 3.0	44 5.0	53 6.0	77 8.8	93 10.6	155 17.6	177 20	177 20	177 20
	90	3.3 0.38	5.5 0.63	11.5 1.3	18.5 2.1	23 2.6	33 3.8	39 4.5	67 7.6	100 11.3	111 12.6	167 18.9
	Startup	5.1 0.58	8.4 0.96	15 1.7	25 2.9	30 3.5	46 5.2	54 6.2	92 10.4	138 15.6	153 17.3	177 20

◆ **Solid Shaft Single-Phase 115 VAC 60 Hz**

Applicable Speed Controllers: ES01

Unit = Upper values: lb-in/Lower values: N·m

Model	Gear Ratio											
		3.6	6	9	15	18	30	36	60	90	120	180
Motor/Gearhead	Motor Speed r/min											
41K25RGN-AWU /4GN□RAA	1200	2.9 0.33	4.9 0.56	7.3 0.83	15 1.7	17.7 2	29 3.3	35 4	59 6.7	70 8	70 8	70 8
	90	0.79 0.09	1.32 0.15	2.0 0.23	3.9 0.45	4.7 0.54	7.9 0.9	9.7 1.1	15.9 1.8	23 2.7	31 3.6	47 5.4
	Startup	1.94 0.22	3.1 0.36	4.7 0.54	8.5 0.97	10.6 1.2	16.8 1.9	20 2.3	34 3.9	51 5.8	69 7.8	70 8

Unit = Upper values: lb-in/Lower values: N·m

Model	Gear Ratio																				
		3	3.6	5	6	7.5	9	12.5	15	18	25	30	36	50	60	75	90	100	120	150	180
Motor/Gearhead	Motor Speed r/min																				
51K40RGN-AWU /5GN□RAA	1200	4.0 0.46	4.8 0.55	6.8 0.77	8.1 0.92	9.7 1.1	12.3 1.4	16.8 1.9	20 2.3	24 2.8	30 3.4	36 4.1	43 4.9	60 6.8	71 8.1	88 10	88 10	88 10	88 10	88 10	88 10
	90	1.23 0.14	1.41 0.16	2.0 0.23	2.3 0.27	3.0 0.34	3.6 0.41	5.0 0.57	6.0 0.68	7.2 0.82	8.8 1.0	10.6 1.2	12.3 1.4	17.7 2.0	21 2.4	26 3.0	31 3.6	35 4.0	42 4.8	53 6.0	63 7.2
	Startup	3.1 0.36	3.8 0.43	5.3 0.6	6.3 0.72	7.9 0.9	9.7 1.1	13.2 1.5	15.9 1.8	19.4 2.2	23 2.7	28 3.2	34 3.9	47 5.4	57 6.5	71 8.1	85 9.7	88 10	88 10	88 10	88 10
51K60RGU-AWU /5GU□RAA	1200	8.8 1.0	10.6 1.2	15 1.7	17.7 2.0	22 2.5	26 3.0	37 4.2	44 5.0	53 6.0	73 8.3	77 8.8	93 10.6	130 14.7	155 17.6	177 20	177 20	177 20	177 20	177 20	177 20
	90	3.8 0.43	4.5 0.51	6.2 0.71	7.6 0.86	9.7 1.1	11.5 1.3	15.9 1.8	18.5 2.1	23 2.6	31 3.6	33 3.8	39 4.5	55 6.3	67 7.6	84 9.5	100 11.3	111 12.6	111 12.6	139 15.8	167 18.9
	Startup	5.1 0.58	6.1 0.69	8.4 0.96	10.6 1.2	12.3 1.4	15 1.7	21 2.4	25 2.9	30 3.5	42 4.8	46 5.2	54 6.2	76 8.6	92 10.4	115 13	138 15.6	153 17.3	153 17.3	177 20	177 20

All output shafts rotate opposite to the direction of motor shaft rotation.

● **ES Series Speed Control Systems Reversible Motors**

◆ **Hollow Shaft Single-Phase 115 VAC 60 Hz**

Applicable Speed Controllers: ES01

Unit = Upper values: lb-in/Lower values: N-m

Model	Gear Ratio											
Motor/Gearhead	Motor Speed r/min	3.6	6	9	15	18	30	36	60	90	120	180
4RK25RGN-AWU /4GN□RH	1200	2.6 0.3	4.3 0.49	8.1 0.92	15.9 1.8	19.4 2.2	32 3.7	38 4.4	65 7.4	70 8	70 8	70 8
	90	1.41 0.16	2.3 0.26	4.4 0.5	8.7 0.99	10.6 1.2	17.7 2.0	21 2.4	35 4.0	52 5.9	69 7.9	70 8
	Startup	1.77 0.2	3.0 0.34	5.5 0.63	9.7 1.1	12.3 1.4	20 2.3	23 2.7	39 4.5	60 6.8	70 8	70 8
5RK40RGN-AWU /5GN□RH	1200	5.1 0.58	8.4 0.96	17.7 2.0	29 3.3	34 3.9	51 5.8	61 6.9	88 10	88 10	88 10	88 10
	90	2.4 0.28	4.1 0.47	8.4 0.95	14.1 1.6	16.8 1.9	24 2.8	29 3.3	49 5.6	74 8.4	88 10	88 10
	Startup	4.1 0.47	6.9 0.78	12.3 1.4	20 2.3	24 2.8	37 4.2	45 5.1	74 8.4	88 10	88 10	88 10
5RK60RGU-AWU /5GU□RH	1200	7.7 0.88	13.2 1.5	26 3.0	44 5.0	53 6.0	77 8.8	93 10.6	155 17.6	177 20	177 20	177 20
	90	4.3 0.49	7.1 0.81	15 1.7	24 2.8	29 3.3	43 4.9	51 5.8	85 9.7	129 14.6	143 16.2	177 20
	Startup	6.0 0.68	9.7 1.1	18.5 2.1	30 3.4	36 4.1	54 6.2	65 7.4	108 12.3	163 18.5	177 20	177 20

◆ **Solid Shaft Single-Phase 115 VAC 60 Hz**

Applicable Speed Controllers: ES01

Unit = Upper values: lb-in/Lower values: N-m

Model	Gear Ratio											
Motor/Gearhead	Motor Speed r/min	3.6	6	9	15	18	30	36	60	90	120	180
4RK25RGN-AWU /4GN□RAA	1200	3.2 0.37	5.4 0.62	8.1 0.92	15.9 1.8	19.4 2.2	32 3.7	38 4.4	65 7.4	70 8	70 8	70 8
	90	1.77 0.2	2.9 0.33	4.4 0.5	8.7 0.99	10.6 1.2	17.7 2.0	21 2.4	35 4.0	52 5.9	69 7.9	70 8
	Startup	2.2 0.25	3.7 0.42	5.5 0.63	9.7 1.1	12.3 1.4	20 2.3	23 2.7	39 4.5	60 6.8	70 8	70 8

Unit = Upper values: lb-in/Lower values: N-m

Model	Gear Ratio																					
Motor/Gearhead	Motor Speed r/min	3	3.6	5	6	7.5	9	12.5	15	18	25	30	36	50	60	75	90	100	120	150	180	
5RK40RGN-AWU /5GN□RAA	1200	5.7 0.65	6.9 0.78	9.7 1.1	11.5 1.3	14.1 1.6	17.7 2.0	23 2.7	29 3.3	34 3.9	42 4.8	51 5.8	61 6.9	84 9.6	88 10	88 10	88 10	88 10	88 10	88 10	88 10	
	90	2.8 0.32	3.3 0.38	4.6 0.53	5.5 0.63	6.9 0.79	8.4 0.95	11.5 1.3	14.1 1.6	16.8 1.9	20 2.3	24 2.8	29 3.3	41 4.7	49 5.6	61 7.0	74 8.4	82 9.3	88 10	88 10	88 10	88 10
	Startup	4.1 0.47	4.9 0.56	6.9 0.78	8.3 0.94	10.6 1.2	12.3 1.4	17.7 2.0	20 2.3	24 2.8	30 3.5	37 4.2	45 5.1	61 7.0	74 8.4	88 10	88 10	88 10	88 10	88 10	88 10	88 10
5RK60RGU-AWU /5GU□RAA	1200	8.8 1.0	10.6 1.2	15 1.7	17.7 2.0	22 2.5	26 3.0	37 4.2	44 5.0	53 6.0	73 8.3	77 8.8	93 10.6	130 14.7	155 17.6	177 20	177 20	177 20	177 20	177 20	177 20	177 20
	90	4.8 0.55	5.8 0.66	8.1 0.92	9.7 1.1	12.3 1.4	15 1.7	20 2.3	24 2.8	29 3.3	40 4.6	43 4.9	51 5.8	71 8.1	85 9.7	107 12.2	129 14.6	143 16.2	143 16.2	177 20	177 20	177 20
	Startup	6.0 0.68	7.2 0.82	9.7 1.1	12.3 1.4	15 1.7	18.5 2.1	25 2.9	30 3.4	36 4.1	50 5.7	54 6.2	65 7.4	91 10.3	108 12.3	136 15.4	163 18.5	177 20	177 20	177 20	177 20	177 20

All output shafts rotate opposite to the direction of motor shaft rotation.