



Introduction

Induction Motors

Reversible Motors

Synchronous Motors

Torque Motors

Waterlight Motors

Magnetic Brake

Clutch & Brake

Brake Pack

Right-Angle Gearheads

Accessories

Before Using a Standard AC Motor

# Induction Motors

## Additional Information

Technical Reference	F-1
General Information	G-1

1 W	A-18
6 W	A-20
15 W	A-24
25 W	A-28
40 W	A-34
60 W	A-40
90 W	A-47
200 W	A-54
40~90 W (2-Pole)	A-65

# Induction Motors



World **K** Series  
(Lead Wire Type)



World **K** Series  
(Conduit Box Type)



**V** Series  
(Terminal Box Type)



**BH** Series  
(Terminal Box Type)

\* Gearheads shown in the photograph are sold separately. The **V** Series and the **BH** Series are Combination Type. (Pre-assembled Gearmotor)

## Features

### ● Optimal for Uni-Directional Continuous Operation

Induction Motors are optimal for uni-directional continuous operation such as a conveyor system.

### ● Wide Variety of Products

World **K** Series, **K** Series, **V** Series and **BH** Series motors are available. For the connection with the power supply, you can select from lead wire type, terminal box type and conduit box type.

### ● Conform to Safety Standards and Global Power Supply Voltages

Conforms to UL/CSA/EN standards and the CE Marking is being used in accordance with the low voltage directive. Also, our wide range of products includes those that meet the power supply voltages of North America, Asia and major countries in Europe.

\* Some models are not certified by EN standards.

### Combination Type (Pre-assembled Gearmotors) (**V** Series, **BH** Series)

The Combination type (pre-assembled gearmotors) come with the motor and its dedicated gearhead already assembled. This simplifies installation in equipment. Motors and gearheads are also available separately so they can be on hand to make changes or repair.

## Safety Standards and CE Marking

### ● World **K** Series, **V** Series, **K** Series (Conduit Box Type)

Standards	Certification Body	Standards File No.	CE Marking
UL1004 UL2111	UL	E64199 (6 W)	Low Voltage Directives
CSA C22.2 No.100 CSA C22.2 No.77		E64197 (15 W~90 W)	
EN60950 *1	VDE	114919ÜG (6 W)	
	DEMKO	6751ÜG (15 W~90 W)*3	
EN60034-1 EN60034-5 IEC60034-11 *2	Conform to EN/IEC Standards		

\*1 Excluding conduit box types.

\*2 15 W~90 W types.

\*3 Except **V** Series 90 W.

● When the motor is approved under various standards, the model name on the nameplate is the approved model name.

● **Details of Safety Standard** → Page G-2

● **List of Safety Standard Approved Products** → Page G-10~G-13

## ● K Series

Standards	Certification Body	Standards File No.	CE Marking
UL1004 UL519	UL	E64199	Low Voltage Directives
CSA C22.2 No.100*1 CSA C22.2 No.77*1	CSA	LR47296	
EN60950*2	VDE	5876ÜG	

\*1 Only 1 W type.

\*2 Except **4IK40A-BA**.

● **Details of Safety Standard** →Page G-2

## ● BH Series

Standards	Certification Body	Standards File No.	CE Marking
UL1004 UL2111	UL	E64197	Low Voltage Directives
CSA C22.2 No.100 CSA C22.2 No.77			
EN60950 EN60034-1 EN60034-5 IEC60034-11	Conform to EN/IEC Standards		

## ■ System Configuration

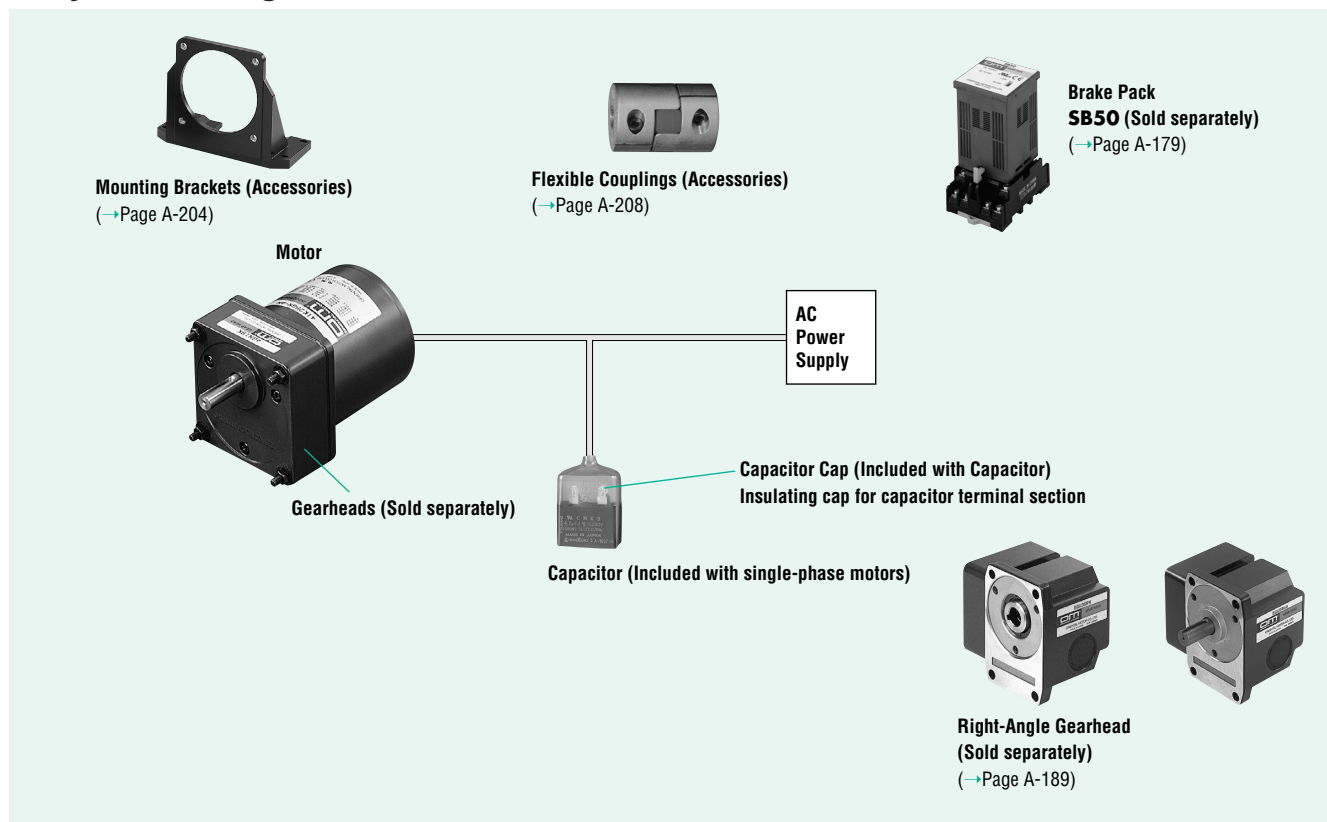

The system configuration shown is an example. Other configurations are available.

## Product Number Codes

### World K Series

**5 I K 40 GN - A W T U**

**5**: Motor Frame Size  
**I**: Motor Type  
**K**: Motor Series  
**40**: Output Power (Example)  
**GN**: Motor Shaft Type  
**A**: Voltage and No. of Poles  
**W**: Included Capacitor  
**T**: Terminal Box Type  
**U**: Included Capacitor

**Output Power**  
 (Example)  
**40**: 40 W

**Motor Series**  
**K**: K series

**Motor Type**  
**I**: Induction motor

**Motor Frame Size**  
**2**: 2.36 in. sq. (60 mm sq.)  
**3**: 2.76 in. sq. (70 mm sq.)  
**4**: 3.15 in. sq. (80 mm sq.)  
**5**: 3.54 in. sq. (90 mm sq.)

**Voltage and No. of Poles**  
**AW**: Single-Phase 100/110/115 VAC, 4 Poles  
**CW**: Single-Phase 200/220/230 VAC, 4 Poles  
**SW**: Three-Phase 200/220/230 VAC, 4 Poles

**Motor Shaft Type**  
**GN**: Pinion shaft (for use with **GN**-type gearhead)  
**GU**: Pinion shaft (for use with **GU**-type gearhead)  
**A**: Round shaft

**Note:**  
 • The "U" and "E" at the end of the model number indicate that the unit includes a capacitor. These two letters are not listed on the motor nameplate.

### K Series

#### 1 W Type, 2-Pole Type

**5 I K 90 A - B F U L**

**5**: Motor Frame Size  
**I**: Motor Type  
**K**: Motor Series  
**90**: Output Power (Example)  
**A**: Voltage and No. of Poles  
**B**: Motor Shaft Type  
**F**: Motor Shaft Type  
**U**: Motor Shaft Type  
**L**: Motor Shaft Type

**Output Power**  
 (Example)  
**90**: 90 W

**Motor Series**  
**K**: K series

**Motor Type**  
**I**: Induction motor

**Motor Frame Size**  
**0**: 1.65 in. sq. (42 mm sq.)  
**4**: 3.15 in. sq. (80 mm sq.)  
**5**: 3.54 in. sq. (90 mm sq.)

**Voltage and No. of Poles**  
**A**: Single-Phase 115 VAC, 4 Poles  
**B**: Single-Phase 115 VAC, 2 Poles

**Motor Shaft Type**  
**GN**: Pinion shaft (for use with **GN**-type gearhead)  
**A**: Round shaft

**UL**: UL recognized and CSA\*, VDE certified  
 \* Only 1 W Type

**F**: With built-in cooling fan

\* If the product code number ends with "A", this indicates an inch size shaft motor.

### V Series

**V H I 5 40 A T - 300 U**

**V**: Motor Series  
**H**: High Power  
**I**: Motor Type  
**5**: Motor Frame Size  
**40**: Output Power (Example)  
**A**: Voltage and No. of Poles  
**T**: Motor Shaft Type  
**300**: Gear Ratio (Example)  
**U**: Included Capacitor

**Note:**  
 • The "U" and "E" at the end of the model number indicate that the unit includes a capacitor. These two letters are not listed on the motor nameplate.

### World K Series and K Series Gearheads

**5 GN 50 KA**

**5**: Gearhead Frame Size  
**GN**: Gearhead Type  
**50**: Gear Ratio (Example)  
**KA**: Type of Bearings and Shaft Type

**Gearhead Type**  
**GN**: GN type (for use with **GN**-type pinion shaft motor)  
**GU**: GU type (for use with **GU**-type pinion shaft motor)

**Gearhead Frame Size**  
**0**: 1.65 in. sq. (42 mm sq.)  
**2**: 2.36 in. sq. (60 mm sq.)  
**3**: 2.76 in. sq. (70 mm sq.)  
**4**: 3.15 in. sq. (80 mm sq.)  
**5**: 3.54 in. sq. (90 mm sq.)

**Type of Bearings and Shaft Type**  
**KA**: Ball Bearing Type (inch-size)  
**RAA**: Right Angle Solid Shaft Type (inch size)  
**RH**: Right Angle Hollow Shaft Type

**Gear Ratio**  
 (Example)  
**50**: Gear ratio of 50:1  
**10X** denotes the decimal gearhead of gear ratio 10:1

#### Conduit Box Type

**5 I K 40 GN - F C H**

**5**: Motor Frame Size  
**I**: Motor Type  
**K**: Motor Series  
**40**: Output Power (Example)  
**GN**: Motor Shaft Type  
**F**: Voltage  
**C**: Motor Shaft Type  
**H**: Conduit Box Type

**Output Power**  
 (Example)  
**40**: 40 W

**Motor Series**  
**K**: K series

**Motor Type**  
**I**: Induction motor

**Motor Frame Size**  
**4**: 3.15 in. sq. (80 mm sq.)  
**5**: 3.54 in. sq. (90 mm sq.)

**Voltage**  
**F**: Single-phase 110/115 VAC  
**E**: Single-phase 220/230 VAC  
**S**: Three-phase 200/220/230 VAC

**Motor Shaft Type**  
**GN**: Pinion shaft (for use with **GN**-type gearhead)  
**GU**: Pinion shaft (for use with **GU**-type gearhead)  
**A, AA**: Round shaft

### BH Series

**BH I 6 2 FT - 5 RH**

**BH**: Motor Series  
**I**: Motor Type  
**6**: Motor Frame Size  
**2**: Output Power  
**FT**: Motor Shaft Type  
**5**: Gear Ratio  
**RH**: Type of Bearings and Shaft Type

**Note:**  
 • The "U" and "E" at the end of the model number indicate that the unit includes a capacitor. These two letters are not listed on the motor nameplate.

## General Specifications

### World K Series, V Series, K Series (Conduit Box Type)

Item	Specifications
Insulation Resistance	100 MΩ or more when 500 VDC is applied between the windings and the frame after rated motor operation under normal ambient temperature and humidity.
Dielectric Strength	Sufficient to withstand 1.5 kV at 50 Hz and 60 Hz applied between the windings and the frame for 1 minute after rated motor operation under normal ambient temperature and humidity.
Temperature Rise	Temperature rise of windings are 144°F (80°C) or less measured by the resistance change method after rated motor operation with connecting a gearhead or equivalent heat radiation plate*. [Three-Phase 6 W type : 126°F (70°C)]
Insulation Class	Class B (266°F [130°C])
Overheat Protection	6 W type have impedance protection. All others have built-in thermal protector (Automatic return type) Operating temperature, open : 266°F±9°F (130°C±5°C) close: 179.6°F±27°F (82°C±15°C)
Ambient Temperature Range	14°F~104°F (-10°C~+40°C) [Three-phase 200 VAC: 14°F~122°F (-10°C~+50°C)] (nonfreezing)
Ambient Humidity	85% maximum (noncondensing)
Degree of Protection	Lead wire type (World <b>K</b> Series, <b>V</b> Series) : IP 20 Terminal box type (World <b>K</b> Series, <b>V</b> Series) : 25 W, 40 W IP 54 60 W, 90 W IP 44

### \* Heat radiation plate (material: Aluminum)

Type (output)	Size: in. (mm)	Thickness: in. (mm)
<b>2IK</b> Type (6 W)	4.53×4.53 (115×115)	0.20 (5)
<b>3IK</b> Type (15 W)	4.92×4.92 (125×125)	
<b>4IK</b> Type (25 W)	5.31×5.31 (135×135)	
<b>5IK40</b> Type (40 W)	6.50×6.50 (165×165)	
<b>5IK60</b> Type (60 W)	7.87×7.87 (200×200)	
<b>5IK90</b> Type (90 W)	7.87×7.87 (200×200)	

### K Series

Item	Specifications
Insulation Resistance	100 MΩ or more when 500 VDC is applied between the windings and the frame after rated motor operation under normal ambient temperature and humidity.
Dielectric Strength	Sufficient to withstand 1.5 kV at 60 Hz applied between the windings and the frame for 1 minute after rated motor operation under normal ambient temperature and humidity.
Temperature Rise	Temperature rise of windings are 135°F (75°C) or less measured by the resistance change method after rated motor operation.
Insulation Class	Class A (221°F [105°C]) ( <b>0IK1GN-AUL</b> , <b>0IK1A-AUL</b> , <b>5IK90A-BFUL</b> : UL/CSA Standards...Class A, EN Standards...Class E)
Overheat Protection	1 W type is impedance protected. All others have built-in thermal protector (Automatic return type) Operating temperature, open: 248°F±9°F (120°C±5°C) close: 170.6°F±27°F (77°C±15°C)
Ambient Temperature Range	14°F~104°F (-10°C~+40°C) (nonfreezing)
Ambient Humidity	85% maximum (noncondensing)
Degree of Protection	IP20

### BH Series

Item	Specifications
Insulation Resistance	100 MΩ or more when 500 VDC is applied between the windings and the frame after rated motor operation under normal ambient temperature and humidity.
Dielectric Strength	Sufficient to withstand 1.5 kV at 50 Hz and 60 Hz applied between the windings and the frame for 1 minute after rated motor operation under normal ambient temperature and humidity.
Temperature Rise	Temperature rise of windings are 144°F (80°C) or less measured by the resistance change method after rated motor operation with connecting a gearhead or equivalent heat radiation plate*. [Three-Phase type: 126°F (70°C)]
Insulation Class	Class B (266°F [130°C])
Overheat Protection	Built-in thermal protector (Automatic return type) Operating temperature, open : 302°F±9°F (150°C±5°C) close : 204.8°F±27°F (96°C±15°C)
Ambient Temperature Range	14°F~104°F (-10°C~+40°C) [Three-Phase 200 VAC: 14°F~122°F (-10°C~+50°C)] (nonfreezing)
Ambient Humidity	85% maximum (noncondensing)
Degree of Protection	Cable Type: IP40 Terminal Box Type: IP54

\* Heat radiation plate: 9.06 inch×9.06 inch (230 mm×230 mm), 0.20 inch (5 mm) thickness (Material: Aluminum)

## Induction Motors

## 1 W (1/750 HP)

Frame Size: □ 1.65 in. (□ 42 mm)

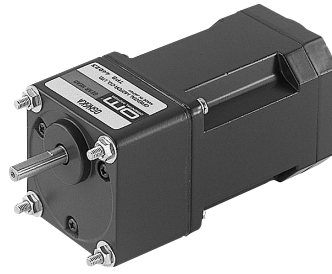

(Gearhead Sold Separately)

## Specifications — Continuous Rating



Model	Output Power		Voltage	Frequency	Current	Starting Torque		Rated Torque		Rated Speed	Capacitor	
	HP	W	VAC	Hz	A	oz-in	mN·m	oz-in	mN·m	r/min	μF	
Upper Model Name: Pinion Shaft Type Lower Model Name ( ): Round Shaft Type <b>○ ZP OIK1GN-AUL</b> <b>(OIK1A-AUL)</b>	1/750	1	Single-Phase	115	60	0.08	1.13	8	1.13	8	1200	1.0

○ ZP Impedance protected.

● Details of Safety Standard → Page G-2

## Gearhead (Sold Separately)

### ● Parallel Shaft

Gearhead Model	Gear Ratio
<b>OGN□KA</b>	<b>3~180</b>

● Enter the gear ratio in the box (□) within the model name.

## Gearmotor — Torque Table

Unit = Upper values: lb-in / Lower values: N-m

Model	Speed r/min	600	500	360	300	240	200	144	120	100	72	60	50	36	30	24	20	18	15	12	10
	Gear Ratio	3	3.6	5	6	7.5	9	12.5	15	18	25	30	36	50	60	75	90	100	120	150	180
<b>○ OIK1GN-AUL / OGN□KA</b>	0.168	0.2	0.28	0.34	0.43	0.51	0.64	0.77	0.97	1.15	1.41	1.68	2.3	2.8	3	3.7	4.1	5	6.2	7.5	
	0.019	0.023	0.032	0.039	0.049	0.058	0.073	0.088	0.11	0.13	0.16	0.19	0.26	0.32	0.35	0.42	0.47	0.57	0.71	0.85	

● Gearheads are sold separately. Decimal gearheads are not available for 1W motors.

● Enter the gear ratio in the box (□) within the model name. A colored background indicates gear shaft rotation in the same direction as the motor shaft; a white background indicates rotation in the opposite direction.

● The speed is calculated by dividing the motor's synchronous speed (60 Hz: 1800 r/min) by the gear ratio. The actual speed is 2~33% less than the displayed value, depending on the size of the load.

## Permissible Overhung Load and Permissible Thrust Load

Motor (Round shaft type) → Page A-11

Gearhead → Page A-11

## Permissible Load Inertia J for Gearhead

→ Page A-12

## ■ Dimensions Scale 1/4, Unit = inch (mm)

Mounting screws are included with gearheads. Dimensions for screws → A-223

### ◆ Lead Wire Type

#### Motor OIK1GN-AUL

Weight: 0.66 lb. (0.3 kg)

#### Gearhead 0GN□KA

Weight: 0.44 lb. (0.2 kg)

DXF A001U (0GN3KA ~ 180KA)

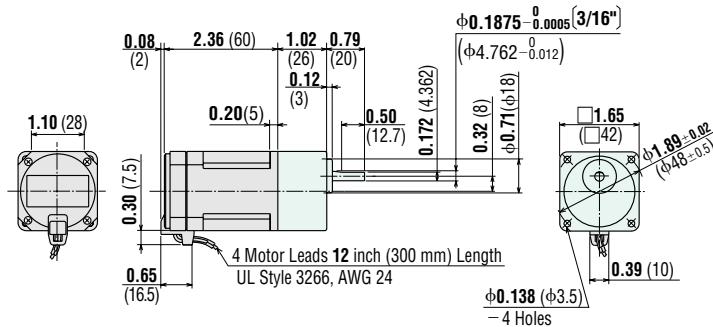

#### Round Shaft Type OIK1A-AUL

Weight: 0.66 lb. (0.3 kg)

DXF A372

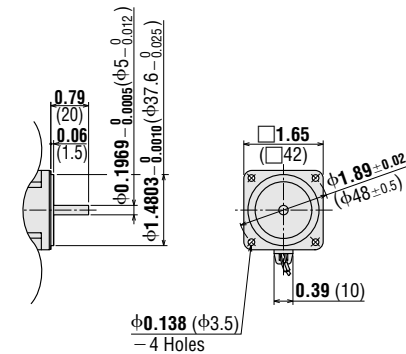

### ● Capacitor (included with the motor)

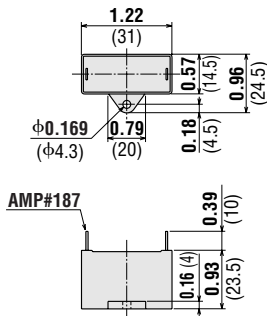

Motor Model	Capacitor Model	Weight oz. (g)
OIK1GN-AUL	CH10UL	0.6 (17)
OIK1A-AUL		

- If you need to order a capacitor without a motor, add "-C" to the capacitor model name shown. A capacitor cap is included with a capacitor.

## ■ Connection Diagrams

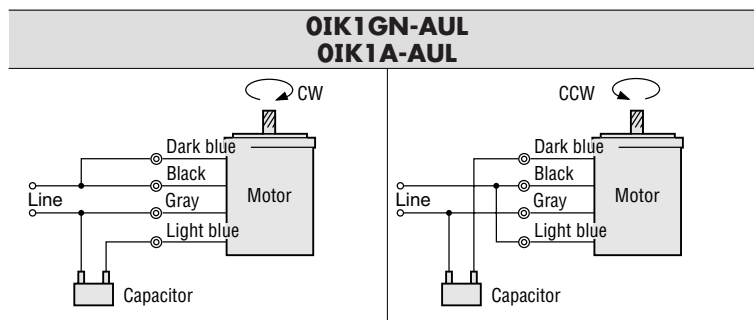

- The direction of motor rotation is as viewed from the shaft end of the motor.
- CW represents the clockwise direction, while CCW represents the counterclockwise direction.
- Connection diagrams are also valid for the equivalent round shaft type.
- **How to connect a capacitor** → Page A-225

#### Note:

- Change the direction of motor rotation only after bringing the motor to a stop. If an attempt is made to change the direction of rotation while the motor is rotating, the motor may ignore reversing command or change its direction of rotation after some delay.

## Induction Motors

## 6 W (1/125 HP)

Frame Size: □ 2.36 in. (□ 60 mm)

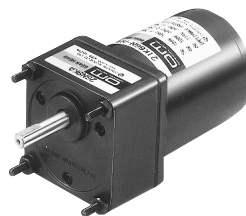
World **K** Series  
(Gearhead Sold Separately)**V** Series/Combination Type  
(Pre-assembled Gearmotor)

## Specifications — Continuous Rating

### World K Series (General Purpose)



Model		Output Power	Voltage	Frequency	Current	Starting Torque	Rated Torque	Rated Speed	Capacitor			
Upper Model Name: Pinion Shaft Type Lower Model Name( ): Round Shaft Type	Terminal Box Type											
Lead Wire Type Dimension ①	Terminal Box Type Dimension ②	HP	W	VAC	Hz	A	oz-in	mN·m	oz-in	mN·m	r/min	μF
Ⓜ <b>2IK6GN-AWU</b> ( <b>2IK6A-AWU</b> )	<b>2IK6GN-AWTU</b> ( <b>2IK6A-AWTU</b> )	1/125	6	Single-Phase 110	60	0.2	5.6	40	5.8	41	1450	2.5
				Single-Phase 115	60							
Ⓜ <b>2IK6GN-CWE</b> ( <b>2IK6A-CWE</b> )	<b>2IK6GN-CWTE</b> ( <b>2IK6A-CWTE</b> )	1/125	6	Single-Phase 220	50	0.11	5.3	38	6.9	49	1200	0.6
				Single-Phase 220	60							
				Single-Phase 230	50							
				Single-Phase 230	60							
Ⓜ <b>2IK6GN-SW</b> ( <b>2IK6A-SW</b> )	<b>2IK6GN-SWT</b> ( <b>2IK6A-SWT</b> )	1/125	6	Three-Phase 200	50	0.09	6.9	49	6.9	49	1200	—
				Three-Phase 200	60							
				Three-Phase 220	60							
				Three-Phase 230	60							

Ⓜ Impedance protected.

- The "U" and "E" at the end of the model name indicate that the unit includes a capacitor. These two letters are not listed on the motor nameplate.

- When the motor is approved under various safety standards, the model name on the nameplate is the approved model name. →Page G-10

- Details of Safety Standard →Page G-2

### V Series (Quiet Operation, High Strength, Long Life)



Model		Output Power	Voltage	Frequency	Current	Starting Torque	Rated Torque	Rated Speed	Capacitor			
Combination Type	Terminal Box Type											
Lead Wire Type Dimension ③	Terminal Box Type	HP	W	VAC	Hz	A	oz-in	mN·m	oz-in	mN·m	r/min	μF
Ⓜ <b>VHI206A-□U</b>	—	1/125	6	Single-Phase 110	60	0.2	5.6	40	5.8	41	1450	2.5
				Single-Phase 115	60							
Ⓜ <b>VHI206C-□E</b>	—	1/125	6	Single-Phase 220	50	0.11	5.3	38	6.9	49	1200	0.6
				Single-Phase 220	60							
				Single-Phase 230	50							
				Single-Phase 230	60							

Ⓜ Impedance protected.

- The "U" and "E" at the end of the model name indicate that the unit includes a capacitor. These two letters are not listed on the motor nameplate.

- When the motor is approved under various safety standards, the model name on the nameplate is the approved model name. →Page G-11

- Details of Safety Standard →Page G-2

- Models above are provided as combination type with motor and gearhead pre-assembled.

- Enter gear ratio in the box (□) within the model name.

- The values in the table are for the motor only.

## Gearhead for World K Series (Sold Separately)

### Parallel Shaft

Gearhead Model	Gear Ratio
<b>2GN□KA</b>	<b>3~180</b>
<b>2GN10XK</b> (Decimal Gearhead)	

- Enter the gear ratio in the box (□) within the model name.



## ■ Gearmotor — Torque Table

### ● World K Series (General Purpose)

The maximum permissible torque with a decimal gearhead with a gear ratio of 10:1 is 26 lb-in (3 N-m).

#### ◆ Single-Phase 115/230 VAC 60 Hz, Three-Phase 230 VAC 60 Hz

Unit = Upper values: lb-in/Lower values: N-m

Model	Speed r/min	600	500	360	300	240	200	144	120	100	72	60	50	36	30	24	20	18	15	12	10
	Gear Ratio	<b>3</b>	<b>3.6</b>	<b>5</b>	<b>6</b>	<b>7.5</b>	<b>9</b>	<b>12.5</b>	<b>15</b>	<b>18</b>	<b>25</b>	<b>30</b>	<b>36</b>	<b>50</b>	<b>60</b>	<b>75</b>	<b>90</b>	<b>100</b>	<b>120</b>	<b>150</b>	<b>180</b>
<b>2IK6GN-AWU</b> <b>2IK6GN-AWTU</b> <b>2IK6GN-CWE</b> <b>2IK6GN-CWTE</b> <b>2IK6GN-SW</b> <b>2IK6GN-SWT</b>	<b>2GN□KA</b>	0.88	1.06	1.5	1.77	2.2	2.6	3.7	4.4	5.3	6.6	7.9	9.7	12.3	14.1	17.7	21	23	26	26	26
		0.10	0.12	0.17	0.20	0.25	0.30	0.42	0.50	0.60	0.75	0.90	1.1	1.4	1.6	2.0	2.4	2.7	3	3	3

#### ◆ Single-Phase 230 VAC 50 Hz

Unit = Upper values: lb-in/Lower values: N-m

Model	Speed r/min	500	416	300	250	200	166	120	100	83	60	50	41	30	25	20	16	15	12.5	10	8.3
	Gear Ratio	<b>3</b>	<b>3.6</b>	<b>5</b>	<b>6</b>	<b>7.5</b>	<b>9</b>	<b>12.5</b>	<b>15</b>	<b>18</b>	<b>25</b>	<b>30</b>	<b>36</b>	<b>50</b>	<b>60</b>	<b>75</b>	<b>90</b>	<b>100</b>	<b>120</b>	<b>150</b>	<b>180</b>
<b>2IK6GN-CWE</b> <b>2IK6GN-CWTE</b>	<b>2GN□KA</b>	1.06	1.23	1.77	2.1	2.6	3.1	4.4	5.3	6.2	7.8	9.7	11.5	14.1	16.8	21	25	26	26	26	26
		0.12	0.14	0.20	0.24	0.30	0.36	0.50	0.60	0.71	0.89	1.1	1.3	1.6	1.9	2.4	2.9	3	3	3	3

### ● V Series (Quiet Operation, High Strength, Long Life)

#### ◆ Single-Phase 115/230 VAC 60 Hz

Unit = Upper values: lb-in/Lower values: N-m

Model	Speed r/min	360	300	200	120	100	60	50	30	20	15	10	6	5
	Gear Ratio	<b>5</b>	<b>6</b>	<b>9</b>	<b>15</b>	<b>18</b>	<b>30</b>	<b>36</b>	<b>60</b>	<b>90</b>	<b>120</b>	<b>180</b>	<b>300</b>	<b>360</b>
<b>VHI206A-□U</b> <b>VHI206C-□E</b>		1.59	1.94	2.9	4.8	5.8	9.7	11.5	18.5	28	37	53	53	53
		0.18	0.22	0.33	0.55	0.66	1.1	1.3	2.1	3.2	4.2	6	6	6

#### ◆ Single-Phase 230 VAC 50 Hz

Unit = Upper values: lb-in/Lower values: N-m

Model	Speed r/min	300	250	166	100	83	50	41	25	16	12.5	8.3	5	4.2
	Gear Ratio	<b>5</b>	<b>6</b>	<b>9</b>	<b>15</b>	<b>18</b>	<b>30</b>	<b>36</b>	<b>60</b>	<b>90</b>	<b>120</b>	<b>180</b>	<b>300</b>	<b>360</b>
<b>VHI206C-□E</b>		1.94	2.3	3.5	5.8	6.9	11.5	13.2	22	33	45	53	53	53
		0.22	0.26	0.4	0.66	0.79	1.3	1.5	2.5	3.8	5.1	6	6	6

- Gearheads and decimal gearheads are sold separately. Decimal gearheads are not available for **V** Series.
- Enter the gear ratio in the box (□) within the model name. A colored background indicates gear shaft rotation in the same direction as the motor shaft; a white background indicates rotation in the opposite direction.
- The speed is calculated by dividing the motor's synchronous speed (50 Hz: 1500 r/min, 60 Hz: 1800 r/min) by the gear ratio. The actual speed is 2~20% less than the displayed value, depending on the size of the load.

## ■ Permissible Overhung Load and Permissible Thrust Load

Motor (Round shaft type) → Page A-11

Gearhead → Page A-11

## ■ Permissible Load Inertia J for Gearhead

→ Page A-12

## Dimensions Scale 1/4, Unit = inch (mm)

Mounting screws are included with gearheads. Dimensions for screws → A-223

### World K Series

#### Lead Wire Type

<b>Motor</b>	<b>Gearhead</b>
<b>2IK6GN-AWU</b>	<b>2GN□KA</b>
<b>2IK6GN-CWE</b>	<b>2GN□KA</b>
<b>2IK6GN-SW</b>	<b>2GN□KA</b>
Weight: 1.5 lb. (0.7 kg)	Weight: 0.88 lb. (0.4 kg)

**DXF** A004AU (2GN3KA~18KA)  
A004BU (2GN25KA~180KA)

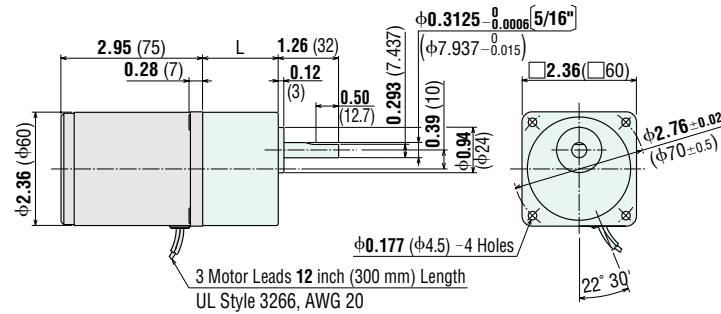

**2GN3KA-18KA:** L = 1.18 (30)  
**2GN25KA-180KA:** L = 1.57 (40)

#### Terminal Box Type

<b>Motor</b>	<b>Gearhead</b>
<b>2IK6GN-AWTU</b>	<b>2GN□KA</b>
<b>2IK6GN-CWTE</b>	<b>2GN□KA</b>
<b>2IK6GN-SWT</b>	<b>2GN□KA</b>
Weight: 1.7 lb. (0.75 kg)	Weight: 0.88 lb. (0.4 kg)

**DXF** A005AU (2GN3KA~18KA)  
A005BU (2GN25KA~180KA)

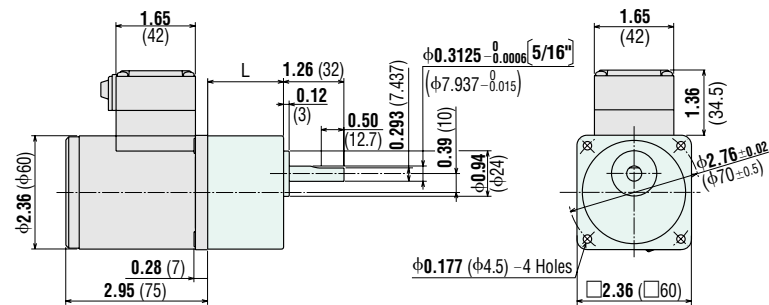

**2GN3KA-18KA:** L = 1.18 (30)  
**2GN25KA-180KA:** L = 1.57 (40)

- Use cable (VCTF) with a diameter of  $\phi 0.27$  inch ( $\phi 6.8$  mm)~ $\phi 0.34$  inch ( $\phi 8.6$  mm).
- Cable entry is possible at any of the four sides of the terminal box.
- Details of Terminal Box → Page A-224

### Decimal Gearhead (for World K Series)

**2GN10XK** Weight: 0.44 lb. (0.2 kg)

**DXF** A003

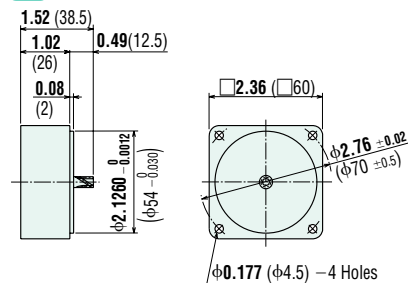

### Round Shaft Type

**2IK6A-AWU**  
**2IK6A-CWE**  
**2IK6A-SW**  
Weight: 1.5 lb. (0.7 kg)

**DXF** A324

1/4 inch shaft motors are also available. Contact your Oriental Motor Representative for more information.

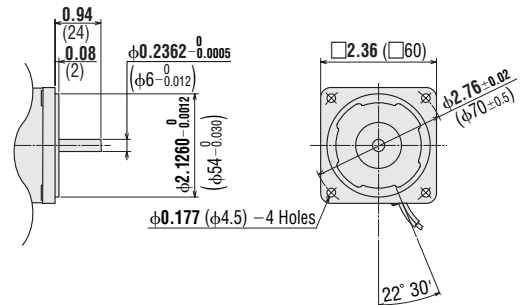

### Round Shaft Type

**2IK6A-AWTU**  
**2IK6A-CWTE**  
**2IK6A-SWT**  
Weight: 1.7 lb. (0.75 kg)

**DXF** A325

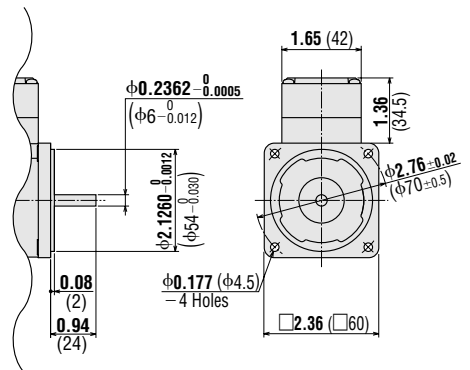

● V Series

◆ Lead Wire Type

VHI206A-□U, VHI206C-□E

(Combination Type)  
Weight: 2.6 lb. (1.2 kg)  
including gearhead

Motor Model:  
VHI206A-GV, VHI206C-GV  
Gearhead Model: GV2G□

- DXF A201A (GV2G5~18)  
A201B (GV2G30~120)  
A201C (GV2G180~360)

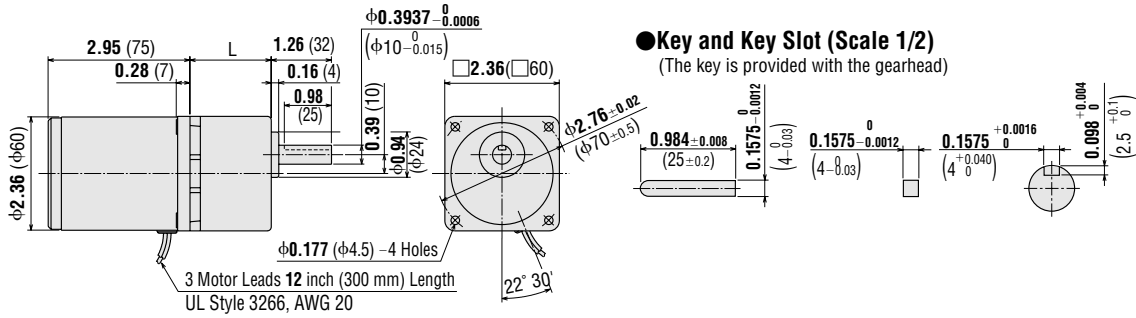

● Key and Key Slot (Scale 1/2)  
(The key is provided with the gearhead)

GV2G5~GV2G18: L = 1.34 (34)  
GV2G30~GV2G120: L = 1.5 (38)  
GV2G180~GV2G360: L = 1.69 (43)

● Capacitor (included with single-phase motors)

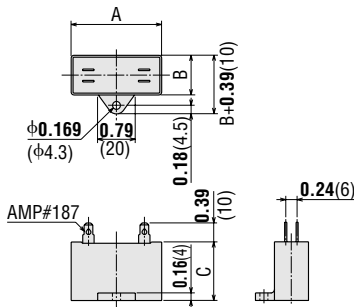

Motor Model	Capacitor Model	Dimensions inch (mm)			Weight oz. (g)
		A	B	C	
21K6GN-AW(T)U 21K6A-AW(T)U VHI206A-□U	CH25FAUL	1.22 (31)	0.67 (17)	1.06 (27)	0.71 (20)
21K6GN-CW(T)E 21K6A-CW(T)E VHI206C-□E	CH06BFAUL	1.22 (31)	0.57 (14.5)	0.93 (23.5)	0.53 (15)

● If you need to order a capacitor without a motor, add "-C" to the capacitor model name shown. A capacitor cap is included with a capacitor.

■ Connection Diagrams

Lead Wire Type		Terminal Box Type	
<p>21K6GN-AWU 21K6GN-CWE VHI206A-□U VHI206C-□E</p> <p>To rotate the motor in a clockwise (CW) direction, flip switch SW to CW. To rotate it in a counterclockwise (CCW) direction, flip switch SW to CCW.</p>	<p>21K6GN-SW</p> <p>To change the rotation direction, change any two connections between U, V and W.</p>	<p>21K6GN-AWTU 21K6GN-CWTE</p> <p>To rotate the motor in a clockwise (CW) direction, flip switch SW to CW. To rotate it in a counterclockwise (CCW) direction, flip switch SW to CCW.</p>	<p>21K6GN-SWT</p> <p>To change the rotation direction, change any two connections between U, V and W.</p>

- The direction of motor rotation is as viewed from the shaft end of the motor.
- CW represents the clockwise direction, while CCW represents the counterclockwise direction.
- Connection diagrams are also valid for the equivalent round shaft type.
- How to connect a capacitor → Page A-225

Note:

- Change the direction of single-phase motor rotation only after bringing the motor to a stop. If an attempt is made to change the direction of rotation while the motor is rotating, the motor may ignore the reversing command or change its direction of rotation after some delay.

● Inner Connection Diagram for 4-Terminal Capacitor

Terminals of the capacitor are connected as shown in the figure. For lead wire connection, use one lead wire per terminal.

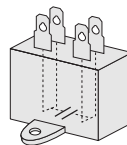

■ List of Motor and Gearhead Combinations for V Series

Model numbers for motor and gearhead combinations are shown below.

Model	Motor Model	Gearhead Model
VHI206A-□U	VHI206A-GV	GV2G□
VHI206C-□E	VHI206C-GV	

- Enter the gear ratio in the box (□) within the model name.

# Induction Motors

## 15 W (1/50 HP)

Frame Size: □ 2.76 in. (□ 70 mm)

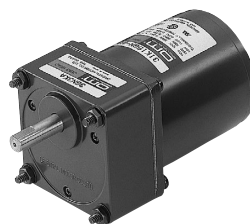

World **K** Series  
(Gearhead Sold Separately)



**V** Series/Combination Type  
(Pre-assembled Gearmotor)

### Specifications — Continuous Rating

#### World K Series (General Purpose)



Model Upper Model Name: Pinion Shaft Type Lower Model Name( ): Round Shaft Type	Output Power		Voltage	Frequency	Current	Starting Torque		Rated Torque		Rated Speed	Capacitor
	HP	W	VAC	Hz	A	oz-in	mN·m	oz-in	mN·m	r/min	μF
(TP) <b>3IK15GN-AWU</b> (3IK15A-AWU)	1/50 15		Single-Phase 110	60	0.33	9.2	65	14.9	105	1450	4.5
			Single-Phase 115		0.34						
(TP) <b>3IK15GN-CWE</b> (3IK15A-CWE)	1/50 15		Single-Phase 220	50	0.19	9.9	70	17.7	125	1200	1
			Single-Phase 220	60	0.16	9.2	65	14.9	105	1450	
			Single-Phase 230	50	0.19	10.6	75	17.7	125	1200	
			Single-Phase 230	60	0.16	9.2	65	14.9	105	1450	

(TP) Contains a built-in thermal protector. If a motor overheats for any reason, the thermal protector is opened and the motor stops. When the motor temperature drops, the thermal protector closes and the motor restarts. Be sure to turn the motor off before inspecting.

• The "U" and "E" at the end of the model name indicate that the unit includes a capacitor. These two letters are not listed on the motor nameplate.

When the motor is approved under various safety standards, the model name on the nameplate is the approved model name. →Page G-10

• Details of Safety Standard →Page G-2

#### V Series (Quiet Operation, High Strength, Long Life)



Model Combination Type	Output Power		Voltage	Frequency	Current	Starting Torque		Rated Torque		Rated Speed	Capacitor
	HP	W	VAC	Hz	A	oz-in	mN·m	oz-in	mN·m	r/min	μF
(TP) <b>VHI315A-□U</b>	1/50 15		Single-Phase 110	60	0.33	9.2	65	14.9	105	1450	4.5
			Single-Phase 115		0.34						
(TP) <b>VHI315C-□E</b>	1/50 15		Single-Phase 220	50	0.19	9.9	70	17.7	125	1200	1
			Single-Phase 220	60	0.16	9.2	65	14.9	105	1450	
			Single-Phase 230	50	0.19	10.6	75	17.7	125	1200	
			Single-Phase 230	60	0.16	9.2	65	14.9	105	1450	

(TP) Contains a built-in thermal protector. If a motor overheats for any reason, the thermal protector is opened and the motor stops. When the motor temperature drops, the thermal protector closes and the motor restarts. Be sure to turn the motor off before inspecting.

• The "U" and "E" at the end of the model name indicate that the unit includes a capacitor. These two letters are not listed on the motor nameplate.

When the motor is approved under various safety standards, the model name on the nameplate is the approved model name. →Page G-11

• Details of Safety Standard →Page G-2

• Models above are provided as combination type with motor and gearhead pre-assembled.

• Enter gear ratio in the box (□) within the model name.

• The values in the table are for the motor only.

### Gearheads for World K Series (Sold Separately)

#### Parallel Shaft

Gearhead Model	Gear Ratio
<b>3GN□KA</b>	<b>3~180</b>
<b>3GN10XK</b> (Decimal Gearhead)	

• Enter the gear ratio in the box (□) within the model name.

## ■ Gearmotor — Torque Table

### ● World K Series (General Purpose)

The maximum permissible torque with a decimal gearhead with a gear ratio of 10:1 is 44 lb-in (5 N·m).

#### ◆ Single-Phase 115/230 VAC 60 Hz

Unit = Upper values: lb-in/Lower values: N·m

Model	Speed r/min	600	500	360	300	240	200	144	120	100	72	60	50	36	30	24	20	18	15	12	10
	Gear Ratio	<b>3</b>	<b>3.6</b>	<b>5</b>	<b>6</b>	<b>7.5</b>	<b>9</b>	<b>12.5</b>	<b>15</b>	<b>18</b>	<b>25</b>	<b>30</b>	<b>36</b>	<b>50</b>	<b>60</b>	<b>75</b>	<b>90</b>	<b>100</b>	<b>120</b>	<b>150</b>	<b>180</b>
<b>3IK15GN-AWU</b> <b>3IK15GN-CWE</b> / <b>3GN□KA</b>		2.3 0.26	2.7 0.31	3.8 0.43	4.5 0.51	5.6 0.64	6.8 0.77	9.7 1.1	11.5 1.3	13.2 1.5	16.8 1.9	20 2.3	24 2.8	30 3.5	37 4.2	44 5	44 5	44 5	44 5	44 5	44 5

#### ◆ Single-Phase 230 VAC 50 Hz

Unit = Upper values: lb-in/Lower values: N·m

Model	Speed r/min	500	416	300	250	200	166	120	100	83	60	50	41	30	25	20	16	15	12.5	10	8.3
	Gear Ratio	<b>3</b>	<b>3.6</b>	<b>5</b>	<b>6</b>	<b>7.5</b>	<b>9</b>	<b>12.5</b>	<b>15</b>	<b>18</b>	<b>25</b>	<b>30</b>	<b>36</b>	<b>50</b>	<b>60</b>	<b>75</b>	<b>90</b>	<b>100</b>	<b>120</b>	<b>150</b>	<b>180</b>
<b>3IK15GN-CWE</b> / <b>3GN□KA</b>		2.6 0.30	3.1 0.36	4.5 0.51	5.3 0.61	6.7 0.76	8 0.91	11.5 1.3	13.2 1.5	15.9 1.8	20 2.3	23 2.7	29 3.3	36 4.1	44 5	44 5	44 5	44 5	44 5	44 5	44 5

### ● V Series (Quiet Operation, High Strength, Long Life)

#### ◆ Single-Phase 115/230 VAC 60 Hz

Unit = Upper values: lb-in/Lower values: N·m

Model	Speed r/min	360	300	200	120	100	60	50	30	20	15	10	6	5
	Gear Ratio	<b>5</b>	<b>6</b>	<b>9</b>	<b>15</b>	<b>18</b>	<b>30</b>	<b>36</b>	<b>60</b>	<b>90</b>	<b>120</b>	<b>180</b>	<b>300</b>	<b>360</b>
<b>VHI315A-□U</b> <b>VHI315C-□E</b>		4.1 0.47	5 0.57	7.5 0.85	12.3 1.4	15 1.7	23 2.7	29 3.3	47 5.4	71 8.1	88 10	88 10	88 10	88 10

#### ◆ Single-Phase 230 VAC 50 Hz

Unit = Upper values: lb-in/Lower values: N·m

Model	Speed r/min	300	250	166	100	83	50	41	25	16	12.5	8.3	5	4.2
	Gear Ratio	<b>5</b>	<b>6</b>	<b>9</b>	<b>15</b>	<b>18</b>	<b>30</b>	<b>36</b>	<b>60</b>	<b>90</b>	<b>120</b>	<b>180</b>	<b>300</b>	<b>360</b>
<b>VHI315C-□E</b>		4.9 0.56	6 0.68	8.8 1	15 1.7	17.7 2	28 3.2	34 3.9	57 6.5	85 9.7	88 10	88 10	88 10	88 10

- Gearheads and decimal gearheads are sold separately. Decimal gearheads are not available for **V** Series.
- Enter the gear ratio in the box (□) within the model name. A colored background indicates gear shaft rotation in the same direction as the motor shaft; a white background indicates rotation in the opposite direction.
- The speed is calculated by dividing the motor's synchronous speed (50 Hz: 1500 r/min, 60 Hz: 1800 r/min) by the gear ratio. The actual speed is 2~20% less than the displayed value, depending on the size of the load.

## ■ Permissible Overhung Load and Permissible Thrust Load

Motor (Round shaft type) → Page A-11

Gearhead → Page A-11

## ■ Permissible Load Inertia J for Gearhead

→ Page A-12

**Dimensions** Scale 1/4, Unit = inch (mm)

Mounting screws are included with gearheads. Dimensions for screws →A-223

● **World K Series**

◆ **Lead Wire Type**

**Motor**  
**3IK15GN-AWU** / **Gearhead**  
**3IK15GN-CWE** / **3GN□KA**  
 Weight: 2.4 lb. (1.1 kg) / Weight: 1.2 lb. (0.55 kg)

**DXF** A010AU (**3GN3KA~18KA**)  
 A010BU (**3GN25KA~180KA**)

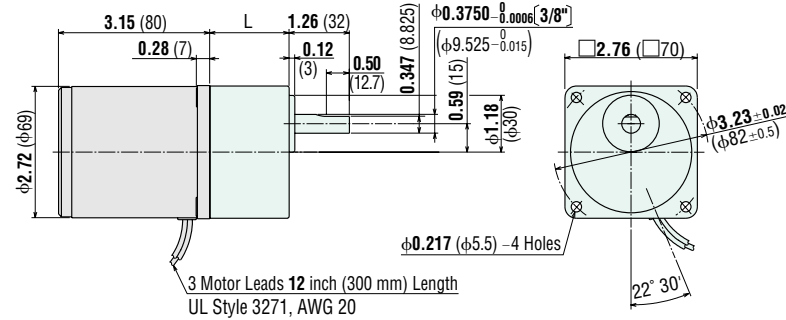

**3GN3KA-18KA:** L = 1.26 (32)  
**3GN25KA-180KA:** L = 1.65 (42)

**Round Shaft Type**

**3IK15A-AWU**  
**3IK15A-CWE**  
 Weight: 2.4 lb. (1.1 kg)

**DXF** A326

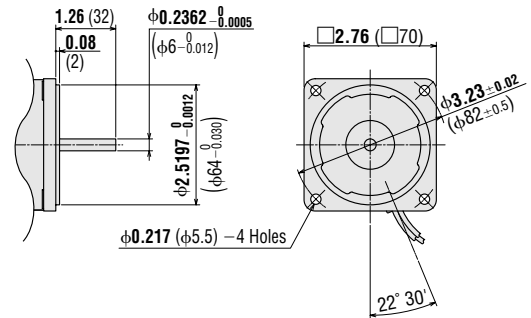

1/4 inch shaft motors are also available. Contact your Oriental Motor Representative for more information.

● **Decimal Gearhead (for World K Series)**

**3GN10XK** Weight: 0.66 lb. (0.3 kg)

**DXF** A009

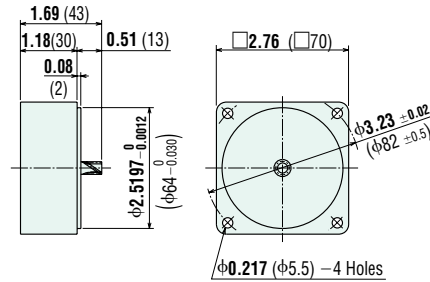

● **V Series**

◆ **Lead Wire Type**

**VHI315A-□U, VHI315C-□E** (Combination Type)  
 Weight: 3.7 lb. (1.7 kg) including gearhead  
 Motor Model: VHI315A-GV, VHI315C-GV  
 Gearhead Model: GV3G□

**DXF** A242A (GV3G5~18)  
 A242B (GV3G30~120)  
 A242C (GV3G180~360)

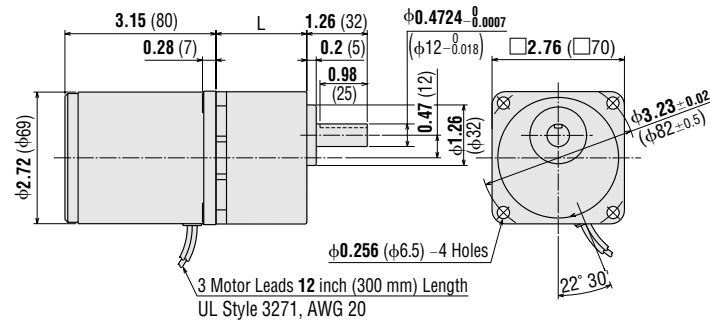

GV3G5-GV3G18: L = 1.5 (38)  
 GV3G30-GV3G120: L = 1.69 (43)  
 GV3G180-GV3G360: L = 1.89 (48)

● **Key and Key Slot (Scale 1/2)**

(The key is provided with the gearhead)

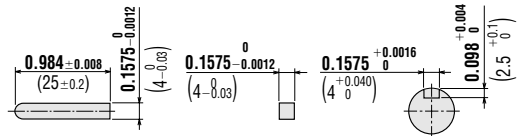

● **Capacitor** (included with the motors)

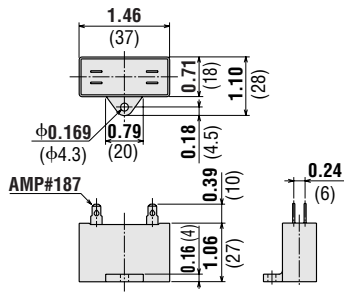

Motor Model	Capacitor Model	Weight oz. (g)
<b>3IK15GN-AWU</b> <b>3IK15A-AWU</b> <b>VHI315A-□-U</b>	CH45FAUL	1.1 (30)
<b>3IK15GN-CWE</b> <b>3IK15A-CWE</b> <b>VHI315C-□-E</b>	CH10BFAUL	1.1 (30)

● If you need to order a capacitor without a motor, add "-C" to the capacitor model name shown. A capacitor cap is included with a capacitor.

■ **Connection Diagrams**

Lead Wire Type
<b>3IK15GN-AWU</b> <b>3IK15GN-CWE</b> <b>VHI315A-□-U</b> <b>VHI315C-□-E</b>

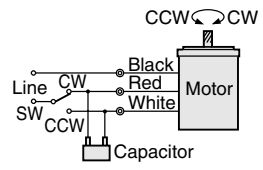

To rotate the motor in a clockwise (CW) direction, flip switch SW to CW.  
To rotate it in a counterclockwise (CCW) direction, flip switch SW to CCW.

- The direction of motor rotation is as viewed from the shaft end of the motor.
- CW represents the clockwise direction, while CCW represents the counterclockwise direction.
- Connection diagrams are also valid for the equivalent round shaft type.
- **How to connect a capacitor** → Page A-225

**Note:**

- Change the direction of motor rotation only after bringing the motor to a stop.  
If an attempt is made to change the direction of rotation while the motor is rotating, the motor may ignore the reversing command or change its direction of rotation after some delay.

● **Inner Connection Diagram for 4-Terminal Capacitor**

Terminals of the capacitor are connected as shown in the figure. For lead wire connection, use one lead wire per terminal.

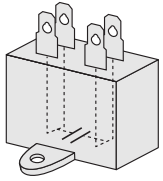

■ **List of Motor and Gearhead Combinations for V Series**

Model numbers for motor and gearhead combinations are shown below.

Model	Motor Model	Gearhead Model
<b>VHI315A-□-U</b>	VHI315A-GV	GV3G□
<b>VHI315C-□-E</b>	VHI315C-GV	

- Enter the gear ratio in the box (□) within the model name.

# Induction Motors

## 25 W (1/30 HP)

Frame Size: □ 3.15 in. (□ 80 mm)



World **K** Series  
(Gearhead Sold Separately)



**V** Series/Combination Type  
(Pre-assembled Gearmotor)

### Specifications — Continuous Rating

#### World K Series (General Purpose)



Model			Output Power		Voltage	Frequency	Current	Starting Torque	Rated Torque	Rated Speed	Capacitor			
Upper Model Name: Pinion Shaft Type Lower Model Name( ): Round Shaft Type			HP	W	VAC	Hz	A	oz-in	mN·m	oz-in	mN·m	r/min	μF	
Lead Wire Type Dimension ①	Terminal Box Type Dimension ②	Conduit Box Type Dimension ③												
TP 4IK25GN-AWU (4IK25A-AWU)	4IK25GN-AWTU (4IK25A-AWTU)	4IK25GN-FCH (4IK25AA-FCH)	1/30	25	Single-Phase 110		60	0.46	17	120	24	170	1450	6.5
Single-Phase 115		60			Single-Phase 220*		50				29	205	1200	
TP 4IK25GN-CWE (4IK25A-CWE)	4IK25GN-CWTE (4IK25A-CWTE)	4IK25GN-ECH* (4IK25AA-ECH)*			Single-Phase 220		60	0.22	17	120	24	170	1450	1.5
Single-Phase 230		50			0.24	29	205	1200						
Single-Phase 230		60			0.22	24	170	1450						
TP 4IK25GN-SW (4IK25A-SW)	4IK25GN-SWT (4IK25A-SWT)	4IK25GN-SH (4IK25AA-SH)			Three-Phase 200		50	0.23	34	240	26	190	1300	—
Three-Phase 200		60	0.21	22	160	22	160	1550						
Three-Phase 220		60	0.21	22	160	22	160	1600						
Three-Phase 230		60	0.22	22	160	22	160	1600						

TP Contains a built-in thermal protector. If a motor overheats for any reason, the thermal protector is opened and the motor stops. When the motor temperature drops, the thermal protector closes and the motor restarts. Be sure to turn the motor off before inspecting.

The "U" and "E" at the end of the model name indicate that the unit includes a capacitor. These two letters are not listed on the motor nameplate.

When the motor is approved under various safety standards, the model name on the nameplate is the approved model name. →Page G-10

Details of Safety Standard →Page G-2

\* The conduit box type motors are not VDE approved. The conduit box type does not have a specification for Single-Phase 220 VAC 50 Hz.



#### V Series (Quiet Operation, High Strength, Long Life)

Model			Output Power		Voltage	Frequency	Current	Starting Torque	Rated Torque	Rated Speed	Capacitor		
Combination Type			HP	W	VAC	Hz	A	oz-in	mN·m	oz-in	mN·m	r/min	μF
Lead Wire Type Dimension ④	Terminal Box Type Dimension ⑤												
TP VH1425A-□U	VH1425AT-□U	1/30	25	Single-Phase 110		60	0.46	17	120	24	170	1450	6.5
Single-Phase 115				60	Single-Phase 220					50	29	205	
TP VH1425C-□E	VH1425CT-□E			Single-Phase 220		60	0.22	17	120	24	170	1450	1.5
Single-Phase 230				50	0.24	29	205			1200			
Single-Phase 230				60	0.22	24	170			1450			
TP VH1425S-□	VH1425ST-□			Three-Phase 200		50	0.23	34	240	26	190	1300	—
Three-Phase 200		60	0.21	22	160	22	160	1550					
Three-Phase 220		60	0.21	22	160	22	160	1600					
Three-Phase 230		60	0.22	22	160	22	160	1600					

TP Contains a built-in thermal protector. If a motor overheats for any reason, the thermal protector is opened and the motor stops. When the motor temperature drops, the thermal protector closes and the motor restarts. Be sure to turn the motor off before inspecting.

The "U" and "E" at the end of the model name indicate that the unit includes a capacitor. These two letters are not listed on the motor nameplate.

When the motor is approved under various safety standards, the model name on the nameplate is the approved model name. →Page G-11

Details of Safety Standard →Page G-2

Models above are provided as combination type with motor and gearhead pre-assembled.

Enter gear ratio in the box (□) within the model name.

The values in the table are for the motor only.

### Gearhead for World K Series (Sold Separately)

#### Parallel Shaft

Gearhead Model	Gear Ratio
4GN□KA	3~180
4GN10XK (Decimal Gearhead)	

Enter the gear ratio in the box (□) within the model name.

#### Right-Angle

Type	Gearhead Model	Gear Ratio
Hollow Shaft	4GN□RH	3.6~180
Solid Shaft	4GN□RAA	3.6~180

Enter the gear ratio in the box (□) within the model name.

Right-Angle Gearheads →Page A-189



## ■ Gearmotor — Torque Table

### ● World K Series (General Purpose)

The maximum permissible torque with a decimal gearhead with a gear ratio of 10:1 is 70 lb-in (8 N·m).

The value is 53 lb-in (6 N·m) when 25:1~36:1 gearheads are connected.

#### ◆ Single-Phase 115/230 VAC 60 Hz, Three-Phase 230 VAC 60 Hz

Unit = Upper values: lb-in/Lower values: N·m

Model	Speed r/min	600	500	360	300	240	200	144	120	100	72	60	50	36	30	24	20	18	15	12	10	
	Gear Ratio	<b>3</b>	<b>3.6</b>	<b>5</b>	<b>6</b>	<b>7.5</b>	<b>9</b>	<b>12.5</b>	<b>15</b>	<b>18</b>	<b>25</b>	<b>30</b>	<b>36</b>	<b>50</b>	<b>60</b>	<b>75</b>	<b>90</b>	<b>100</b>	<b>120</b>	<b>150</b>	<b>180</b>	
4IK25GN-AWU 4IK25GN-AWTU 4IK25GN-CWE 4IK25GN-CWTE 4IK25GN-FCH 4IK25GN-ECH	4GN□KA	3.6	4.4	6.1	7.3	8.8	10.6	15	18.5	22	27	32	39	49	59	70	70	70	70	70	70	
		0.41	0.50	0.69	0.83	1.0	1.2	1.7	2.1	2.5	3.1	3.7	4.5	5.6	6.7	8	8	8	8	8	8	
		3.4	4.1	5.7	6.9	8.5	10.6	14.1	16.8	20	25	30	37	46	55	69	70	70	70	70	70	70
		0.39	0.47	0.65	0.78	0.97	1.2	1.6	1.9	2.3	2.9	3.5	4.2	5.3	6.3	7.9	8	8	8	8	8	8

#### ◆ Single-Phase 230 VAC 50 Hz

Unit = Upper values: lb-in/Lower values: N·m

Model	Speed r/min	500	416	300	250	200	166	120	100	83	60	50	41	30	25	20	16	15	12.5	10	8.3
	Gear Ratio	<b>3</b>	<b>3.6</b>	<b>5</b>	<b>6</b>	<b>7.5</b>	<b>9</b>	<b>12.5</b>	<b>15</b>	<b>18</b>	<b>25</b>	<b>30</b>	<b>36</b>	<b>50</b>	<b>60</b>	<b>75</b>	<b>90</b>	<b>100</b>	<b>120</b>	<b>150</b>	<b>180</b>
4IK25GN-CWE 4IK25GN-CWTE 4IK25GN-ECH	4GN□KA	4.4	5.3	7.3	8.8	10.6	13.2	18.5	22	26	32	39	47	60	70	70	70	70	70	70	70
		0.50	0.60	0.83	1.0	1.2	1.5	2.1	2.5	3.0	3.7	4.5	5.4	6.8	8	8	8	8	8	8	8

### ● V Series (Quiet Operation, High Strength, Long Life)

#### ◆ Single-Phase 115/230 VAC 60 Hz, Three-Phase 230 VAC 60 Hz

Unit = Upper values: lb-in/Lower values: N·m

Model	Speed r/min	360	300	200	120	100	60	50	30	20	15	10	6	5
	Gear Ratio	<b>5</b>	<b>6</b>	<b>9</b>	<b>15</b>	<b>18</b>	<b>30</b>	<b>36</b>	<b>60</b>	<b>90</b>	<b>120</b>	<b>180</b>	<b>300</b>	<b>360</b>
VHI425A-□U VHI425C-□E VHI425AT-□U VHI425CT-□E	□	6.8	8.1	12.3	20	24	38	46	77	116	141	141	141	141
		0.77	0.92	1.4	2.3	2.8	4.4	5.3	8.8	13.2	16	16	16	16
VHI425S-□ VHI425ST-□	□	6.3	7.6	11.5	19.4	23	36	44	73	109	141	141	141	141
		0.72	0.86	1.3	2.2	2.6	4.1	5	8.3	12.4	16	16	16	16

#### ◆ Single-Phase 230 VAC 50 Hz

Unit = Upper values: lb-in/Lower values: N·m

Model	Speed r/min	300	250	166	100	83	50	41	25	16	12.5	8.3	5	4.2
	Gear Ratio	<b>5</b>	<b>6</b>	<b>9</b>	<b>15</b>	<b>18</b>	<b>30</b>	<b>36</b>	<b>60</b>	<b>90</b>	<b>120</b>	<b>180</b>	<b>300</b>	<b>360</b>
VHI425C-□E VHI425CT-□E	□	8.1	9.7	15	24	29	46	55	93	140	141	141	141	141
		0.92	1.1	1.7	2.8	3.3	5.3	6.3	10.6	15.9	16	16	16	16

- Gearheads and decimal gearheads are sold separately. Decimal gearheads are not available for V Series.
- Enter the gear ratio in the box (□) within the model name. A colored background indicates gear shaft rotation in the same direction as the motor shaft; a white background indicates rotation in the opposite direction.
- The speed is calculated by dividing the motor's synchronous speed (50 Hz: 1500 r/min, 60 Hz: 1800 r/min) by the gear ratio. The actual speed is 2~20% less than the displayed value, depending on the size of the load.

## ■ Gearmotor — Torque Table when Right-Angle Gearhead is Attached

Right-Angle Gearheads are available for the World K Series only.

→Page A-196

## ■ Permissible Overhung Load and Permissible Thrust Load

Motor (Round shaft type)→Page A-11

Gearhead→Page A-11

## ■ Permissible Load Inertia J for Gearhead

→Page A-12

## Dimensions Scale 1/4, Unit = inch (mm)

Mounting screws are included with gearheads. Dimensions for screws → A-223

### World K Series

#### Lead Wire Type

Motor	Gearhead
41K25GN-AWU	4GN□KA
41K25GN-CWE	4GN□KA
41K25GN-SW	4GN□KA
Weight: 3.3 lb. (1.5 kg)	Weight: 1.4 lb. (0.65 kg)

**DXF** A014AU (4GN3KA~18KA)  
A014BU (4GN25KA~180KA)

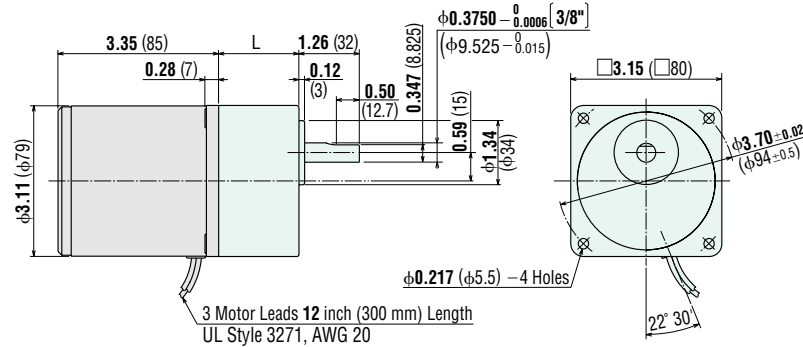

**4GN3KA-18KA:** L = 1.26 (32)  
**4GN25KA-180KA:** L = 1.67 (42.5)

#### Terminal Box Type

Motor	Gearhead
41K25GN-AWTU	4GN□KA
41K25GN-CWTE	4GN□KA
41K25GN-SWT	4GN□KA
Weight: 3.7 lb. (1.7 kg)	Weight: 1.4 lb. (0.65 kg)

**DXF** A015AU (4GN3KA~18KA)  
A015BU (4GN25KA~180KA)

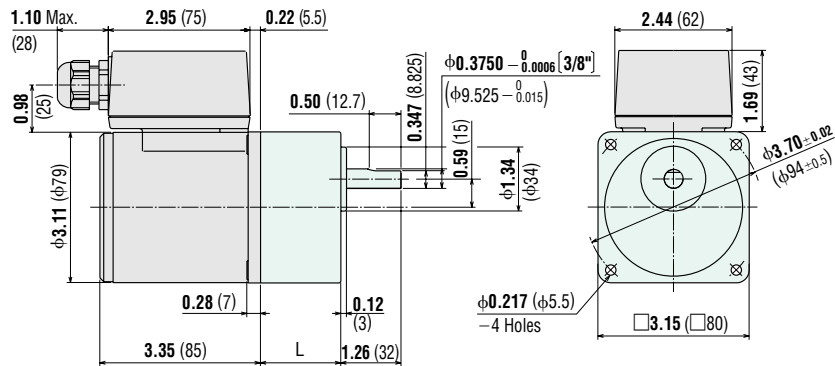

**4GN3KA-18KA:** L = 1.26 (32)  
**4GN25KA-180KA:** L = 1.67 (42.5)

- Use cable (VCTF) with a diameter of  $\phi 0.24$  inch ( $\phi 6$  mm)~ $\phi 0.47$  inch ( $\phi 12$  mm).
- Details of Terminal Box → Page A-224

#### Round Shaft Type

41K25A-AWU
41K25A-CWE
41K25A-SW
Weight: 3.3 lb. (1.5 kg)

**DXF** A327

5/16 inch shaft motors are also available. Contact your Oriental Motor Representative for more information.

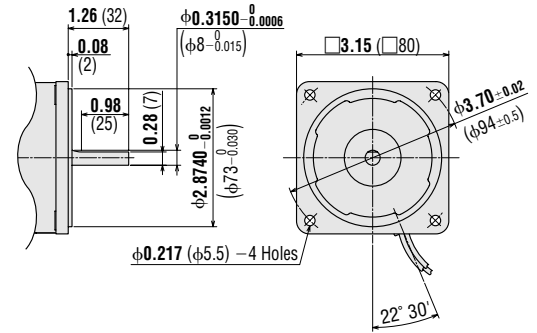

#### Round Shaft Type

41K25A-AWTU
41K25A-CWTE
41K25A-SWT
Weight: 3.7 lb. (1.7 kg)

**DXF** A328

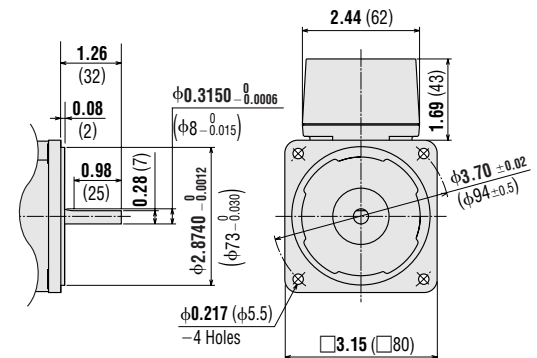

◆ Conduit Box Type

**Motor**

**4IK25GN-FCH**

**4IK25GN-ECH**

Weight: 4.2 lb. (1.9 kg)

**Gearhead**

**4GN□KA**

Weight: 1.4 lb. (0.65 kg)

**DXF** A800A (**4GN3KA~18KA**)  
A800B (**4GN25KA~180KA**)

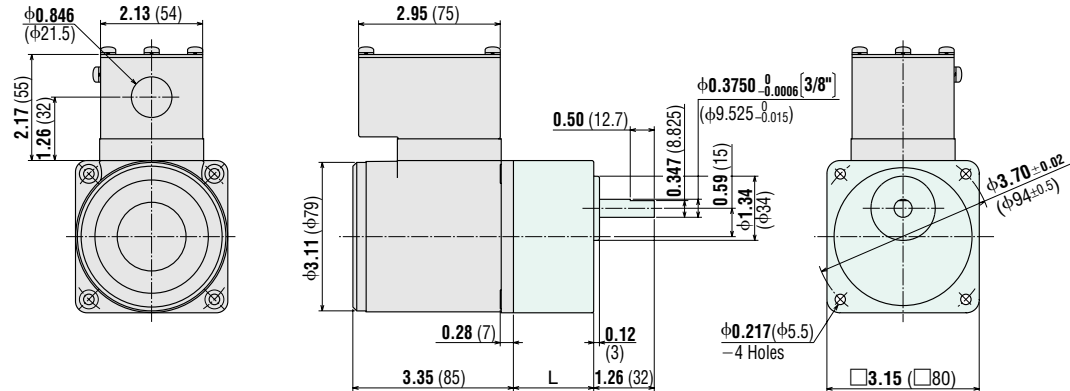

**4GN3KA-18KA:** L = 1.26 (32)  
**4GN25KA-180KA:** L = 1.67 (42.5)

3 Motor Leads: UL Style 3266, AWG 20  
1 Ground Lead: UL Style 3266, AWG 18

●Details of Terminal Box → Page A-224

**Motor**

**4IK25GN-SH**

Weight: 3.7 lb. (1.7 kg)

**Gearhead**

**4GN□KA**

Weight: 1.4 lb. (0.65 kg)

**DXF** A801A (**4GN3KA~18KA**)  
A801B (**4GN25KA~180KA**)

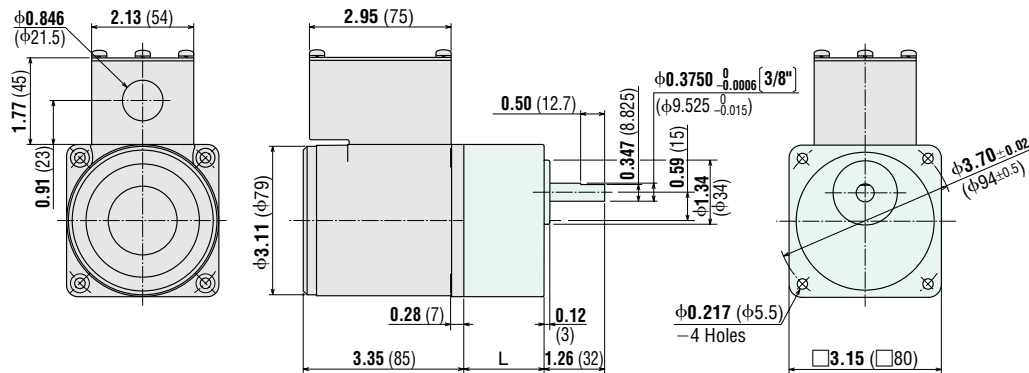

**4GN3KA~18KA:** L = 1.26 (32)  
**4GN25KA~180KA:** L = 1.67 (42.5)

3 Motor Leads: UL Style 3266, AWG 20  
1 Ground Lead: UL Style 3266, AWG 18

●Details of Terminal Box → Page A-224

**Round Shaft Type**

**4IK25AA-FCH**

**4IK25AA-ECH**

Weight: 4.2 lb. (1.9 kg)

**DXF** A809

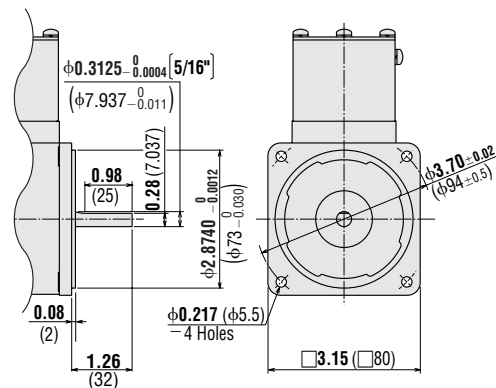

**Round Shaft Type**

**4IK25AA-SH**

Weight: 3.7 lb. (1.7 kg)

**DXF** A810

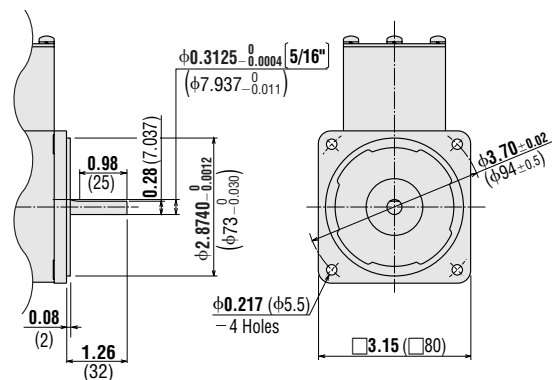

● **Decimal Gearhead (for World K Series)**

**4GN10XK** Weight: 0.88 lb. (0.4 kg)

**DXF** A013

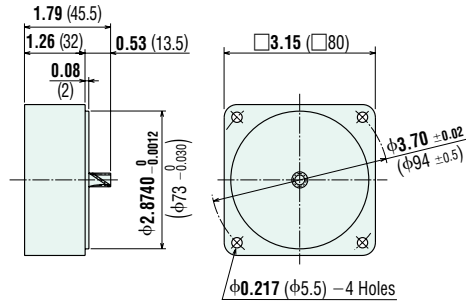

● **V Series**

◆ **Lead Wire Type**

**VHI425A-U, VHI425C-E, VHI425S-** (Combination Type)

Weight: 5.5 lb. (2.5 kg) including gearhead

Motor Model: VHI425A-GV, VHI425C-GV, VHI425S-GV

Gearhead Model: GV4G□

**DXF** A202A (GV4G5~18)  
A202B (GV4G30~120)  
A202C (GV4G180~360)

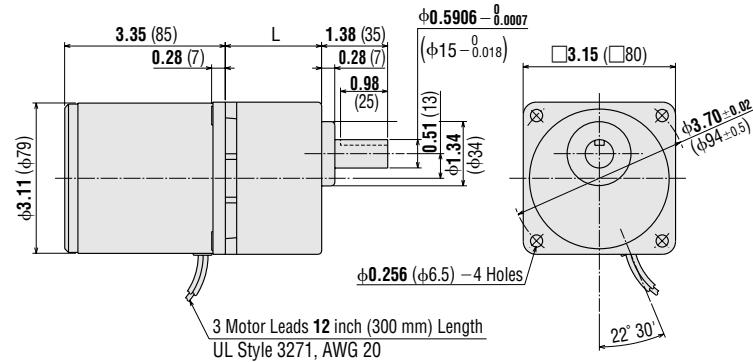

GV4G5-GV4G18: L = 1.61 (41)  
GV4G30-GV4G120: L = 1.81 (46)  
GV4G180-GV4G360: L = 2.01 (51)

● **Key and Key Slot (Scale 1/2)**

(The key is provided with the gearhead)

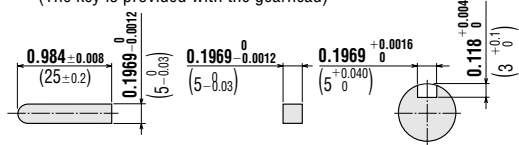

◆ **Terminal Box Type**

**VHI425AT-U, VHI425CT-E, VHI425ST-** (Combination Type)

Weight: 5.9 lb. (2.7 kg) including gearhead

Motor Model: VHI425AT-GV, VHI425CT-GV, VHI425ST-GV

Gearhead Model: GV4G□

**DXF** A211A (GV4G5~18)  
A211B (GV4G30~120)  
A211C (GV4G180~360)

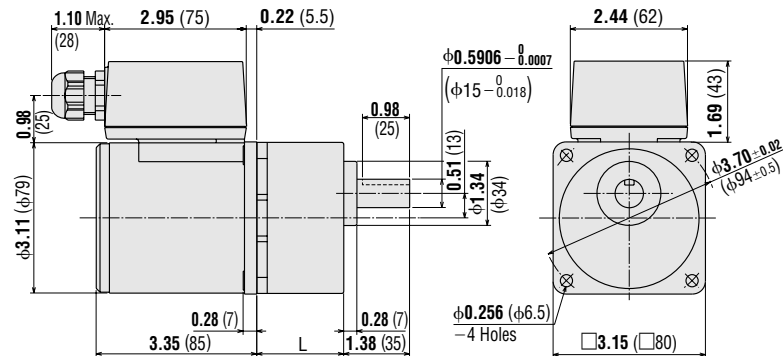

GV4G5-GV4G18: L = 1.61 (41)  
GV4G30-GV4G120: L = 1.81 (46)  
GV4G180-GV4G360: L = 2.01 (51)

- Use cable (VCTF) with a diameter of  $\phi 0.24$  inch ( $\phi 6$  mm)~ $\phi 0.47$  inch ( $\phi 12$  mm).
- Details of Terminal Box → Page A-224

● **Key and Key Slot (Scale 1/2)**

(The key is provided with the gearhead)

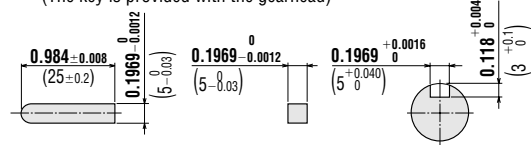

**Capacitor** (included with single-phase motors)

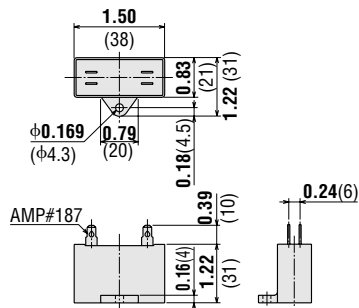

Motor Model	Capacitor Model	Weight oz. (g)
<b>4IK25GN-AW(T)U</b> <b>4IK25A-AW(T)U</b> <b>VHI425A(T)-□U</b>	CH65CFAUL	1.2 (35)
<b>4IK25GN-CW(T)E</b> <b>4IK25A-CW(T)E</b> <b>VHI425C(T)-□E</b>	CH15BFAUL	

• If you need to order a capacitor without a motor, add "-C" to the capacitor model name shown. A capacitor cap is included with a capacitor.

**Connection Diagrams**

Lead Wire Type	
<b>4IK25GN-AWU</b> <b>4IK25GN-CWE</b> <b>VHI425A-□U</b> <b>VHI425C-□E</b>	<b>4IK25GN-SW</b> <b>VHI425S-□</b>
<p>To rotate the motor in a clockwise (CW) direction, flip switch SW to CW. To rotate it in a counterclockwise (CCW) direction, flip switch SW to CCW.</p>	<p>To change the rotation direction, change any two connections between U, V and W.</p>

Terminal Box Type	
<b>4IK25GN-AWTU</b> <b>4IK25GN-CWTE</b> <b>VHI425AT-□U</b> <b>VHI425CT-□E</b>	<b>4IK25GN-SWT</b> <b>VHI425ST-□</b>
<p>To rotate the motor in a clockwise (CW) direction, flip switch SW to CW. To rotate it in a counterclockwise (CCW) direction, flip switch SW to CCW.</p>	<p>To change the rotation direction, change any two connections between U, V and W.</p>

Conduit Box Type	
<b>4IK25GN-FCH</b> <b>4IK25GN-ECH</b>	<b>4IK25GN-SH</b>
<p>To rotate the motor in a clockwise (CW) direction, flip switch SW to CW. To rotate it in a counterclockwise (CCW) direction, flip switch SW to CCW.</p>	<p>To change the rotation direction, change any two connections between U, V and W.</p>

**Inner Connection Diagram for 4-Terminal Capacitor**

Terminals of the capacitor are connected as shown in the figure. For lead wire connection, use one lead wire per terminal.

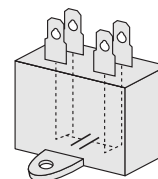

- The direction of motor rotation is as viewed from the shaft end of the motor.
- CW represents the clockwise direction, while CCW represents the counterclockwise direction.
- Connection diagrams are also valid for the equivalent round shaft type.
- **How to connect a capacitor** → Page A-225

**Note:**

- Change the direction of single-phase motor rotation only after bringing the motor to a stop. If an attempt is made to change the direction of rotation while the motor is rotating, the motor may ignore the reversing command or change its direction of rotation after some delay.

**List of Motor and Gearhead Combinations for V Series**

Model numbers for motor and gearhead combinations are shown below.

Model	Motor Model	Gearhead Model
<b>VHI425A-□U</b>	VHI425A-GV	GV4G□
<b>VHI425C-□E</b>	VHI425C-GV	
<b>VHI425S-□</b>	VHI425S-GV	
<b>VHI425AT-□U</b>	VHI425AT-GV	
<b>VHI425CT-□E</b>	VHI425CT-GV	
<b>VHI425ST-□</b>	VHI425ST-GV	

- Enter the gear ratio in the box (□) within the model name.

# Induction Motors

## 40 W (1/19 HP)

Frame Size: □ 3.54 in. (□ 90 mm)



World **K** Series  
(Gearhead Sold Separately)



**V** Series/Combination Type  
(Pre-assembled Gearmotor)

### Specifications — Continuous Rating

#### World K Series (General Purpose)



Model			Output Power	Voltage	Frequency	Current	Starting Torque	Rated Torque	Rated Speed	Capacitor						
Upper Model Name: Pinion Shaft Type Lower Model Name( ): Round Shaft Type			HP	W	VAC	Hz	A	oz-in	mN·m	oz-in	mN·m	r/min	μF			
Lead Wire Type Dimension ①	Terminal Box Type Dimension ②	Conduit Box Type Dimension ③														
(TP) 5IK40GN-AWU (5IK40A-AWU)	5IK40GN-AWTU (5IK40A-AWTU)	5IK40GN-FCH (5IK40AA-FCH)	1/19	40	Single-Phase 110		60	0.68	28	200	36	260	1500	9		
Single-Phase 115																
Single-Phase 220*		50			0.39	28	200	36	260	1500	2.3					
Single-Phase 220																
Single-Phase 230																
Single-Phase 230		50	0.32	56	400	42	300	1300	—							
Three-Phase 200																
Three-Phase 200										60	0.3	36	260	36	260	1550
Three-Phase 220																
Three-Phase 230		60	0.31	36	260	36	260	1600								
Three-Phase 230																

(TP) Contains a built-in thermal protector. If a motor overheats for any reason, the thermal protector is opened and the motor stops. When the motor temperature drops, the thermal protector closes and the motor restarts. Be sure to turn the motor off before inspecting.

• The "U" and "E" at the end of the model name indicate that the unit includes a capacitor. These two letters are not listed on the motor nameplate. When the motor is approved under various safety standards, the model name on the nameplate is the approved model name. →Page G-10

• Details of Safety Standard →Page G-2

\* The conduit box type of the motors are not VDE approved. The conduit box type does not have a specification for Single-Phase 220 VAC 50 Hz.

#### V Series (Quiet Operation, High Strength, Long Life)



Model		Output Power	Voltage	Frequency	Current	Starting Torque	Rated Torque	Rated Speed	Capacitor							
Combination Type		HP	W	VAC	Hz	A	oz-in	mN·m	oz-in	mN·m	r/min	μF				
Lead Wire Type Dimension ④	Terminal Box Type Dimension ⑤															
(TP) VHI540A-□U	VHI540AT-□U	1/19	40	Single-Phase 110		60	0.68	28	200	36	260	1500	9			
Single-Phase 115																
Single-Phase 220				50	0.39	28	200	36	260	1500	2.3					
Single-Phase 220																
Single-Phase 230																
Single-Phase 230		50	0.32	56	400	42	300	1300	—							
Three-Phase 200																
Three-Phase 200										60	0.3	36	260	36	260	1550
Three-Phase 220																
Three-Phase 230		60	0.31	36	260	36	260	1600								
Three-Phase 230																

(TP) Contains a built-in thermal protector. If a motor overheats for any reason, the thermal protector is opened and the motor stops. When the motor temperature drops, the thermal protector closes and the motor restarts. Be sure to turn the motor off before inspecting.

• The "U" and "E" at the end of the model name indicate that the unit includes a capacitor. These two letters are not listed on the motor nameplate. When the motor is approved under various safety standards, the model name on the nameplate is the approved model name. →Page G-11

• Details of Safety Standard →Page G-2

• Models above are provided as combination type with motor and gearhead pre-assembled.

• Enter gear ratio in the box (□) within the model name.

• The values in the table are for the motor only.

### Gearheads for World K Series (Sold Separately)

#### Parallel Shaft

Gearhead Model	Gear Ratio
5GN□KA	3~180
5GN10XK (Decimal Gearhead)	

• Enter the gear ratio in the box (□) within the model name.

#### Right-Angle

Type	Gearhead Model	Gear Ratio
Hollow Shaft	5GN□RH	3.6~180
Solid Shaft	5GN□RAA	3~180

• Enter the gear ratio in the box (□) within the model name.

• Right-Angle Gearheads →Page A-189

## ■ Gearmotor — Torque Table

### ● World K Series (General Purpose)

The maximum permissible torque with a decimal gearhead with a gear ratio of 10:1 is 88 lb-in (10 N·m).

#### ◆ Single-Phase 115/230 VAC 60 Hz, Three-Phase 230 VAC 60 Hz

Unit = Upper values: lb-in/Lower values: N·m

Model	Speed r/min	600	500	360	300	240	200	144	120	100	72	60	50	36	30	24	20	18	15	12	10
	Gear Ratio	3	3.6	5	6	7.5	9	12.5	15	18	25	30	36	50	60	75	90	100	120	150	180
5IK40GN-AWU 5IK40GN-AWTU 5IK40GN-CWE 5IK40GN-CWTE 5IK40GN-SW 5IK40GN-SWT 5IK40GN-FCH 5IK40GN-ECH 5IK40GN-SH	5GN□KA	5.5 0.63	6.7 0.76	9.7 1.1	11.5 1.3	14.1 1.6	16.8 1.9	23 2.6	28 3.2	33 3.8	41 4.7	50 5.7	60 6.8	76 8.6	88 10	88 10	88 10	88 10	88 10	88 10	88 10

#### ◆ Single-Phase 230 VAC 50 Hz

Unit = Upper values: lb-in/Lower values: N·m

Model	Speed r/min	500	416	300	250	200	166	120	100	83	60	50	41	30	25	20	16	15	12.5	10	8.3
	Gear Ratio	3	3.6	5	6	7.5	9	12.5	15	18	25	30	36	50	60	75	90	100	120	150	180
5IK40GN-CWE 5IK40GN-CWTE 5IK40GN-ECH	5GN□KA	6.4 0.73	7.6 0.87	10.6 1.2	13.2 1.5	15.9 1.8	19.4 2.2	26 3.0	31 3.6	38 4.4	48 5.5	58 6.6	69 7.9	87 9.9	88 10	88 10	88 10	88 10	88 10	88 10	88 10

### ● V Series (Quiet Operation, High Strength, Long Life)

#### ◆ Single-Phase 115/230 VAC 60 Hz, Three-Phase 230 VAC 60 Hz

Unit = Upper values: lb-in/Lower values: N·m

Model	Speed r/min	360	300	200	120	100	60	50	30	20	15	10	6
	Gear Ratio	5	6	9	15	18	30	36	60	90	120	180	300
VHI540A-□U VHI540AT-□U VHI540C-□E VHI540CT-□E VHI540S-□ VHI540ST-□		10.6 1.2	12.3 1.4	18.5 2.1	30 3.5	37 4.2	59 6.7	70 8	118 13.4	177 20.1	220 25.3	260 30	260 30

#### ◆ Single-Phase 230 VAC 50 Hz

Unit = Upper values: lb-in/Lower values: N·m

Model	Speed r/min	300	250	166	100	83	50	41	25	16	12.5	8.3	5
	Gear Ratio	5	6	9	15	18	30	36	60	90	120	180	300
VHI540C-□E VHI540CT-□E		12.3 1.4	14.1 1.6	21 2.4	36 4.1	43 4.9	68 7.7	82 9.3	137 15.5	200 23.2	250 29.2	260 30	260 30

- Gearheads and decimal gearheads are sold separately. Decimal gearheads are not available for V Series.
- Enter the gear ratio in the box (□) within the model name. A colored background indicates gear shaft rotation in the same direction as the motor shaft; a white background indicates rotation in the opposite direction.
- The speed is calculated by dividing the motor's synchronous speed (50 Hz: 1500 r/min, 60 Hz: 1800 r/min) by the gear ratio. The actual speed is 2~20% less than the displayed value, depending on the size of the load.

## ■ Gearmotor — Torque Table when Right-Angle Gearhead is Attached

Right-Angle Gearheads are available for the World K Series only.

→Page A-196

## ■ Permissible Overhung Load and Permissible Thrust Load

Motor (Round shaft type) →Page A-11

Gearhead →Page A-11

## ■ Permissible Load Inertia J for Gearhead

→Page A-12

## Dimensions Scale 1/4, Unit = inch (mm)

Mounting screws are included with gearheads. Dimensions for screws → A-223

### World K Series

#### Lead Wire Type

**Motor** / **Gearhead**

5IK40GN-AWU

5GN□KA

5IK40GN-CWE

5GN□KA

5IK40GN-SW

Weight: 5.5 lb. (2.5 kg) / Weight: 3.3 lb. (1.5 kg)

**DXF** A019AU (5GN3KA~18KA)  
A019BU (5GN25KA~180KA)

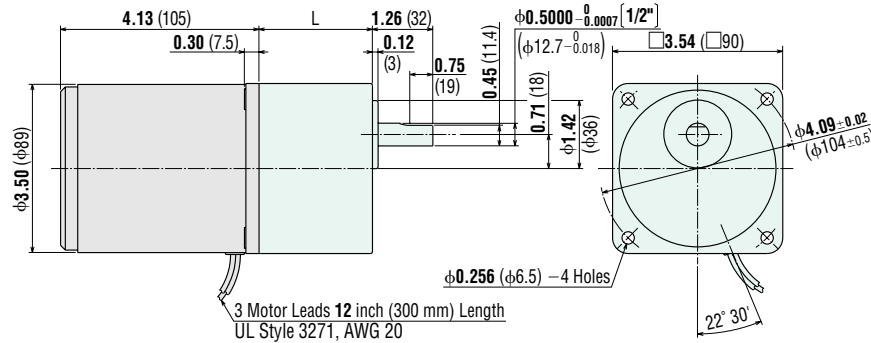

5GN3KA~18KA: L = 1.65 (42)

5GN25KA~180KA: L = 2.36 (60)

#### Terminal Box Type

**Motor** / **Gearhead**

5IK40GN-AWTU

5GN□KA

5IK40GN-CWTE

5GN□KA

5IK40GN-SWT

Weight: 5.7 lb. (2.6 kg) / Weight: 3.3 lb. (1.5 kg)

**DXF** A021AU (5GN3KA~18KA)  
A021BU (5GN25KA~180KA)

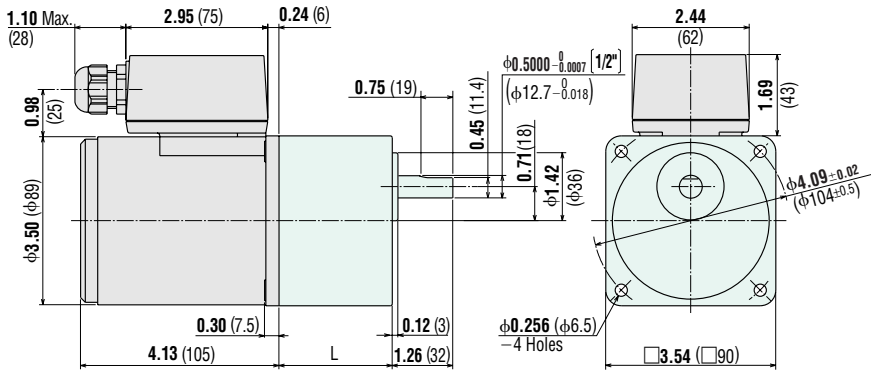

5GN3KA~18KA: L = 1.65 (42)

5GN25KA~180KA: L = 2.36 (60)

- Use cable (VCTF) with a diameter of  $\phi 0.24$  inch ( $\phi 6$  mm)~ $\phi 0.47$  inch ( $\phi 12$  mm).
- Details of Terminal Box → Page A-224

#### Round Shaft Type

5IK40A-AWU

5IK40A-CWE

5IK40A-SW

Weight: 5.5 lb. (2.5 kg)

**DXF** A329

3/8 inch shaft motors are also available. Contact your Oriental Motor Representative for more information.

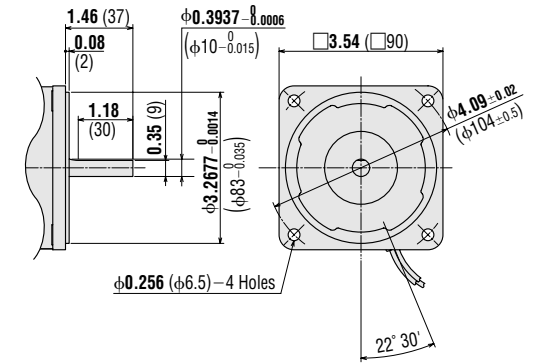

#### Round Shaft Type

5IK40A-AWTU

5IK40A-CWTE

5IK40A-SWT

Weight: 5.7 lb. (2.6 kg)

**DXF** A330

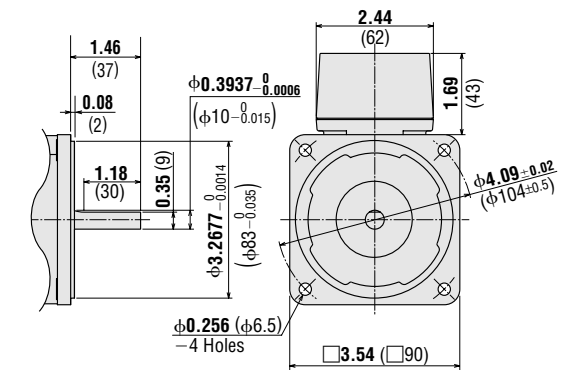



◆ Conduit Box Type

**Motor**  
**5IK40GN-FCH**  
**5IK40GN-ECH**  
 Weight: 5.9 lb. (2.7 kg)

**Gearhead**  
**5GN□KA**  
 Weight: 3.3 lb. (1.5 kg)

**DXF** A802A (5GN3KA~18KA)  
 A802B (5GN25KA~180KA)

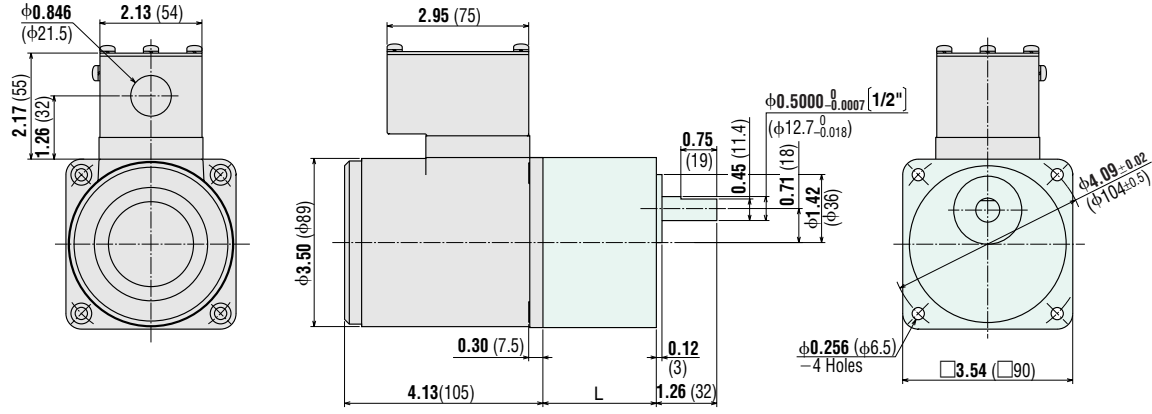

**5GN3KA~18KA:** L = 1.65 (42)  
**5GN25KA~180KA:** L = 2.36 (60)

3 Motor Leads: UL Style 3266, AWG 20  
 1 Ground Lead: UL Style 3266, AWG 18

●Details of Terminal Box → Page A-224

**Motor**  
**5IK40GN-SH**  
 Weight: 5.5 lb. (2.5 kg)

**Gearhead**  
**5GN□KA**  
 Weight: 3.3 lb. (1.5 kg)

**DXF** A803A (5GN3KA~18KA)  
 A803B (5GN25KA~180KA)

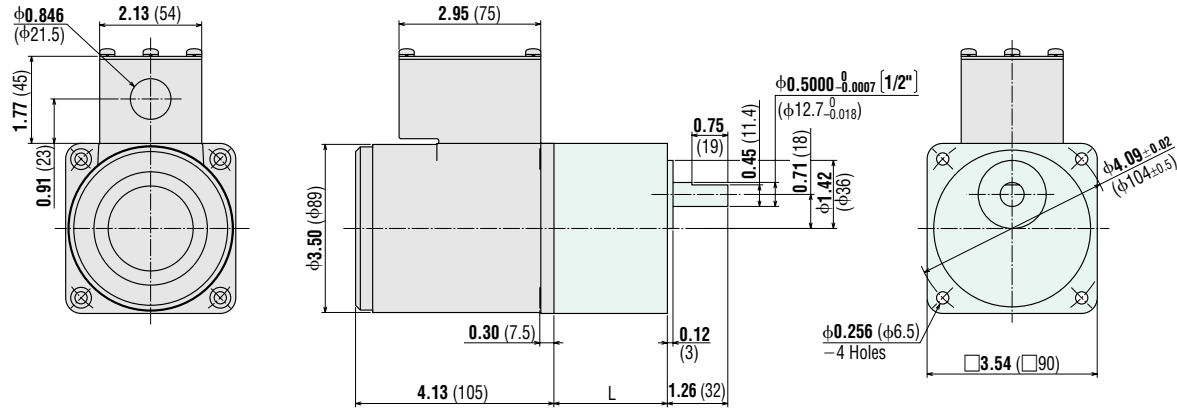

**5GN3KA~18KA:** L = 1.65 (42)  
**5GN25KA~180KA:** L = 2.36 (60)

3 Motor Leads: UL Style 3266, AWG 20  
 1 Ground Lead: UL Style 3266, AWG 18

●Details of Terminal Box → Page A-224

Round Shaft Type

**5IK40AA-FCH**  
**5IK40AA-ECH**  
 Weight: 5.9 lb. (2.7 kg)

**DXF** A811

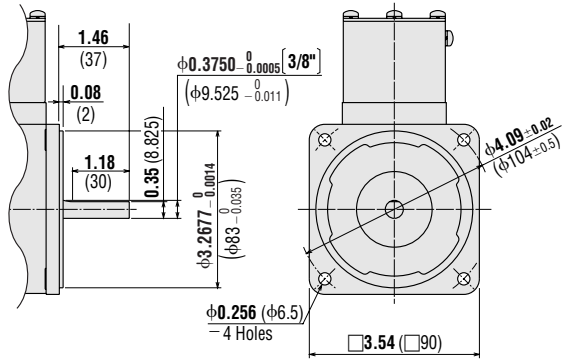

Round Shaft Type

**5IK40AA-SH**  
 Weight: 5.5 lb. (2.5 kg)

**DXF** A812

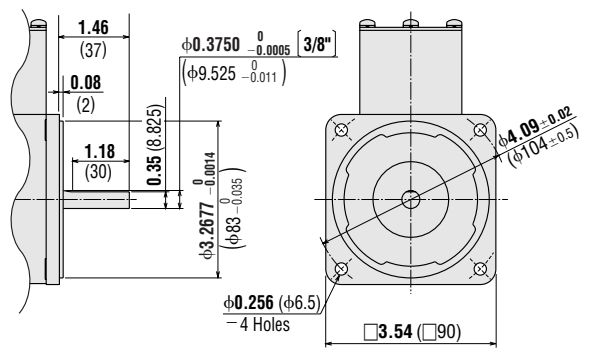

● **Decimal Gearhead (for World K Series)**

**5GN10XK** Weight: 1.3 lb. (0.6 kg)

**DXF** A022

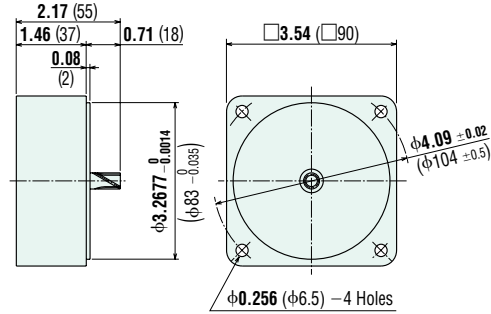

● **V Series**

◆ **Lead Wire Type**

**VHI540A-U, VHI540C-E, VHI540S-U**

Weight: 8.8 lb. (4.0 kg) including gearhead

Motor Model: VHI540A-GVH, VHI540C-GVH, VHI540S-GVH

Gearhead Model: GVH5G□

**DXF** A203A (GVH5G5~18)  
A203B (GVH5G30~90)  
A203C (GVH5G120~300)

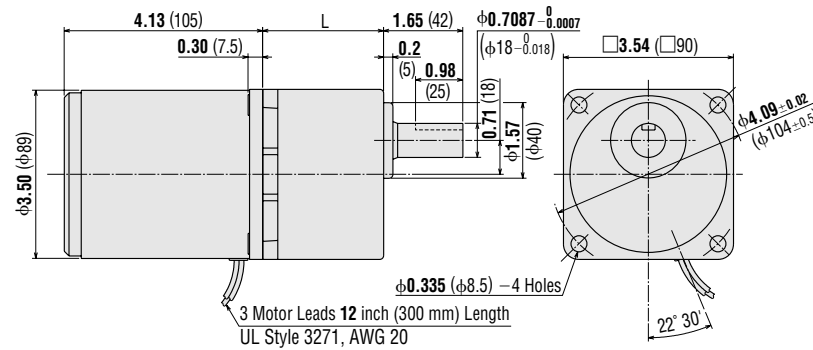

GVH5G5-GVH5G18: L = 1.77 (45)  
GVH5G30-GVH5G90: L = 2.28 (58)  
GVH5G120-GVH5G300: L = 2.52 (64)

◆ **Terminal Box Type**

**VHI540AT-U, VHI540CT-E, VHI540ST-U**

Weight: 9.0 lb. (4.1 kg) including gearhead

Motor Model: VHI540AT-GVH, VHI540CT-GVH, VHI540ST-GVH

Gearhead Model: GVH5G□

**DXF** A212A (GVH5G5~18)  
A212B (GVH5G30~90)  
A212C (GVH5G120~300)

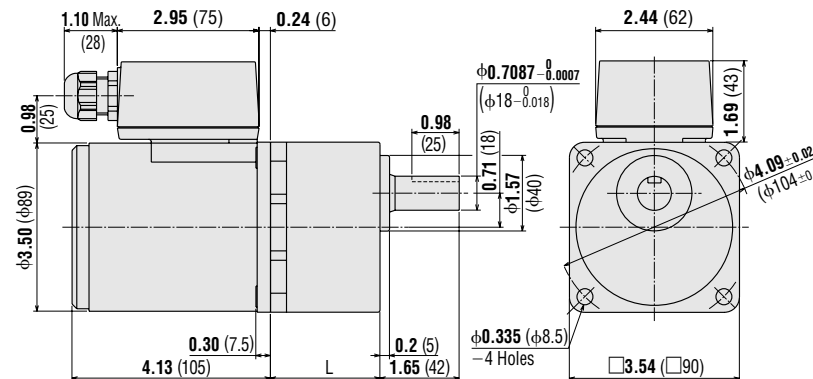

GVH5G5-GVH5G18: L = 1.77 (45)  
GVH5G30-GVH5G90: L = 2.28 (58)  
GVH5G120-GVH5G300: L = 2.52 (64)

- Use cable (VCTF) with a diameter of  $\phi 0.24$  inch ( $\phi 6$  mm)~ $\phi 0.47$  inch ( $\phi 12$  mm).
- Details of Terminal Box → Page A-224

● **Key and Key Slot (Scale 1/2)**

(The key is provided with the gearhead)

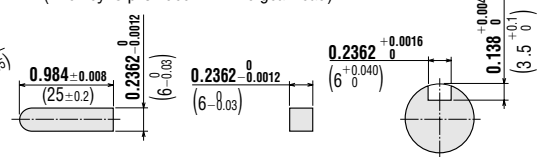

● **Key and Key Slot (Scale 1/2)**

(The key is provided with the gearhead)

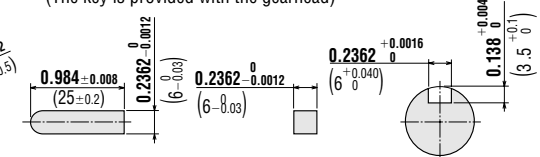

● **Capacitor** (included with single-phase motors)

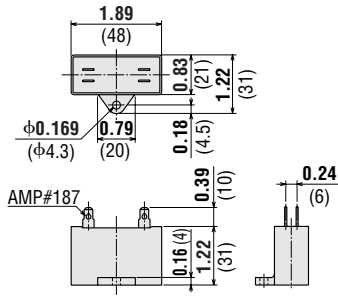

Motor Model	Capacitor Model	Weight oz. (g)
<b>51K40GN-AW(T)U</b> <b>51K40A-AW(T)U</b> <b>VH1540A-□U</b> <b>VH1540AT-□U</b>	CH90CFAUL	1.4 (40)
<b>51K40GN-CW(T)E</b> <b>51K40A-CW(T)E</b> <b>VH1540C-□E</b> <b>VH1540CT-□E</b>	CH23BFAUL	

- If you need to order a capacitor without a motor, add "-C" to the capacitor model name shown. A capacitor cap is included with a capacitor.

■ **Connection Diagrams**

Lead Wire Type	
<b>51K40GN-AWU</b> <b>51K40GN-CWE</b> <b>VH1540A-□U</b> <b>VH1540C-□E</b>	<b>51K40GN-SW</b> <b>VH1540S-□</b>
<p>To rotate the motor in a clockwise (CW) direction, flip switch SW to CW.</p> <p>To rotate it in a counterclockwise (CCW) direction, flip switch SW to CCW.</p>	<p>To change the rotation direction, change any two connections between U, V and W.</p>

Terminal Box Type	
<b>51K40GN-AWTU</b> <b>51K40GN-CWTE</b> <b>VH1540AT-□U</b> <b>VH1540CT-□E</b>	<b>51K40GN-SWT</b> <b>VH1540ST-□</b>
<p>To rotate the motor in a clockwise (CW) direction, flip switch SW to CW.</p> <p>To rotate it in a counterclockwise (CCW) direction, flip switch SW to CCW.</p>	<p>To change the rotation direction, change any two connections between U, V and W.</p>

Conduit Box Type	
<b>51K40GN-FCH</b> <b>51K40GN-ECH</b>	<b>51K40GN-SH</b>
<p>To rotate the motor in a clockwise (CW) direction, flip switch SW to CW.</p> <p>To rotate it in a counterclockwise (CCW) direction, flip switch SW to CCW.</p>	<p>To change the rotation direction, change any two connections between U, V and W.</p>

● **Inner Connection Diagram for 4-Terminal Capacitor**

Terminals of the capacitor are connected as shown in the figure. For lead wire connection, use one lead wire per terminal.

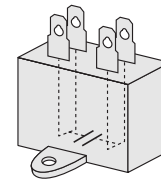

- The direction of motor rotation is as viewed from the shaft end of the motor.
- CW represents the clockwise direction, while CCW represents the counterclockwise direction.
- Connection diagrams are also valid for the equivalent round shaft type.
- **How to connect a capacitor** → Page A-225

**Note:**

- Change the direction of single-phase motor rotation only after bringing the motor to a stop. If an attempt is made to change the direction of rotation while the motor is rotating, the motor may ignore the reversing command or change its direction of rotation after some delay.

■ **List of Motor and Gearhead Combinations for V Series**

Model numbers for motor and gearhead combinations are shown below.

Model	Motor Model	Gearhead Model
<b>VH1540A-□U</b>	VH1540A-GVH	GVH5G□
<b>VH1540C-□E</b>	VH1540C-GVH	
<b>VH1540S-□</b>	VH1540S-GVH	
<b>VH1540AT-□U</b>	VH1540AT-GVH	
<b>VH1540CT-□E</b>	VH1540CT-GVH	
<b>VH1540ST-□</b>	VH1540ST-GVH	

- Enter the gear ratio in the box (□) within the model name.

# Induction Motors

## 60 W (1/12 HP)

Frame Size: □ 3.54 in. (□ 90 mm)



World **K** Series  
(Gearhead Sold Separately)



**V** Series/Combination Type  
(Pre-assembled Gearmotor)

### Specifications — Continuous Rating

#### World K Series (General Purpose)



Model			Output Power	Voltage	Frequency	Current	Starting Torque	Rated Torque	Rated Speed	Capacitor				
Upper Model Name: Pinion Shaft Type Lower Model Name( ): Round Shaft Type														
Lead Wire Type Dimension ①	Terminal Box Type Dimension ②	Conduit Box Type Dimension ③	HP	W	VAC	Hz	A	oz-in	mN·m	oz-in	mN·m	r/min	μF	
ⓉP	5IK60GU-AWU (5IK60A-AWU)	5IK60GU-AWTU (5IK60A-AWTU)	5IK60GU-FCH (5IK60A-FCH)	1/12	60	Single-Phase 110	60	1.09	45	320	57	405	1450	18
						Single-Phase 115	60	1.10						
ⓉP	5IK60GU-CWE (5IK60A-CWE)	5IK60GU-CWTE (5IK60A-CWTE)	5IK60GU-ECH* (5IK60A-ECH)*	1/12	60	Single-Phase 220*	50	0.55	45	320	57	405	1450	4
						Single-Phase 220	60	0.54						
						Single-Phase 230	50	0.57	57	405	1450			
						Single-Phase 230	60	0.54						
						ⓉP	5IK60GU-SW (5IK60A-SW)	5IK60GU-SWT (5IK60A-SWT)	5IK60GU-SH (5IK60A-SH)	1/12	60	Three-Phase 200	50	0.50
Three-Phase 200	60	0.43	71	500	53							380	1550	
Three-Phase 220	60	0.45	71	500	53							380	1600	
						Three-Phase 230	60	0.46	71	500	53	380	1600	

ⓉP Contains a built-in thermal protector. If a motor overheats for any reason, the thermal protector is opened and the motor stops. When the motor temperature drops, the thermal protector closes and the motor restarts. Be sure to turn the motor off before inspecting.

• The "U" and "E" at the end of the model name indicate that the unit includes a capacitor. These two letters are not listed on the motor nameplate.

When the motor is approved under various safety standards, the model name on the nameplate is the approved model name. →Page G-10

• Details of Safety Standard →Page G-2

\* The conduit box type motors are not VDE approved. The conduit box type does not have a specification for Single-Phase 220 VAC 50 Hz.

#### V Series (Quiet Operation, High Strength, Long Life)



Model		Output Power	Voltage	Frequency	Current	Starting Torque	Rated Torque	Rated Speed	Capacitor					
Combination Type														
Lead Wire Type Dimension ④	Terminal Box Type Dimension ⑤	HP	W	VAC	Hz	A	oz-in	mN·m	oz-in	mN·m	r/min	μF		
ⓉP	VHI560A-□U	VHI560AT-□U	1/12	60	Single-Phase 110	60	1.09	45	320	57	405	1450	18	
					Single-Phase 115	60	1.10							
ⓉP	VHI560C-□E	VHI560CT-□E	1/12	60	Single-Phase 220	50	0.55	45	320	57	405	1450	4	
					Single-Phase 220	60	0.54							
					Single-Phase 230	50	0.57	57	405	1450				
					Single-Phase 230	60	0.54							
					ⓉP	VHI560S-□	VHI560ST-□	1/12	60	Three-Phase 200	50	0.50	85	600
Three-Phase 200	60	0.43	71	500						53	380	1550		
Three-Phase 220	60	0.45	71	500						53	380	1600		
						Three-Phase 230	60	0.46	71	500	53	380	1600	

ⓉP Contains a built-in thermal protector. If a motor overheats for any reason, the thermal protector is opened and the motor stops. When the motor temperature drops, the thermal protector closes and the motor restarts. Be sure to turn the motor off before inspecting.

• The "U" and "E" at the end of the model name indicate that the unit includes a capacitor. These two letters are not listed on the motor nameplate.

When the motor is approved under various safety standards, the model name on the nameplate is the approved model name. →Page G-11

• Details of Safety Standard →Page G-2

• Models above are provided as combination type with motor and gearhead pre-assembled.

• Enter gear ratio in the box (□) within the model name.

• The values in the table are for the motor only.

### Gearheads for World K Series (Sold Separately)

#### Parallel Shaft

Gearhead Model	Gear Ratio
5GU□KA	3~180
5GU10XKB (Decimal Gearhead)	

• Enter the gear ratio in the box (□) within the model name.

#### Right-Angle

Type	Gearhead Model	Gear Ratio
Hollow Shaft	5GU□RH	3.6~180
Solid Shaft	5GU□RAA	3~180

• Enter the gear ratio in the box (□) within the model name.

• Right-Angle Gearheads →Page A-189

## ■ Gearmotor — Torque Table

### ● World K Series (General Purpose)

The maximum permissible torque with a decimal gearhead with a gear ratio of 10:1 is 177 lb-in (20 N·m).

#### ◆ Single-Phase 115/230 VAC 60 Hz, Three-Phase 230 VAC 60 Hz

Unit = Upper values: lb-in/Lower values: N·m

Model	Speed r/min	600	500	360	300	240	200	144	120	100	72	60	50	36	30	24	20	18	15	12	10	
	Gear Ratio	<b>3</b>	<b>3.6</b>	<b>5</b>	<b>6</b>	<b>7.5</b>	<b>9</b>	<b>12.5</b>	<b>15</b>	<b>18</b>	<b>25</b>	<b>30</b>	<b>36</b>	<b>50</b>	<b>60</b>	<b>75</b>	<b>90</b>	<b>100</b>	<b>120</b>	<b>150</b>	<b>180</b>	
5IK60GU-AWU 5IK60GU-AWTU 5IK60GU-CWE 5IK60GU-CWTE 5IK60GU-FCH 5IK60GU-ECH	5GU□KA	8.6 0.98	10.6 1.2	14.1 1.6	17.7 2.0	22 2.5	26 3.0	32 3.7	38 4.4	46 5.3	59 6.7	70 8.0	84 9.6	118 13.4	141 16.0	158 17.9	177 20	177 20	177 20	177 20	177 20	177 20
	5IK60GU-SW 5IK60GU-SWT 5IK60GU-SH	5GU□KA	8.1 0.92	9.7 1.1	13.2 1.5	15.9 1.8	20 2.3	24 2.8	30 3.5	37 4.2	44 5.0	55 6.3	66 7.5	79 9.0	110 12.5	132 15.0	148 16.8	177 20	177 20	177 20	177 20	177 20

#### ◆ Single-Phase 230 VAC 50 Hz

Unit = Upper values: lb-in/Lower values: N·m

Model	Speed r/min	500	416	300	250	200	166	120	100	83	60	50	41	30	25	20	16	15	12.5	10	8.3
	Gear Ratio	<b>3</b>	<b>3.6</b>	<b>5</b>	<b>6</b>	<b>7.5</b>	<b>9</b>	<b>12.5</b>	<b>15</b>	<b>18</b>	<b>25</b>	<b>30</b>	<b>36</b>	<b>50</b>	<b>60</b>	<b>75</b>	<b>90</b>	<b>100</b>	<b>120</b>	<b>150</b>	<b>180</b>
5IK60GU-CWE 5IK60GU-CWTE 5IK60GU-ECH	5GU□KA	10.6 1.2	12.3 1.4	17.7 2.0	21 2.4	26 3.0	31 3.6	39 4.5	47 5.4	56 6.4	71 8.1	85 9.7	102 12	143 16	171 19	177 20	177 20	177 20	177 20	177 20	177 20

### ● V Series (Quiet Operation, High Strength, Long Life)

#### ◆ Single-Phase 115/230 VAC 60 Hz, Three-Phase 230 VAC 60 Hz

Unit = Upper values: lb-in/Lower values: N·m

Model	Speed r/min	360	300	200	120	100	60	50	30	20	15	10	6
	Gear Ratio	<b>5</b>	<b>6</b>	<b>9</b>	<b>15</b>	<b>18</b>	<b>30</b>	<b>36</b>	<b>60</b>	<b>90</b>	<b>120</b>	<b>180</b>	<b>300</b>
VHI560A-□U VHI560AT-□U VHI560C-□E VHI560CT-□E		15.9 1.8	19.4 2.2	29 3.3	48 5.5	58 6.6	92 10.4	110 12.5	184 20.9	260 30	260 30	260 30	260 30
VHI560S-□ VHI560ST-□		15 1.7	18.5 2.1	27 3.1	45 5.1	54 6.2	86 9.8	104 11.8	173 19.6	260 29.4	260 30	260 30	260 30

#### ◆ Single-Phase 230 VAC 50 Hz

Unit = Upper values: lb-in/Lower values: N·m

Model	Speed r/min	300	250	166	100	83	50	41	25	16	12.5	8.3	5
	Gear Ratio	<b>5</b>	<b>6</b>	<b>9</b>	<b>15</b>	<b>18</b>	<b>30</b>	<b>36</b>	<b>60</b>	<b>90</b>	<b>120</b>	<b>180</b>	<b>300</b>
VHI560C-□E VHI560CT-□E		19.4 2.2	23 2.6	35 4	58 6.6	69 7.9	111 12.6	134 15.2	230 26.3	260 30	260 30	260 30	260 30

● Gearheads and decimal gearheads are sold separately. Decimal gearheads are not available for V Series.

● Enter the gear ratio in the box (□) within the model name. A colored background indicates gear shaft rotation in the same direction as the motor shaft; a white background indicates rotation in the opposite direction.

● The speed is calculated by dividing the motor's synchronous speed (50 Hz: 1500 r/min, 60 Hz: 1800 r/min) by the gear ratio. The actual speed is 2~20% less than the displayed value, depending on the size of the load.

## ■ Gearmotor — Torque Table when Right-Angle Gearhead is Attached

Right-Angle Gearheads are available for the World K Series only.

→Page A-196

## ■ Permissible Overhung Load and Permissible Thrust Load

Motor (Round shaft type) →Page A-11

Gearhead →Page A-11

## ■ Permissible Load Inertia J for Gearhead

→Page A-12

## Dimensions Scale 1/4, Unit = inch (mm)

Mounting screws are included with gearheads. Dimensions for screws → A-223

### World K Series

#### Lead Wire Type

Motor / Gearhead

51K60GU-AWU

5GU□KA

51K60GU-CWE

51K60GU-SW

Weight: 5.9 lb. (2.7 kg)

Weight: 3.3 lb. (1.5 kg)

DXF A026U (5GU3KA~180KA)

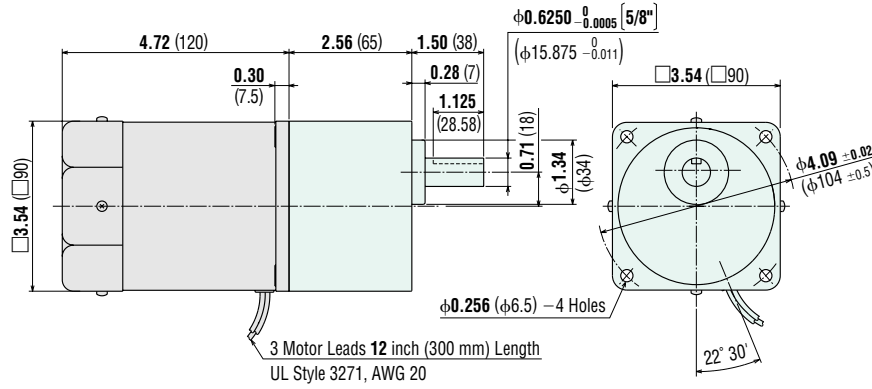

#### Key and Key Slot (Scale 1/2)

(The key is provided with the gearhead)

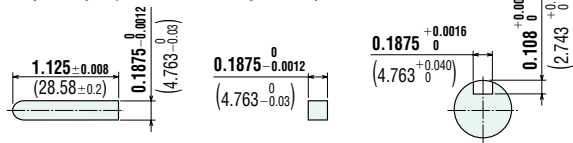

#### Terminal Box Type

Motor / Gearhead

51K60GU-AWTU

5GU□KA

51K60GU-CWTE

51K60GU-SWT

Weight: 6.2 lb. (2.8 kg)

Weight: 3.3 lb. (1.5 kg)

DXF A027U (5GU3KA~180KA)

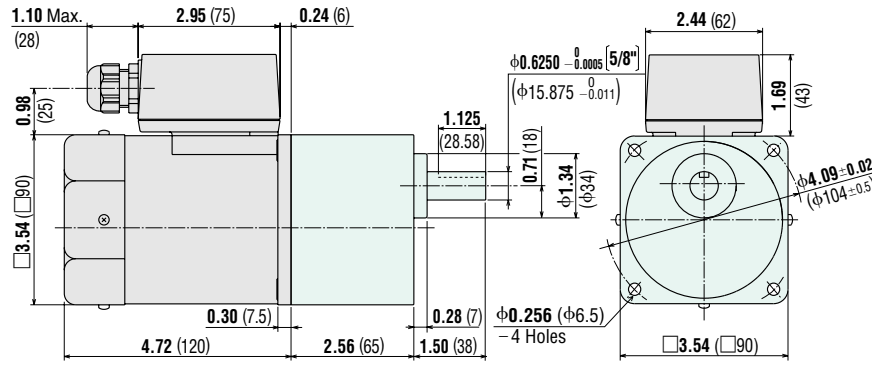

● Use cable (VCTF) with a diameter of  $\phi 0.24$  inch ( $\phi 6$  mm) ~  $\phi 0.47$  inch ( $\phi 12$  mm).

● Details of Terminal Box → Page A-224

#### Key and Key Slot (Scale 1/2)

(The key is provided with the gearhead)

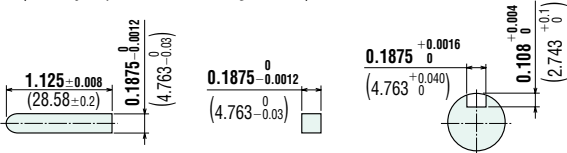

#### Round Shaft Type

51K60A-AWU

51K60A-CWE

51K60A-SW

Weight: 5.9 lb. (2.7 kg)

DXF A331

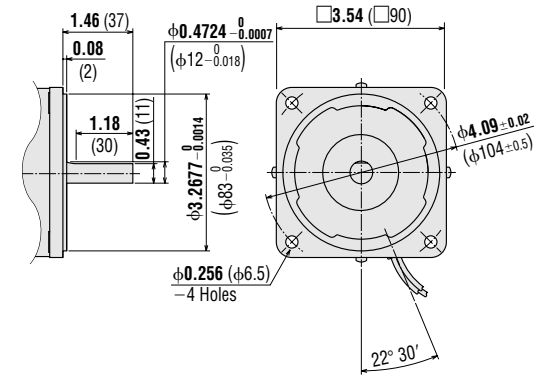

#### Round Shaft Type

51K60A-AWTU

51K60A-CWTE

51K60A-SWT

Weight: 6.2 lb. (2.8 kg)

DXF A332

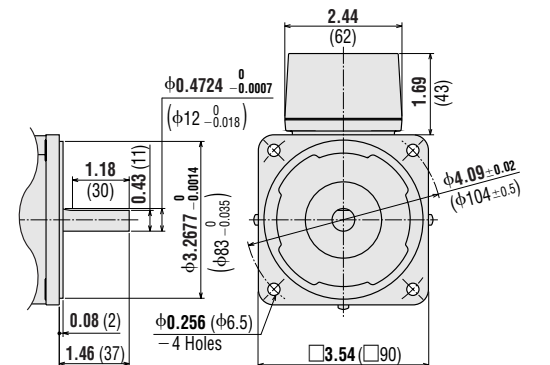

◆ Conduit Box Type

Motor  
**5IK60GU-FCH**  
**5IK60GU-ECH**

Weight: 7.0 lb. (3.2 kg)

Gearhead

**5GU□KA**

Weight: 3.3 lb. (1.5 kg)

DXF A804 (5GU3KA~180KA)

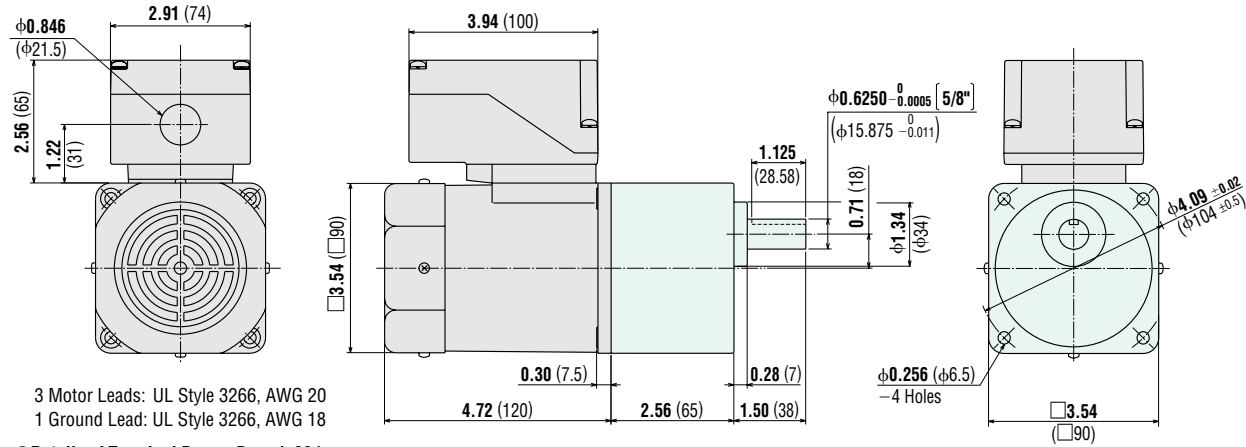

3 Motor Leads: UL Style 3266, AWG 20  
 1 Ground Lead: UL Style 3266, AWG 18

●Details of Terminal Box → Page A-224

●Key and Key Slot (Scale 1/2)

(The key is provided with the gearhead)

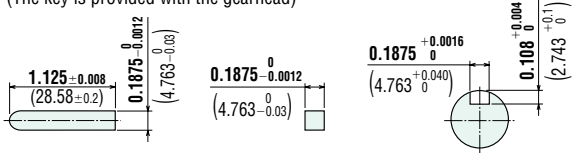

Motor  
**5IK60GU-SH**

Weight: 6.2 lb. (2.8 kg)

Gearhead

**5GU□KA**

Weight: 3.3 lb. (1.5 kg)

DXF A805 (5GU3KA~180KA)

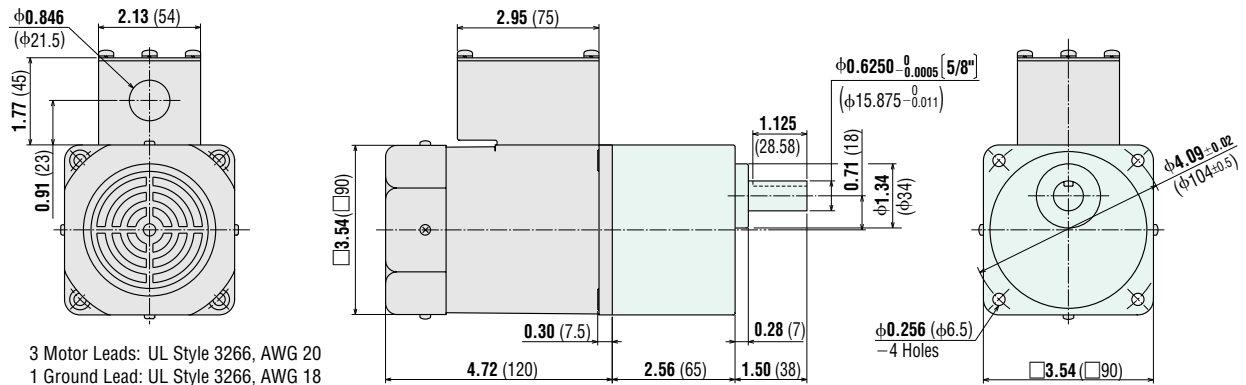

3 Motor Leads: UL Style 3266, AWG 20  
 1 Ground Lead: UL Style 3266, AWG 18

●Details of Terminal Box → Page A-224

●Key and Key Slot (Scale 1/2)

(The key is provided with the gearhead)

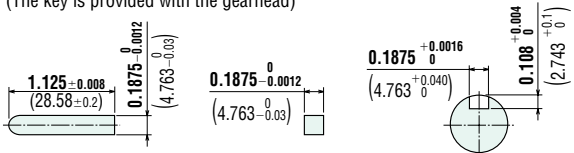

**Round Shaft Type**

**51K60A-FCH**  
**51K60A-ECH**

Weight: 7.0 lb. (3.2 kg)

**DXF** A813

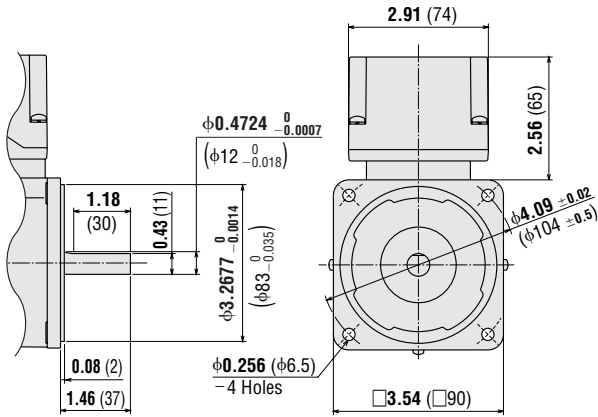

● Details of Terminal Box → Page A-224

**Round Shaft Type**

**51K60A-SH**

Weight: 6.2 lb. (2.8 kg)

**DXF** A814

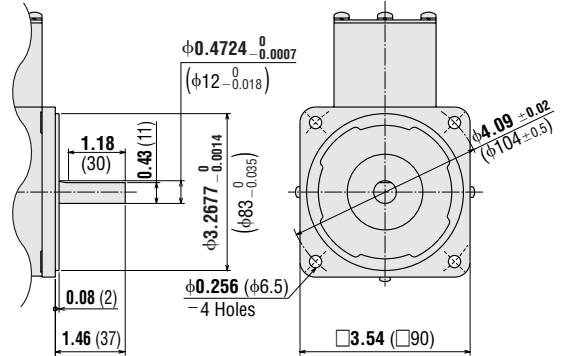

**Decimal Gearhead (for World K Series)**

**5GU10XKB** Weight: 1.3 lb. (0.6 kg)

**DXF** A029

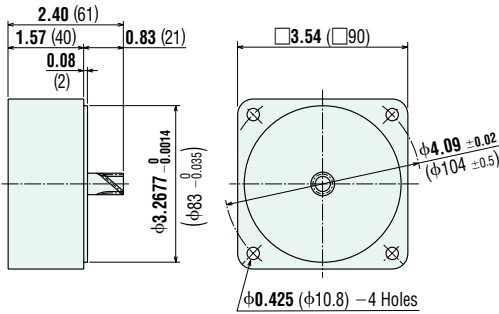

**V Series**

**◆ Lead Wire Type**

**VH1560A-□U, VH1560C-□E, VH1560S-□** (Combination Type)

Weight: 9.2 lb. (4.2 kg) including gearhead

Motor Model: VH1560A-GVH, VH1560C-GVH, VH1560S-GVH

Gearhead Model: GVH5G□

**DXF** A244A (GVH5G5~18)  
A244B (GVH5G30~90)  
A244C (GVH5G120~300)

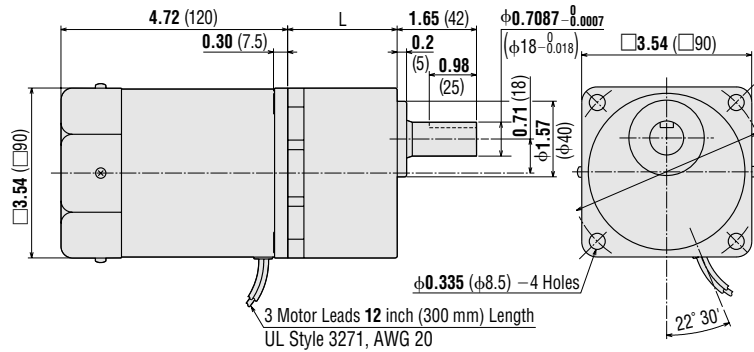

GVH5G5-GVH5G18: L = 1.77 (45)  
GVH5G30-GVH5G90: L = 2.28 (58)  
GVH5G120-GVH5G300: L = 2.52 (64)

**● Key and Key Slot (Scale 1/2)**

(The key is provided with the gearhead)

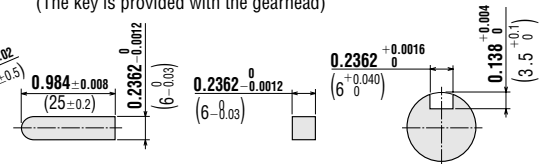



◆ Terminal Box Type

VH1560AT-□U, VH1560CT-□E, VH1560ST-□ (Combination Type)

Weight: 9.5 lb. (4.3 kg) including gearhead

Motor Model: VH1560AT-GVH, VH1560CT-GVH, VH1560ST-GVH

Gearhead Model: GVH5G□

- DXF A245A (GVH5G5~18)
- A245B (GVH5G30~90)
- A245C (GVH5G120~300)

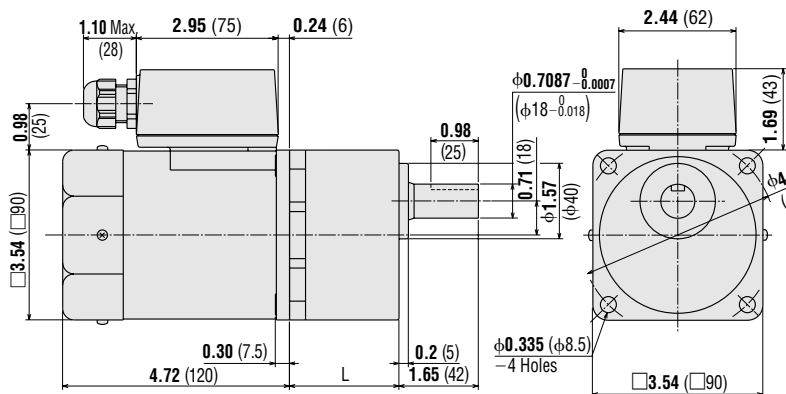

● Key and Key Slot (Scale 1/2)

(The key is provided with the gearhead)

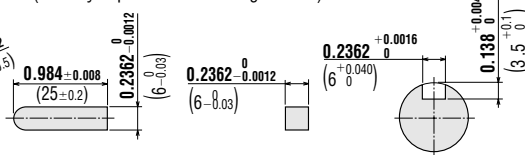

- GVH5G5~GVH5G18: L = 1.77 (45)
- GVH5G30~GVH5G90: L = 2.28 (58)
- GVH5G120~GVH5G300: L = 2.52 (64)

● Use cable (VCTF) with a diameter of  $\phi 0.24$  inch ( $\phi 6$  mm)~ $\phi 0.47$  inch ( $\phi 12$  mm).

● Details of Terminal Box → Page A-224

● Capacitor (included with single-phase motors)

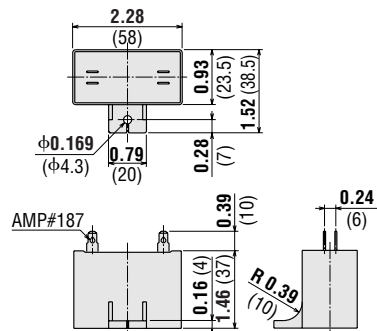

Motor Model	Capacitor Model	Weight oz. (g)
5IK60GU-AW(T)U 5IK60A-AW(T)U VH1560A-□U VH1560AT-□U	CH180CFAUL	2.5 (70)
5IK60GU-CW(T)E 5IK60A-CW(T)E VH1560C-□E VH1560CT-□E	CH40BFAUL	

● If you need to order a capacitor without a motor, add "-C" to the capacitor model name shown. A capacitor cap is included with a capacitor.

Introduction

Induction Motors

Reversible Motors

Synchronous Motors

Torque Motors

Waterlight Motors

Magnetic Brake

Clutch & Brake

Brake Pack

Right-Angle Gearheads

Accessories

Before Using a Standard AC Motor

## Connection Diagrams

Lead Wire Type	
<p><b>51K60GU-AWU</b> <b>51K60GU-CWE</b> <b>VH1560A-□U</b> <b>VH1560C-□E</b></p> <p>To rotate the motor in a clockwise (CW) direction, flip switch SW to CW. To rotate it in a counterclockwise (CCW) direction, flip switch SW to CCW.</p>	<p><b>51K60GU-SW</b> <b>VH1560S-□</b></p> <p>To change the rotation direction, change any two connections between U, V and W.</p>

Terminal Box Type	
<p><b>51K60GU-AWTU</b> <b>51K60GU-CWTE</b> <b>VH1560AT-□U</b> <b>VH1560CT-□E</b></p> <p>To rotate the motor in a clockwise (CW) direction, flip switch SW to CW. To rotate it in a counterclockwise (CCW) direction, flip switch SW to CCW.</p>	<p><b>51K60GU-SWT</b> <b>VH1560ST-□</b></p> <p>To change the rotation direction, change any two connections between U, V and W.</p>

Conduit Box Type	
<p><b>51K60GU-FCH</b> <b>51K60GU-ECH</b></p> <p>To rotate the motor in a clockwise (CW) direction, flip switch SW to CW. To rotate it in a counterclockwise (CCW) direction, flip switch SW to CCW.</p>	<p><b>51K60GU-SH</b></p> <p>To change the rotation direction, change any two connections between U, V and W.</p>

### Inner Connection Diagram for 4-Terminal Capacitor

Terminals of the capacitor are connected as shown in the figure. For lead wire connection, use one lead wire per terminal.

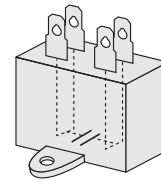

- The direction of motor rotation is as viewed from the shaft end of the motor.
- CW represents the clockwise direction, while CCW represents the counterclockwise direction.
- Connection diagrams are also valid for the equivalent round shaft type.
- **How to connect a capacitor** → Page A-225

**Note:**

- Change the direction of single-phase motor rotation only after bringing the motor to a stop. If an attempt is made to change the direction of rotation while the motor is rotating, the motor may ignore the reversing command or change its direction of rotation after some delay.

## List of Motor and Gearhead Combinations for V Series

Model numbers for motor and gearhead combinations are shown below.

Model	Motor Model	Gearhead Model
<b>VH1560A-□U</b>	VH1560A-GVH	GVH5G□
<b>VH1560C-□E</b>	VH1560C-GVH	
<b>VH1560S-□</b>	VH1560S-GVH	
<b>VH1560AT-□U</b>	VH1560AT-GVH	
<b>VH1560CT-□E</b>	VH1560CT-GVH	
<b>VH1560ST-□</b>	VH1560ST-GVH	

- Enter the gear ratio in the box (□) within the model name.

## Induction Motors

# 90 W (1/8 HP)

Frame Size: □ 3.54 in. (□ 90 mm)



World **K** Series  
(Gearhead Sold Separately)



**V** Series/Combination Type  
(Pre-assembled Gearmotor)



### Specifications — Continuous Rating

#### World K Series (General Purpose)

Model			Output Power	Voltage	Frequency	Current	Starting Torque	Rated Torque	Rated Speed	Capacitor			
Upper Model Name: Pinion Shaft Type	Lower Model Name(): Round Shaft Type												
Lead Wire Type	Terminal Box Type	Conduit Box Type	HP	W	VAC	Hz	A	oz-in	mN·m	oz-in	mN·m	r/min	μF
Dimension ①	Dimension ②	Dimension ③											
TP 51K90GU-AWU (51K90A-AWU)	51K90GU-AWTU (51K90A-AWTU)	51K90GU-FCH (51K90A-FCH)	1/8	90	Single-Phase 110	60	1.45	63	450	83	585	1500	20
					Single-Phase 115	60	1.44						
TP 51K90GU-CWE (51K90A-CWE)	51K90GU-CWTE (51K90A-CWTE)	51K90GU-ECH* (51K90A-ECH)*	1/8	90	Single-Phase 220*	50	0.74	63	450	103	730	1200	6
					Single-Phase 220	60	0.82						
					Single-Phase 230	50	0.76						
					Single-Phase 230	60	0.81						
TP 51K90GU-SW (51K90A-SW)	51K90GU-SWT (51K90A-SWT)	51K90GU-SH (51K90A-SH)	1/8	90	Three-Phase 200	50	0.64	99	700	80	570	1300	—
					Three-Phase 200	60	0.59						
					Three-Phase 220	60	0.60						
					Three-Phase 230	60	0.61	99	700	80	570	1600	

TP Contains a built-in thermal protector. If a motor overheats for any reason, the thermal protector is opened and the motor stops. When the motor temperature drops, the thermal protector closes and the motor restarts. Be sure to turn the motor off before inspecting.

The "U" and "E" at the end of the model name indicate that the unit includes a capacitor. These two letters are not listed on the motor nameplate. When the motor is approved under various safety standards, the model name on the nameplate is the approved model name. →Page G-10

Details of Safety Standard →Page G-2

\* The conduit box type of the motors are not VDE approved. The conduit box type does not have a specification for Single-Phase 220 VAC 50 Hz.

#### V Series (Quiet Operation, High Strength, Long Life)



Model			Output Power	Voltage	Frequency	Current	Starting Torque	Rated Torque	Rated Speed	Capacitor			
Combination Type													
Lead Wire Type	Terminal Box Type		HP	W	VAC	Hz	A	oz-in	mN·m	oz-in	mN·m	r/min	μF
Dimension ④	Dimension ⑤												
TP VH1590A-□U	VH1590AT-□U		1/8	90	Single-Phase 110	60	1.56	63	450	83	585	1500	25
					Single-Phase 115	60	1.55						
TP VH1590C-□E	VH1590CT-□E		1/8	90	Single-Phase 220	50	0.74	63	450	103	730	1200	6
					Single-Phase 220	60	0.82						
					Single-Phase 230	50	0.76						
					Single-Phase 230	60	0.81						
TP VH1590S-□	VH1590ST-□		1/8	90	Three-Phase 200	50	0.64	99	700	80	570	1300	—
					Three-Phase 200	60	0.59						
					Three-Phase 220	60	0.60						
					Three-Phase 230	60	0.61	99	700	80	570	1600	

TP Contains a built-in thermal protector. If a motor overheats for any reason, the thermal protector is opened and the motor stops. When the motor temperature drops, the thermal protector closes and the motor restarts. Be sure to turn the motor off before inspecting.

The "U" and "E" at the end of the model name indicate that the unit includes a capacitor. These two letters are not listed on the motor nameplate. When the motor is approved under various safety standards, the model name on the nameplate is the approved model name. →Page G-11

Details of Safety Standard →Page G-2

Models above are provided as combination type with motor and gearhead pre-assembled.

Enter gear ratio in the box (□) within the model name.

The values in the table are for the motor only.

### Gearheads for World K Series (Sold Separately)

#### Parallel Shaft

Gearhead Model	Gear Ratio
5GU□KA	3~180
5GU□KHA (High Power Type)	50~180
5GU10XKB (Decimal Gearhead) [for 5GU□KA]	
5GU10XK (Decimal Gearhead) [for 5GU□KHA]	

Enter the gear ratio in the box (□) within the model name.

#### Right-Angle

Type	Gearhead Model	Gear Ratio
Hollow Shaft	5GU□RH	3.6~180
Solid Shaft	5GU□RAA	3~180

Enter the gear ratio in the box (□) within the model name.

Right-Angle Gearheads →Page A-189

## ■ Gearmotor — Torque Table

### ● World K Series (General Purpose)

The maximum permissible torque when a decimal gearhead with a gear ratio of 10:1 is:

**5GU□KA:** 177 lb-in (20 N·m)

**5GU□KHA:** 260 lb-in (30 N·m)

#### ◆ Single-Phase 115/230 VAC 60 Hz, Three-Phase 230 VAC 60 Hz

Unit = Upper values: lb-in/Lower values: N·m

Model	Speed r/min Gear Ratio	600	500	360	300	240	200	144	120	100	72	60	50	36	30	24	20	18	15	12	10
		<b>3</b>	<b>3.6</b>	<b>5</b>	<b>6</b>	<b>7.5</b>	<b>9</b>	<b>12.5</b>	<b>15</b>	<b>18</b>	<b>25</b>	<b>30</b>	<b>36</b>	<b>50</b>	<b>60</b>	<b>75</b>	<b>90</b>	<b>100</b>	<b>120</b>	<b>150</b>	<b>180</b>
5IK90GU-AWU 5IK90GU-AWTU 5IK90GU-FCH	5GU□KA	12.3 1.4	15 1.7	21 2.4	24 2.8	31 3.6	38 4.3	46 5.3	56 6.4	68 7.7	85 9.7	102 11.6	123 13.9	170 19.3	177 20	177 20	177 20	177 20	177 20	177 20	177 20
	5GU□KHA	—	—	—	—	—	—	—	—	—	—	—	—	170 19.3	200 23.2	220 25.9	260 30	260 30	260 30	260 30	260 30
5IK90GU-CWE 5IK90GU-CWTE 5IK90GU-ECH	5GU□KA	13.2 1.5	15.9 1.8	22 2.5	25 2.9	32 3.7	38 4.4	48 5.5	58 6.6	69 7.9	88 10.0	106 12.0	127 14.4	177 20	177 20	177 20	177 20	177 20	177 20	177 20	177 20
	5GU□KHA	—	—	—	—	—	—	—	—	—	—	—	—	177 20	210 24	230 26.8	260 30	260 30	260 30	260 30	260 30
5IK90GU-SW 5IK90GU-SWT 5IK90GU-SH	5GU□KA	12.3 1.4	15 1.7	20 2.3	24 2.8	30 3.5	37 4.2	46 5.2	54 6.2	66 7.5	83 9.4	100 11.3	119 13.5	166 18.8	177 20	177 20	177 20	177 20	177 20	177 20	177 20
	5GU□KHA	—	—	—	—	—	—	—	—	—	—	—	—	166 18.8	200 22.6	220 25.2	260 30	260 30	260 30	260 30	260 30

● KA type is standard gearhead. KHA type is high-powered gearhead.

#### ◆ Single-Phase 230 VAC 50 Hz

Unit = Upper values: lb-in/Lower values: N·m

Model	Speed r/min Gear Ratio	500	416	300	250	200	166	120	100	83	60	50	41	30	25	20	16	15	12.5	10	8.3
		<b>3</b>	<b>3.6</b>	<b>5</b>	<b>6</b>	<b>7.5</b>	<b>9</b>	<b>12.5</b>	<b>15</b>	<b>18</b>	<b>25</b>	<b>30</b>	<b>36</b>	<b>50</b>	<b>60</b>	<b>75</b>	<b>90</b>	<b>100</b>	<b>120</b>	<b>150</b>	<b>180</b>
5IK90GU-CWE 5IK90GU-CWTE 5IK90GU-ECH	5GU□KA	15.9 1.8	18.5 2.1	26 3.0	30 3.5	38 4.4	46 5.3	59 6.7	70 8.0	84 9.6	106 12.0	128 14.5	153 17.3	177 20	177 20	177 20	177 20	177 20	177 20	177 20	177 20
	5GU□KHA	—	—	—	—	—	—	—	—	—	—	—	—	210 24.1	250 28.9	260 30	260 30	260 30	260 30	260 30	260 30

● KA type is standard gearhead. KHA type is high-powered gearhead.

### ● V Series (Quiet Operation, High Strength, Long Life)

#### ◆ Single-Phase 115/230 VAC 60 Hz, Three-Phase 230 VAC 60 Hz

Unit = Upper values: lb-in/Lower values: N·m

Model	Speed r/min Gear Ratio	360	300	200	120	100	60	50	30	20	15	10
		<b>5</b>	<b>6</b>	<b>9</b>	<b>15</b>	<b>18</b>	<b>30</b>	<b>36</b>	<b>60</b>	<b>90</b>	<b>120</b>	<b>180</b>
VHI590A-□U VHI590AT-□U	23	28	41	69	80	133	160	260	350	350	350	350
	2.6	3.2	4.7	7.9	9.1	15.1	18.1	30.2	40	40	40	40
VHI590C-□E VHI590CT-□E	23	29	43	72	83	138	165	270	350	350	350	350
	2.7	3.3	4.9	8.2	9.4	15.6	18.7	31.2	40	40	40	40
VHI590S-□ VHI590ST-□	23	27	40	68	77	130	155	260	350	350	350	350
	2.6	3.1	4.6	7.7	8.8	14.7	17.6	29.4	40	40	40	40

#### ◆ Single-Phase 230 VAC 50 Hz

Unit = Upper values: lb-in/Lower values: N·m

Model	Speed r/min Gear Ratio	300	250	166	100	83	50	41	25	16	12.5	8.3
		<b>5</b>	<b>6</b>	<b>9</b>	<b>15</b>	<b>18</b>	<b>30</b>	<b>36</b>	<b>60</b>	<b>90</b>	<b>120</b>	<b>180</b>
VHI590C-□E VHI590CT-□E	29	34	52	87	100	166	200	330	350	350	350	350
	3.3	3.9	5.9	9.9	11.3	18.8	22.6	37.7	40	40	40	40

● Gearheads and decimal gearheads are sold separately. Decimal gearheads are not available for V Series.

● Enter the gear ratio in the box (□) within the model name. A colored background indicates gear shaft rotation in the same direction as the motor shaft; a white background indicates rotation in the opposite direction.

● The speed is calculated by dividing the motor's synchronous speed (50 Hz: 1500 r/min, 60 Hz: 1800 r/min) by the gear ratio. The actual speed is 2~20% less than the displayed value, depending on the size of the load.

## ■ Gearmotor — Torque Table when Right-Angle Gearhead is Attached

Right-Angle Gearheads are available for the World K Series only.

→Page A-196

## ■ Permissible Overhung Load and Permissible Thrust Load

Motor (Round shaft type)→Page A-11

Gearhead→Page A-11

## ■ Permissible Load Inertia J for Gearhead

→Page A-12

**Dimensions** Scale 1/4, Unit = inch (mm)

Mounting screws are included with gearheads. Dimensions for screws → A-223

● **World K Series**

◆ **Lead Wire Type**

<b>Motor</b>	<b>Gearhead</b>
51K90GU-AWU	5GU□KA
51K90GU-CWE	
51K90GU-SW	
Weight: 7.0 lb. (3.2 kg)	Weight: 3.3 lb. (1.5 kg)

**DXF** A035U (5GU3KA~180KA)

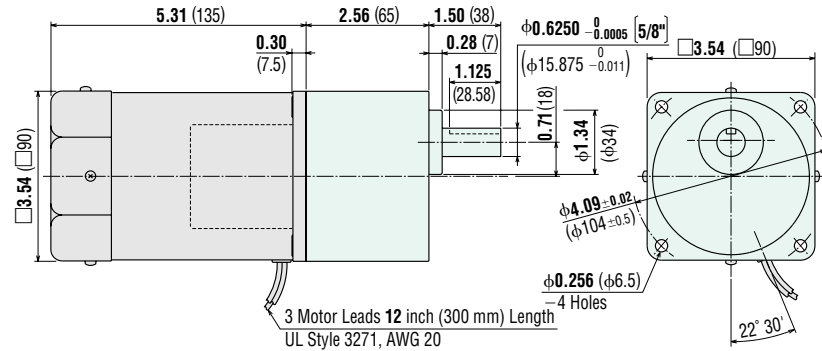

● **Key and Key Slot (Scale 1/2)**

(The key is provided with the gearhead)

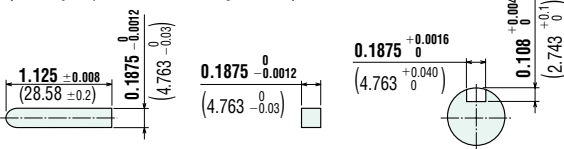

◆ **Terminal Box Type**

<b>Motor</b>	<b>Gearhead</b>
51K90GU-AWTU	5GU□KA
51K90GU-CWTE	
51K90GU-SWT	
Weight: 7.3 lb. (3.3 kg)	Weight: 3.3 lb. (1.5 kg)

**DXF** A036U (5GU3KA~180KA)

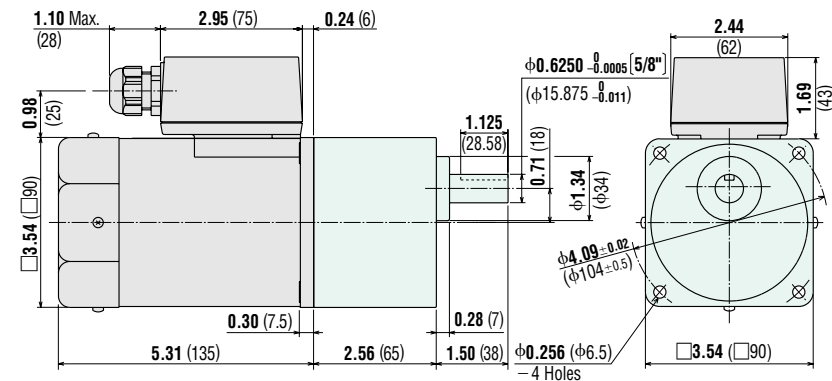

- Use cable (VCTF) with a diameter of  $\phi 0.24$  inch ( $\phi 6$  mm)~ $\phi 0.47$  inch ( $\phi 12$  mm).
- Details of Terminal Box → Page A-224

● **Key and Key Slot (Scale 1/2)**

(The key is provided with the gearhead)

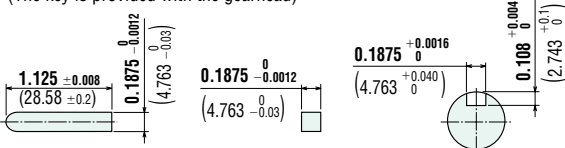

**Round Shaft Type**

51K90A-AWU  
51K90A-CWE  
51K90A-SW  
Weight: 7.0 lb. (3.2 kg)

**DXF** A333

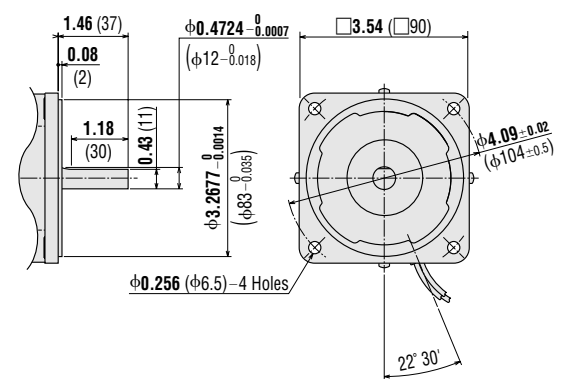

**Round Shaft Type**

51K90A-AWTU  
51K90A-CWTE  
51K90A-SWT  
Weight: 7.3 lb. (3.3 kg)

**DXF** A334

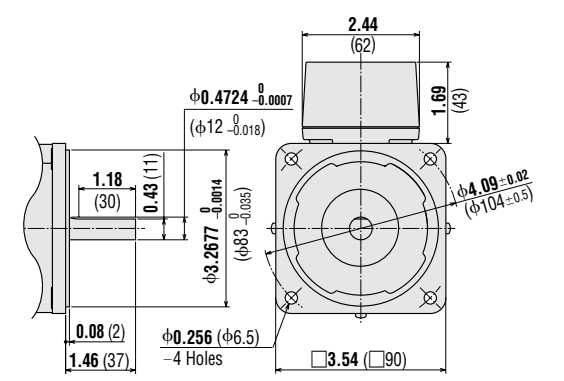

◆ Conduit Box Type

**Motor**  
51K90GU-FCH  
51K90GU-ECH

Weight: 8.1 lb. (3.7 kg)

**Gearhead**

5GU□KA

Weight: 3.3 lb. (1.5 kg)

DXF A806 (5GU3KA~180KA)

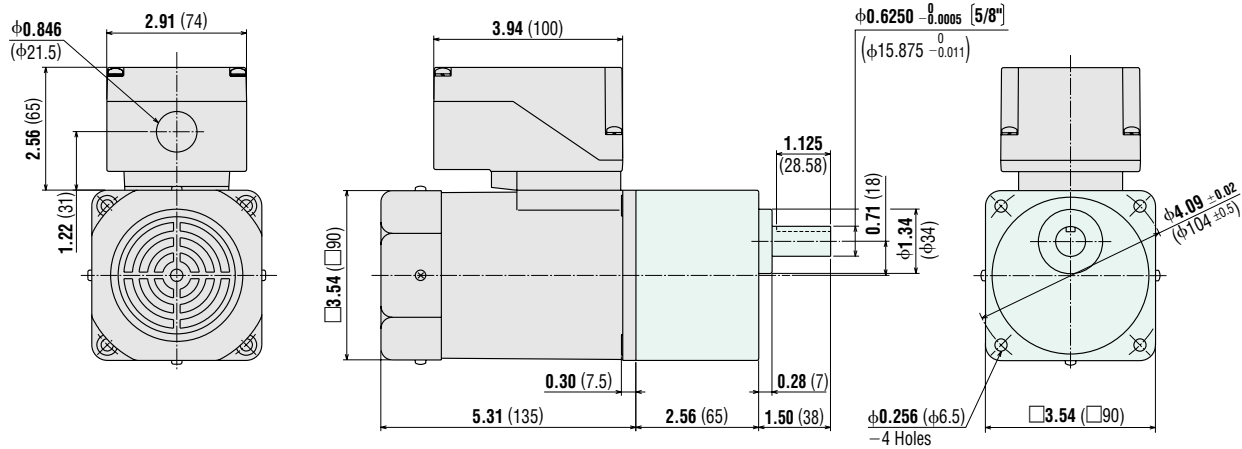

3 Motor Leads: UL Style 3266, AWG 20  
1 Ground Lead: UL Style 3266, AWG 18

●Details of Terminal Box → Page A-224

●Key and Key Slot (Scale 1/2)

(The key is provided with the gearhead)

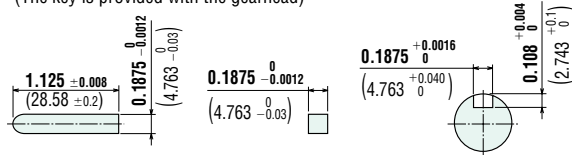

**Motor**  
51K90GU-SH

Weight: 7.3 lb. (3.3 kg)

**Gearhead**

5GU□KA

Weight: 3.3 lb. (1.5 kg)

DXF A807 (5GU3KA~180KA)

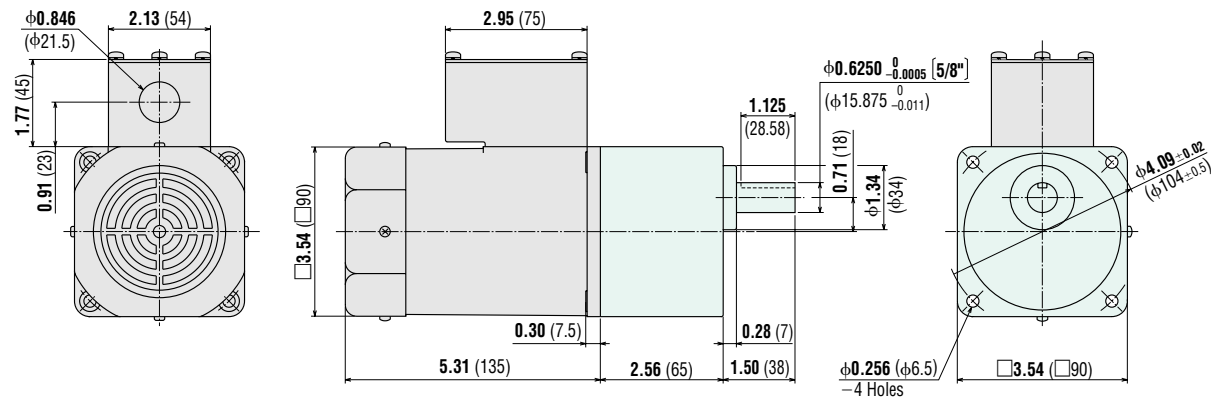

3 Motor Leads: UL Style 3266, AWG 20  
1 Ground Lead: UL Style 3266, AWG 18

●Details of Terminal Box → Page A-224

●Key and Key Slot (Scale 1/2)

(The key is provided with the gearhead)

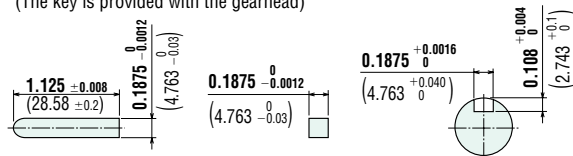

### Round Shaft Type

**5IK90A-FCH**  
**5IK90A-ECH**

Weight: 8.1 lb. (3.7 kg)

**DXF** A815

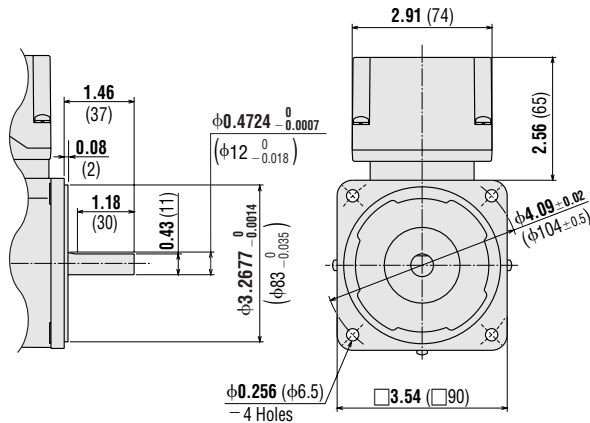

●Details of Terminal Box → Page A-224

### Round Shaft Type

**5IK90A-SH**

Weight: 7.3 lb. (3.3 kg)

**DXF** A816

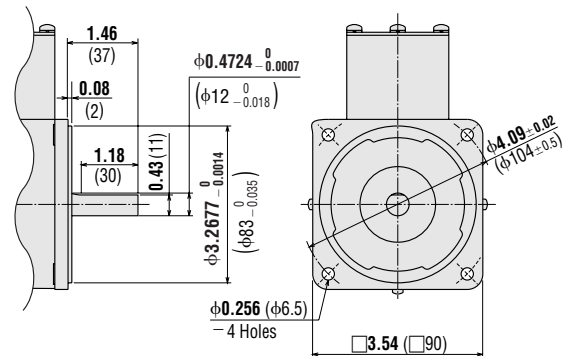

### Decimal Gearheads (for World K Series)

**5GU10XKB** (for **5GU□KA**)  
**5GU10XK** (for **5GU□KHA**)

Weight: 1.3 lb. (0.6 kg)

**DXF** A029

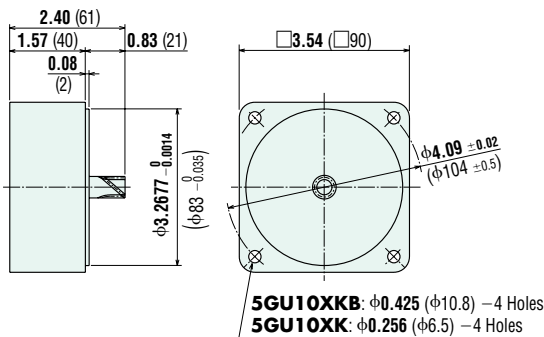

### High-Power Type Gearhead (for World K Series)

**5GU□KHA** Weight: 4.2 lb. (1.9 kg)

**DXF** A038U

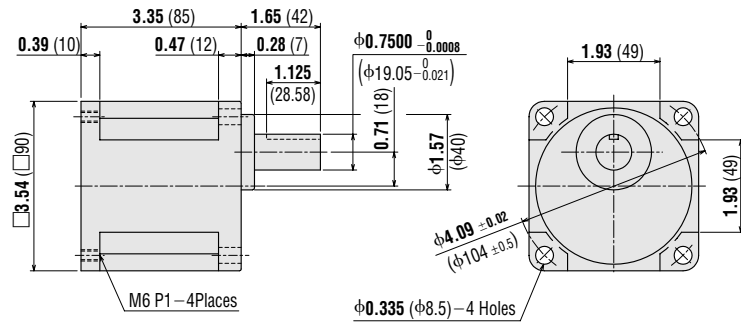

### Key and Key Slot (Scale 1/2)

(The key is provided with the gearhead)

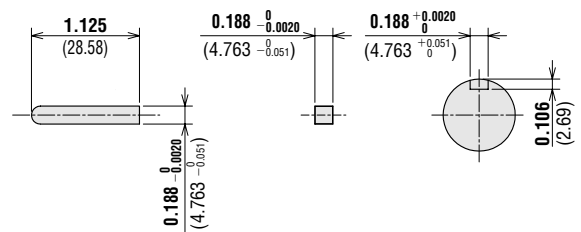

- Introduction
- Induction Motors
- Reversible Motors
- Synchronous Motors
- Torque Motors
- Waterright Motors
- Magnetic Brake
- Clutch & Brake
- Brake Pack
- Right-Angle Gearheads
- Accessories
- Before Using a Standard AC Motor

● V Series

◆ Lead Wire Type

VH1590A-□U, VH1590C-□E, VH1590S-□ (Combination Type)

Weight: 10 lb. (4.7 kg) including gearhead

Motor Model: VH1590A-GVR, VH1590C-GVR, VH1590S-GVR

Gearhead Model: GVR5G□

- DXF A397A (GVR5G5~15)  
 A397B (GVR5G18~36)  
 A397C (GVR5G60~180)

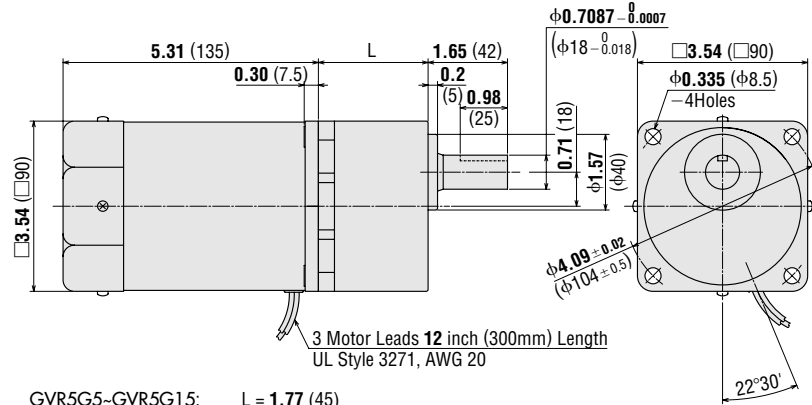

- GVR5G5-GVR5G15: L = 1.77 (45)  
 GVR5G18-GVR5G36: L = 2.28 (58)  
 GVR5G60-GVR5G180: L = 2.76 (70)

● Key and Key Slot (Scale 1/2)

(The key is provided with the gearhead)

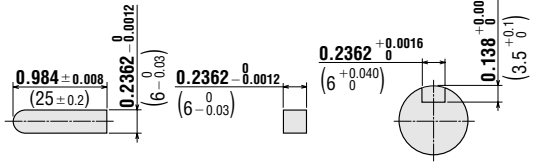

◆ Terminal Box Type

VH1590AT-□U, VH1590CT-□E, VH1590ST-□ (Combination Type)

Weight: 11 lb. (4.8 kg) including gearhead

Motor Model: VH1590AT-GVR, VH1590CT-GVR, VH1590ST-GVR

Gearhead Model: GVR5G□

- DXF A398A (GVR5G5~15)  
 A398B (GVR5G18~36)  
 A398C (GVR5G60~180)

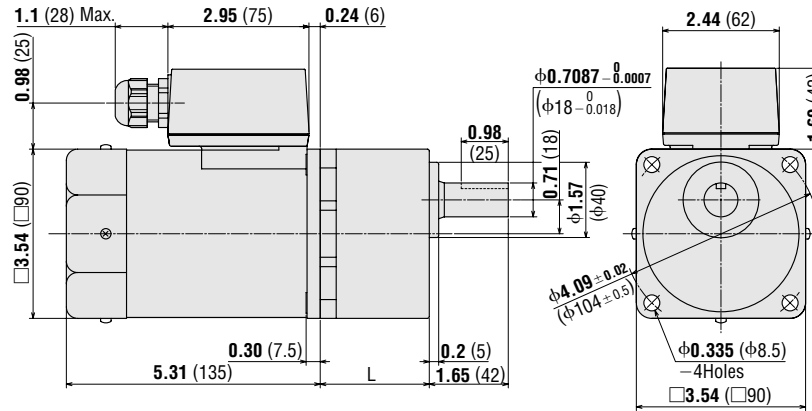

- GVR5G5-GVR5G15: L = 1.77 (45)  
 GVR5G18-GVR5G36: L = 2.28 (58)  
 GVR5G60-GVR5G180: L = 2.76 (70)

● Key and Key Slot (Scale 1/2)

(The key is provided with the gearhead)

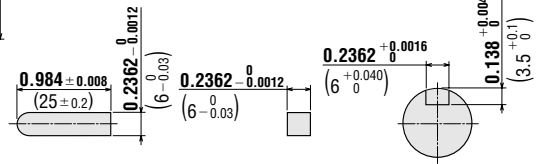

- Use cable (VCTF) with a diameter of  $\phi 0.24$  inch ( $\phi 6$  mm)~ $\phi 0.47$  inch ( $\phi 12$  mm).
- Details of Terminal Box → Page A-224



● **Capacitor** (included with single-phase motors)

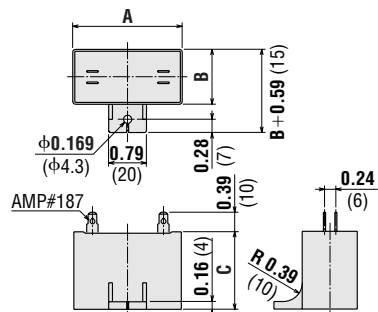

Motor Model	Capacitor Model	Dimensions in. (mm)			Weight oz. (g)
		A	B	C	
<b>5IK90GU-AW(T)U</b> <b>5IK90A-AW(T)U</b>	CH200CFAUL	2.28 (58)	1.14 (29)	1.61 (41)	3.4 (95)
<b>5IK90GU-CW(T)E</b> <b>5IK90A-CW(T)E</b> <b>VHI590C-□E</b> <b>VHI590CT-□E</b>	CH60BFAUL	2.28 (58)	1.14 (29)	1.61 (41)	3.0 (85)
<b>VHI590A-(T)U</b> <b>VHI590AT-□U</b>	CH250CFAUL	2.28 (58)	1.38 (35)	1.97 (50)	4.9 (140)

● If you need to order a capacitor without a motor, add "-C" to the capacitor model name shown. A capacitor cap is included with a capacitor.

■ **Connection Diagrams**

Lead Wire Type	
<p><b>5IK90GU-AWU</b> <b>5IK90GU-CWE</b> <b>VHI590A-□U</b> <b>VHI590C-□E</b></p> <p>CCW → CW</p> <p>Line CW SW CCW</p> <p>Black Red White</p> <p>Motor</p> <p>Capacitor</p> <p>To rotate the motor in a clockwise (CW) direction, flip switch SW to CW.</p> <p>To rotate it in a counterclockwise (CCW) direction, flip switch SW to CCW.</p>	<p><b>5IK90GU-SW</b> <b>VHI590S-□</b></p> <p>Line R (U) S (V) T (W)</p> <p>Red White Black</p> <p>Motor</p> <p>CCW</p> <p>To change the rotation direction, change any two connections between U, V and W.</p>

Terminal Box Type	
<p><b>5IK90GU-AWTU</b> <b>5IK90GU-CWTE</b> <b>VHI590AT-□U</b> <b>VHI590CT-□E</b></p> <p>CCW → CW</p> <p>Line SW Line CW</p> <p>Capacitor</p> <p>Protective Earth (P.E.)</p> <p>To rotate the motor in a clockwise (CW) direction, flip switch SW to CW.</p> <p>To rotate it in a counterclockwise (CCW) direction, flip switch SW to CCW.</p>	<p><b>5IK90GU-SWT</b> <b>VHI590ST-□</b></p> <p>Line R (U) S (V) T (W)</p> <p>Motor</p> <p>Protective Earth (P.E.)</p> <p>To change the rotation direction, change any two connections between U, V and W.</p>

Conduit Box Type	
<p><b>5IK90GU-FCH</b> <b>5IK90GU-ECH</b></p> <p>CCW → CW</p> <p>Line SW CCW White Red Black Green/Yellow</p> <p>Motor</p> <p>Protective Earth (P.E.)</p> <p>To rotate the motor in a clockwise (CW) direction, flip switch SW to CW.</p> <p>To rotate it in a counterclockwise (CCW) direction, flip switch SW to CCW.</p>	<p><b>5IK90GU-SH</b></p> <p>Line R (U) S (V) T (W)</p> <p>Red White Black Green/Yellow</p> <p>Motor</p> <p>Protective Earth (P.E.)</p> <p>To change the rotation direction, change any two connections between U, V and W.</p>

● **Inner Connection Diagram for 4-Terminal Capacitor**

Terminals of the capacitor are connected as shown in the figure. For lead wire connection, use one lead wire per terminal.

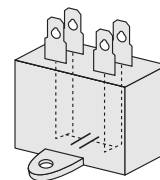

- The direction of motor rotation is as viewed from the shaft end of the motor.
- CW represents the clockwise direction, while CCW represents the counterclockwise direction.
- Connection diagrams are also valid for the equivalent round shaft type.
- **How to connect a capacitor** → Page A-225

**Note:**

- Change the direction of single-phase motor rotation only after bringing the motor to a stop. If an attempt is made to change the direction of rotation while the motor is rotating, the motor may ignore the reversing command or change its direction of rotation after some delay.

■ **List of Motor and Gearhead Combinations for V Series**

Model numbers for motor and gearhead combinations are shown below.

Model	Motor Model	Gearhead Model
<b>VHI590A-□U</b>	VHI590A-GVR	GVR5G□
<b>VHI590C-□E</b>	VHI590C-GVR	
<b>VHI590S-□</b>	VHI590S-GVR	
<b>VHI590AT-□U</b>	VHI590AT-GVR	
<b>VHI590CT-□E</b>	VHI590CT-GVR	
<b>VHI590ST-□</b>	VHI590ST-GVR	

- Enter the gear ratio in the box (□) within the model name.

Induction Motors **BH Series****200 W (1/4 HP)**Frame Size:  4.09 in. ( 104 mm sq.)(Cable Type,  
Right-Angle Hollow Shaft)(Terminal Box Type,  
Parallel Shaft)(Terminal Box Type,  
Right-Angle Solid Shaft)

## Features

- **BH** Series motors provide 200W output power and up to 530 lb-in (60 N·m) of torque in a compact 4.09 in. sq. (104 mm sq.) mounting configuration.
  - Right-angle gearheads are available.
  - For easy installation, the **BH** Series motor and gearhead come pre-assembled.
- \* Motors and gearheads are also available separately.

## Specifications — Continuous Rating



Model		Output Power	Voltage	Frequency	Current	Starting Torque	Rated Torque	Rated Speed	Capacitor			
Upper Model Name: Combination Type Lower Model Name( ): Round Shaft Type		HP	W	VAC	Hz	A	oz-in	N·m	oz-in	N·m	r/min	μF
Cable Type Dimension ①	Terminal Box Type Dimension ②											
<b>BHI62F-□RH</b> <b>BHI62F-□RA</b> <b>BHI62F-□</b> <b>(BHI62F-A)</b>	<b>BHI62FT-□RH</b> <b>BHI62FT-□RA</b> <b>BHI62FT-□</b> <b>(BHI62FT-A)</b>	1/4	200	Single-Phase 110	60	3	124	0.88	180	1.27	1500	40
							139	0.98				
<b>BHI62E-□RH</b> <b>BHI62E-□RA</b> <b>BHI62E-□</b> <b>(BHI62E-A)</b>	<b>BHI62ET-□RH</b> <b>BHI62ET-□RA</b> <b>BHI62ET-□</b> <b>(BHI62ET-A)</b>	1/4	200	Single-Phase 220	60	1.5	139	0.98	180	1.27	1500	10
				Single-Phase 230	50		210	1.52	1250			
				Single-Phase 230	60		180	1.27	1500			
<b>BHI62ST-□RH</b> <b>BHI62ST-□RA</b> <b>BHI62ST-□</b> <b>(BHI62ST-A)</b>	<b>BHI62ST-□RH</b> <b>BHI62ST-□RA</b> <b>BHI62ST-□</b> <b>(BHI62ST-A)</b>	1/4	200	Three-Phase 200	50	1.1	210	1.49	210	1.49	1250	—
				Three-Phase 200	60	1.1	177	1.25	177	1.25	1500	
				Three-Phase 220	60	0.95	174	1.23	174	1.23	1550	
				Three-Phase 230	60	0.95	167	1.18	167	1.18	1600	

(TP): Contains a built-in thermal protector. If a motor overheats for any reason, the thermal protector is opened and the motor stops. When the motor temperature drops, the thermal protector closes and the motor restarts. Be sure to turn the motor off before inspecting.

- **Details of Safety Standard** → Page G-2
- Enter the gear ratio in the box (□) within the model name.
- The values in the table are for the motor only.

## Product Line

- **Combination Type**
- ◆ **Right-Angle Shaft**

Type	Power Supply Voltage	Model	Gear Ratio
Hollow Shaft Cable Type	Single-Phase 110/115 VAC	<b>BHI62F-□RH</b>	<b>6~180</b>
	Single-Phase 220/230 VAC	<b>BHI62E-□RH</b>	<b>6~180</b>
Hollow Shaft Terminal Box Type	Single-Phase 110/115 VAC	<b>BHI62FT-□RH</b>	<b>6~180</b>
	Single-Phase 220/230 VAC	<b>BHI62ET-□RH</b>	<b>6~180</b>
	Three-Phase 200/220/230 VAC	<b>BHI62ST-□RH</b>	<b>6~180</b>
Solid Shaft Cable Type	Single-Phase 110/115 VAC	<b>BHI62F-□RA</b>	<b>6~180</b>
	Single-Phase 220/230 VAC	<b>BHI62E-□RA</b>	<b>6~180</b>
Solid Shaft Terminal Box Type	Single-Phase 110/115 VAC	<b>BHI62FT-□RA</b>	<b>6~180</b>
	Single-Phase 220/230 VAC	<b>BHI62ET-□RA</b>	<b>6~180</b>
	Three-Phase 200/220/230 VAC	<b>BHI62ST-□RA</b>	<b>6~180</b>

- Enter the gear ratio in the box (□) within the model name.

## ◆ Parallel Shaft

Type	Power Supply Voltage	Model	Gear Ratio
Cable Type	Single-Phase 110/115 VAC	<b>BHI62F-□</b>	<b>3.6~180</b>
	Single-Phase 220/230 VAC	<b>BHI62E-□</b>	<b>3.6~180</b>
Terminal Box Type	Single-Phase 110/115 VAC	<b>BHI62FT-□</b>	<b>3.6~180</b>
	Single-Phase 220/230 VAC	<b>BHI62ET-□</b>	<b>3.6~180</b>
	Three-Phase 200/220/230 VAC	<b>BHI62ST-□</b>	<b>3.6~180</b>

- Enter the gear ratio in the box (□) within the model name.

## ● Round Shaft Type

Type	Power Supply Voltage	Model
Cable Type	Single-Phase 110/115 VAC	<b>BHI62F-A</b>
	Single-Phase 220/230 VAC	<b>BHI62E-A</b>
Terminal Box Type	Single-Phase 110/115 VAC	<b>BHI62FT-A</b>
	Single-Phase 220/230 VAC	<b>BHI62ET-A</b>
	Three-Phase 200/220/230 VAC	<b>BHI62ST-A</b>

## ■ Gearmotor — Torque Table

### ● Right-Angle Shaft

#### ◆ Single-Phase 115/230 VAC 60 Hz, Three-Phase 230 VAC 60 Hz

Unit = Upper Values: lb-in/Lower Values: N·m

Model	Speed r/min	300	200	120	100	60	50	30	20	15	10
	Gear Ratio	<b>6</b>	<b>9</b>	<b>15</b>	<b>18</b>	<b>30</b>	<b>36</b>	<b>60</b>	<b>90</b>	<b>120</b>	<b>180</b>
<b>BHI62F-□RH, BHI62F-□RA, BHI62FT-□RH</b> <b>BHI62FT-□RA, BHI62E-□RH, BHI62E-□RA</b> <b>BHI62ET-□RH, BHI62ET-□RA</b>	49	73	123	147	240	290	380	450	530	530	
	5.6	8.3	13.9	16.7	27.8	33.4	43	51.5	60	60	
<b>BHI62ST-□RH, BHI62ST-□RA</b> (230 VAC)	46	69	114	137	220	270	380	450	530	530	
	5.2	7.8	12.9	15.5	25.8	31	43	51.5	60	60	

#### ◆ Single-Phase 230 VAC 50 Hz

Unit = Upper Values: lb-in/Lower Values: N·m

Model	Speed r/min	250	167	100	83	50	42	25	17	12.5	8.3
	Gear Ratio	<b>6</b>	<b>9</b>	<b>15</b>	<b>18</b>	<b>30</b>	<b>36</b>	<b>60</b>	<b>90</b>	<b>120</b>	<b>180</b>
<b>BHI62E-□RH, BHI62E-□RA</b> <b>BHI62ET-□RH, BHI62ET-□RA</b>	59	88	146	177	290	310	380	450	530	530	
	6.7	10	16.6	20	33.3	36	43	51.5	60	60	

### ● Parallel Shaft

#### ◆ Single-Phase 115/230 VAC 60 Hz, Three-Phase 230 VAC 60 Hz

Unit = Upper Values: lb-in/Lower Values: N·m

Model	Speed r/min	500	300	200	120	100	60	50	30	20	15	10
	Gear Ratio	<b>3.6</b>	<b>6</b>	<b>9</b>	<b>15</b>	<b>18</b>	<b>30</b>	<b>36</b>	<b>60</b>	<b>90</b>	<b>120</b>	<b>180</b>
<b>BHI62F-□, BHI62FT-□</b> <b>BHI62E-□, BHI62ET-□</b>	36	61	91	145	174	290	340	350	350	350	350	
	4.1	6.9	10.3	16.4	19.7	32.8	39.3	40	40	40	40	
<b>BHI62ST-□</b> (230 VAC)	33	56	84	134	161	260	320	350	350	350	350	
	3.8	6.4	9.6	15.2	18.3	30.4	36.5	40	40	40	40	

#### ◆ Single-Phase 230 VAC 50 Hz

Unit = Upper Values: lb-in/Lower Values: N·m

Model	Speed r/min	417	250	167	100	83	50	42	25	17	12.5	8.3
	Gear Ratio	<b>3.6</b>	<b>6</b>	<b>9</b>	<b>15</b>	<b>18</b>	<b>30</b>	<b>36</b>	<b>60</b>	<b>90</b>	<b>120</b>	<b>180</b>
<b>BHI62E-□, BHI62ET-□</b>	43	72	108	173	200	340	350	350	350	350	350	
	4.9	8.2	12.3	19.6	23.5	39.2	40	40	40	40	40	

- Enter the gear ration in the box (□) within the model name. A colored background indicates gear shaft ration in the same direction as the motor shaft; a white background indicates rotation in the opposite direction.
- Decimal gearheads are not available for the **BH** Series.
- The speed is calculated by dividing the motor's synchronous speed (50 Hz: 1500 r/min, 60 Hz: 1800 r/min) by the gear ratio. The actual speed is 2~20% less than the displayed value, depending on the size of the load.

## ■ Permissible Overhung Load and Permissible Thrust Load

Motor (Round shaft type) →Page A-11

Gearhead →Page A-11

## ■ Permissible Load Inertia J for Gearhead

→Page A-12

## Mounting Method for Hollow Shaft Gearheads

### Stepped-Down Shaft

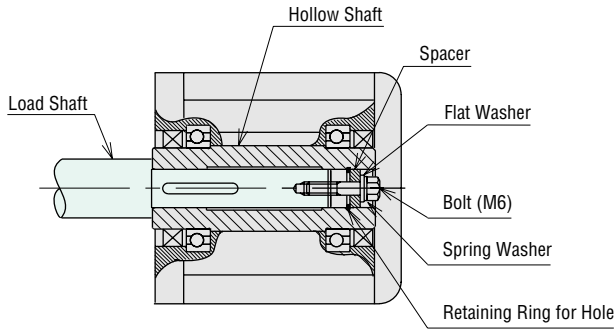

### Straight Load Shaft

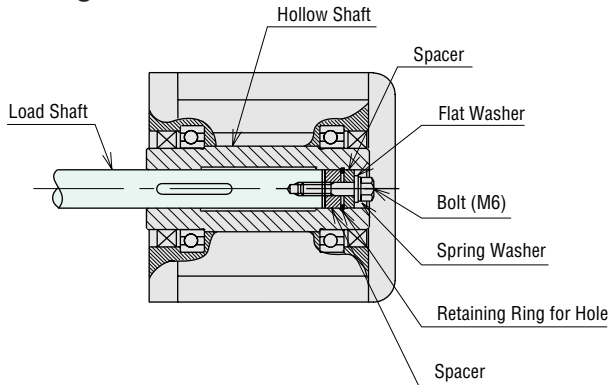

These diagrams show how to mount loads depending on the shape of the shaft.

The tolerance of the inner diameter for the hollow shaft is finished as H8, and "key slot" processing is given to mount the load shaft. The recommended tolerance of the load shaft is h7. Apply a coating of molybdenum disulfide or similar grease to the inner diameter of the load shaft to prevent binding. Recommended load shaft dimensions are shown below.

### Recommended size of inner diameter for the hollow shaft and load shaft

Unit = inch (mm)

Model	BH6G2-□RH
Inner diameter of hollow shaft H8	$\phi 0.9843^{+0.0013}_0$ ( $\phi 25^{+0.033}_0$ )
Recommended load shaft diameter h7	$\phi 0.9843^{0}_{-0.0008}$ ( $\phi 25^{0}_{-0.021}$ )

- Replace the safety cover after installing the load shaft.

#### Note:

- Be careful not to apply a shock to the hollow shaft when mounting a load. It may damage the bearing inside the gearhead.



◆ Combination Type Right-Angle, Solid Shaft Cable Type

**BHI62F-□RA, BHI62E-□RA**

Weight: 22 lb. (10.0 kg) including gearhead

Motor Model: BHI62F-G2, BHI62E-G2

Gearhead Model: BH6G2-□RA

DXF A300

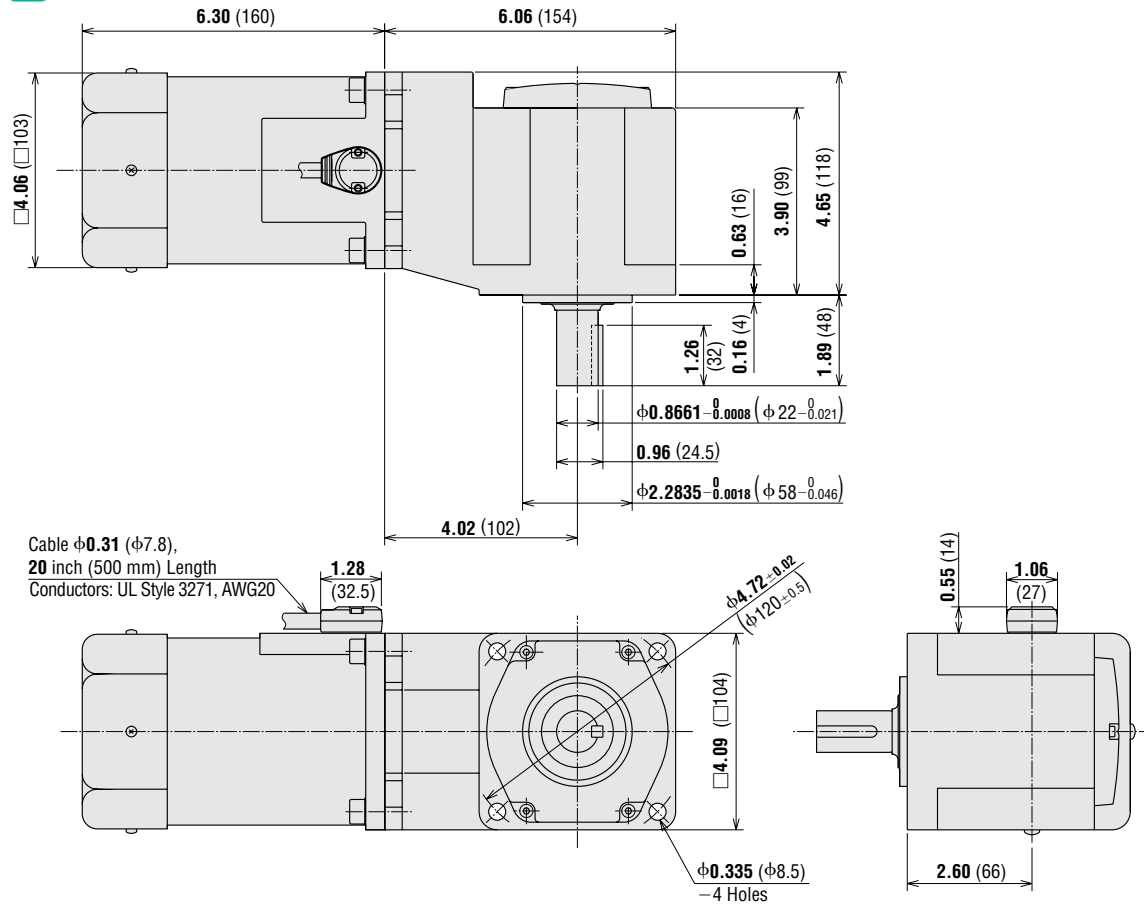

● Key and Key Slot (Included) (Scale 1/2)

At the time of shipment, the parallel key is pressed into the key slot.

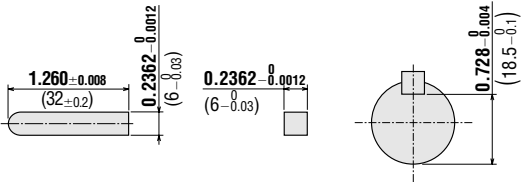

◆ Combination Type Right-Angle, Hollow Shaft with Terminal Box

BHI62FT-□RH, BHI62ET-□RH, BHI62ST-□RH

Weight: 22 lb. (10.0 kg) including gearhead

Motor Model: BHI62FT-G2, BHI62ET-G2, BHI62ST-G2

Gearhead Model: BH6G2-□RH

DXF A301

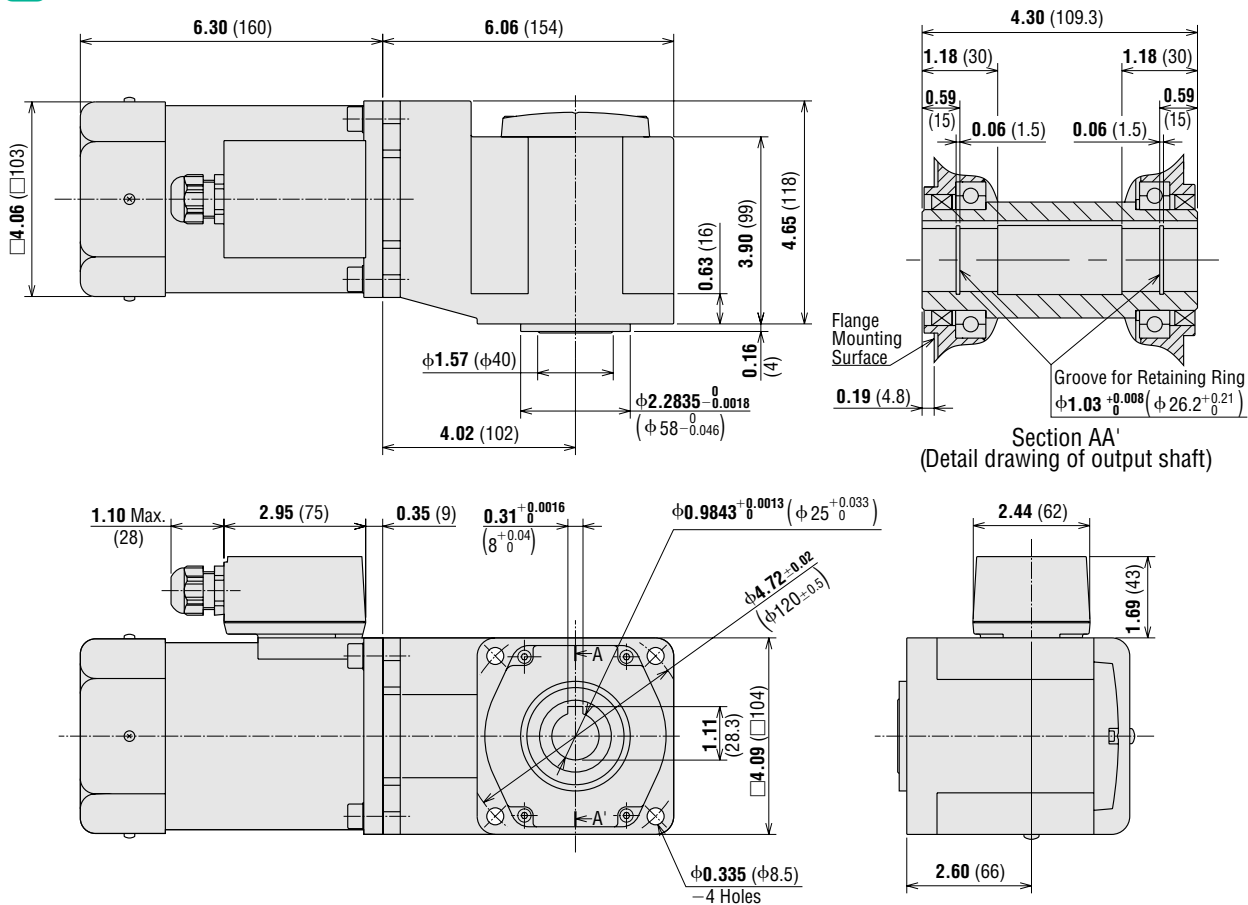

- Use cable (VCTF) with a diameter of  $\phi 0.24$  inch ( $\phi 6$  mm) ~  $\phi 0.47$  inch ( $\phi 12$  mm).
- Details of Terminal Box → Page A-224

● Key (Included) (Scale 1/2)

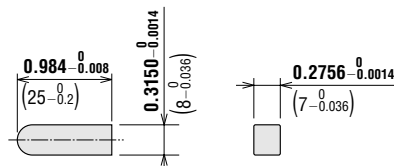

Introduction

Induction Motors

Reversible Motors

Synchronous Motors

Torque Motors

Waterlight Motors

Magnetic Brake

Clutch & Brake

Brake Pack

Right-Angle Gearheads

Accessories

Before Using a Standard AC Motor

◆ Combination Type Right-Angle, Solid Shaft with Terminal Box

BHI62FT-□RA, BHI62ET-□RA, BHI62ST-□RA

Weight: 22 lb. (10.0 kg) including gearhead

Motor Model: BHI62FT-G2, BHI62ET-G2, BHI62ST-G2

Gearhead Model: BH6G2-□RA

DXF A302

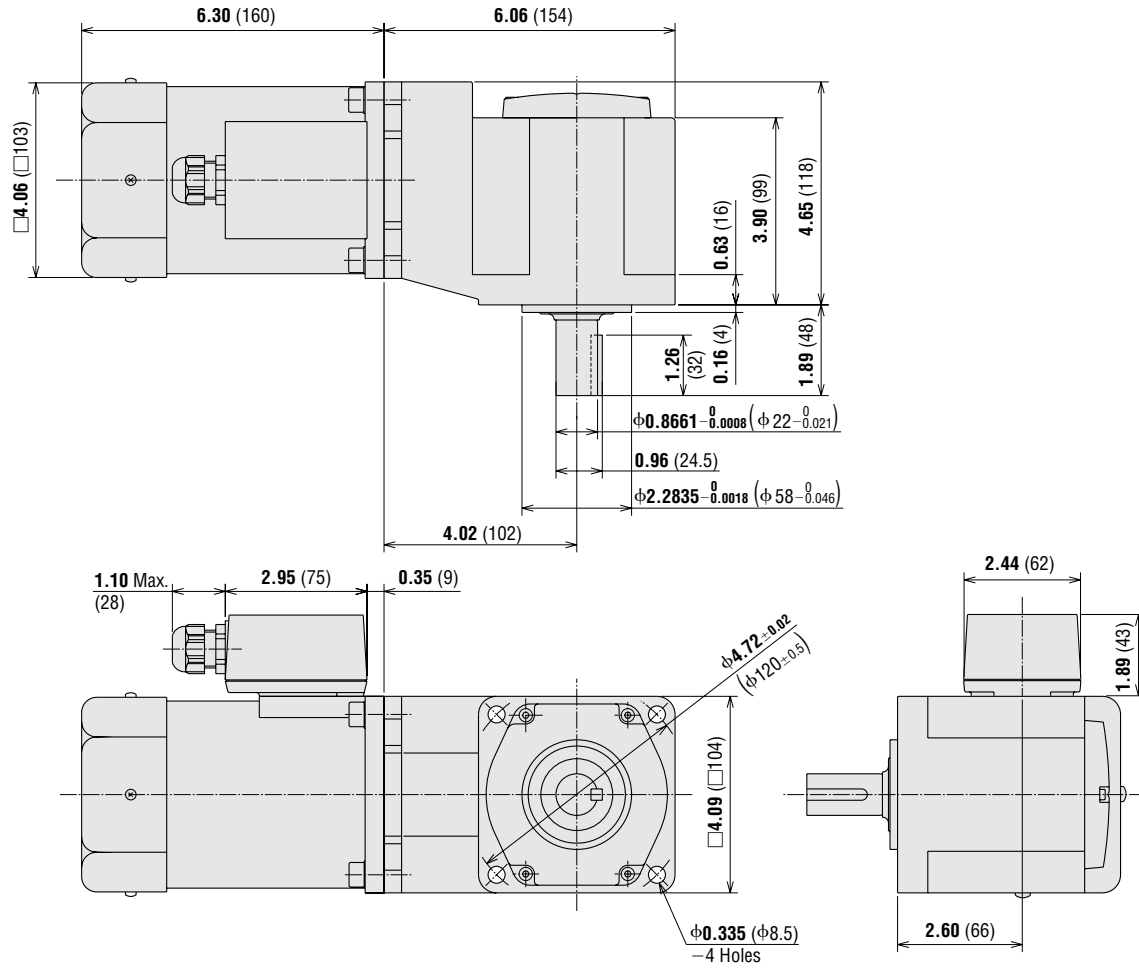

- Use cable (VCTF) with a diameter of  $\phi 0.24$  inch ( $\phi 6$  mm)~ $\phi 0.47$  inch ( $\phi 12$  mm).
- Details of Terminal Box → Page A-224

● Key and Key Slot (Included) (Scale 1/2)

At the time of shipment, the parallel key is pressed into the key slot.





◆ Combination Type, Parallel Shaft Type Cable Type

BHI62F-□, BHI62E-□

Weight: 18 lb. (8.0 kg) including gearhead

Motor Model: BHI62F-G2, BHI62E-G2

Gearhead Model: BH6G2-□

DXF A303

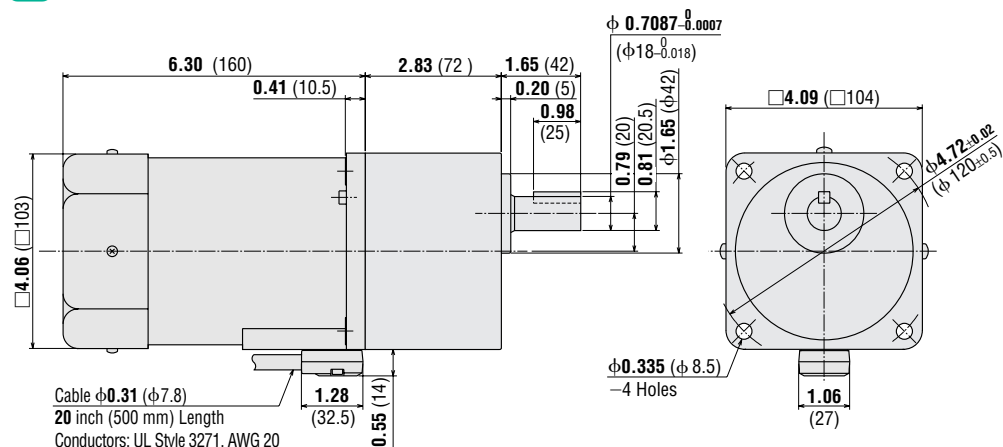

●Key and Key Slot (Included) (Scale 1/2)

At the time of shipment, the parallel key is pressed into the key slot.

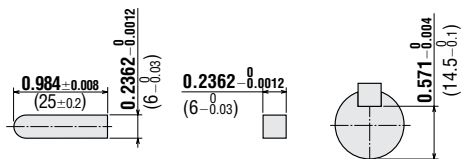

◆ Combination Type, Parallel Shaft Type with Terminal Box

BHI62FT-□, BHI62ET-□, BHI62ST-□

Weight: 18 lb. (8.0 kg) including gearhead

Motor Model: BHI62FT-G2, BHI62ET-G2, BHI62ST-G2

Gearhead Model: BH6G2-□

DXF A304

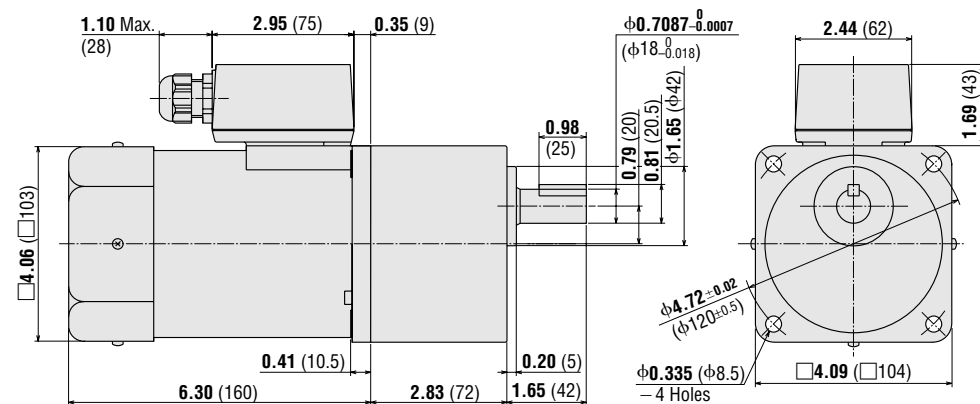

- Use cable (VCTF) with a diameter of  $\phi$  0.24 inch ( $\phi$ 6 mm)~ $\phi$ 0.47 inch ( $\phi$ 12 mm).
- Details of Terminal Box → Page A-224

●Key and Key Slot (Included) (Scale 1/2)

At the time of shipment, the parallel key is pressed into the key slot.

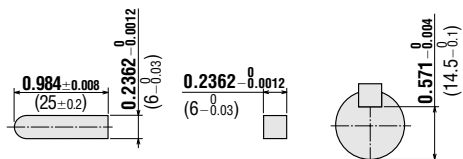

Introduction

Induction Motors

Reversible Motors

Synchronous Motors

Torque Motors

Waterlight Motors

Magnetic Brake

Clutch & Brake

Brake Pack

Right-Angle Gearheads

Accessories

Before Using a Standard AC Motor

◆ Round Shaft Type Cable Type

**BHI62F-A, BHI62E-A**

Weight: 11 lb. (5 kg)

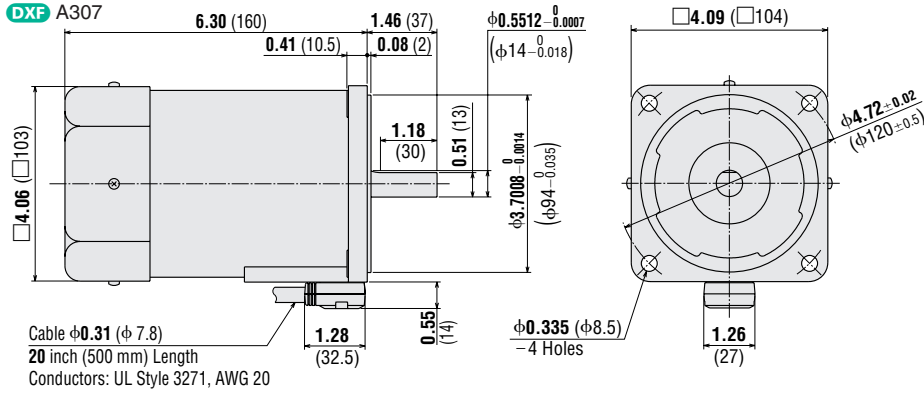

◆ Round Shaft Type with Terminal Box

**BHI62FT-A, BHI62ET-A, BHI62ST-A**

Weight: 11 lb. (5 kg)

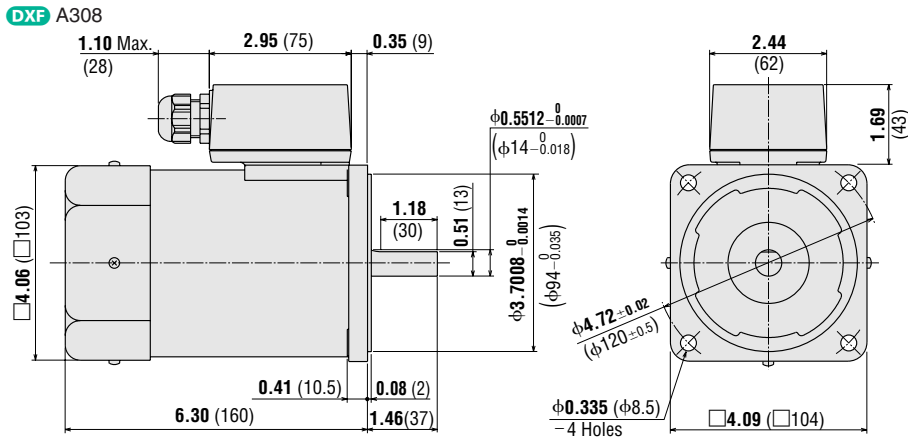

- Use cable (VCTF) with a diameter of  $\phi 0.24$  inch ( $\phi 6$  mm)~ $\phi 0.47$  inch ( $\phi 12$  mm).
- Details of Terminal Box → Page A-224

● Capacitor (Included with single-phase motors)

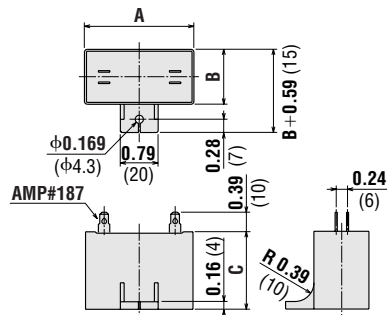

◆ Capacitor Dimensions Unit = inch (mm)

Model		Capacitor Model	A	B	C	Weight oz. (g)
Cable Type	Terminal Box Type					
<b>BHI62F-□RH</b>	<b>BHI62FT-□RH</b>	CH400CFAUL2	2.28 (58)	1.61 (41)	2.28 (58)	6.18 (175)
<b>BHI62F-□RA</b>	<b>BHI62FT-□RA</b>					
<b>BHI62F-□</b>	<b>BHI62FT-□</b>					
<b>BHI62F-A</b>	<b>BHI62FT-A</b>					
<b>BHI62E-□RH</b>	<b>BHI62ET-□RH</b>	CH100BFAUL	2.28 (58)	1.38 (35)	1.97 (50)	4.66 (132)
<b>BHI62E-□RA</b>	<b>BHI62ET-□RA</b>					
<b>BHI62E-□</b>	<b>BHI62ET-□</b>					
<b>BHI62E-A</b>	<b>BHI62ET-A</b>					

- If you need to order a capacitor without a motor, add "-C" to the capacitor model name shown. A capacitor cap is included with a capacitor.
- Enter the gear ratio in the box (□) within the model name.

## Connection Diagrams

Motor Type	Single-Phase Induction Motor *1		Three-Phase Induction Motor	
	Cable Type	Terminal Box Type *2	Terminal Box Type *2	
	Clockwise: To rotate the motor in a clockwise(CW) direction, flip SW to CW. Counterclockwise: To rotate the motor in a counterclockwise(CCW) direction, flip SW to CCW.		To rotate the motor in a counterclockwise direction, change any two connections between U, V and W.	
Parallel Shaft Combination Type	<b>BHI62□-3.6~9</b> <b>BHI62□-60~180</b>	<b>BHI62□T-3.6~9</b> <b>BHI62□T-60~180</b>	<b>BHI62ST-3.6~9</b> <b>BHI62ST-60~180</b>	
	<b>BHI62□-15~36</b>	<b>BHI62□T-15~36</b>	<b>BHI62ST-15~36</b>	
	Right-Angle Shaft Combination Type	<b>BHI62□-6RH~180RH</b> <b>BHI62□-6RA~180RA</b>	<b>BHI62□T-6RH~180RH</b> <b>BHI62□T-6RA~180RA</b>	<b>BHI62ST-6RH~180RH</b> <b>BHI62ST-6RA~180RA</b>
Round Shaft Type		<b>BHI62□-A</b>	<b>BHI62□T-A</b>	<b>BHI62ST-A</b>

- \*1 Enter **F** or **E** (power supply voltage) in the box (□) within the model name.
- \*2 Connecting to the terminal block for terminal box type  
Applicable lead wire: AWG 24~12 (0.2 mm<sup>2</sup> ~4.0 mm<sup>2</sup>)  
Strip length: 0.31 inch (8 mm)

**Note:**

- Change the direction of single-phase motor rotation only after bringing the motor to a stop. If an attempt is made to change the direction of rotation while the motor is rotating, the motor may ignore the reversing command or change its direction of rotation after some delay.
- **How to Connect a Capacitor**  
→ Page A-225

- The direction of motor rotation is as viewed from the shaft end of the motor.
- CW represents the clockwise direction, while CCW represents counterclockwise direction.

### Inner Connection Diagram for 4-Terminal Capacitor

Terminals of the capacitor are connected as shown in the figure. For lead wire connection, use one lead wire per terminal.

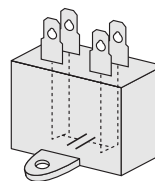

## List of Motor and Gearhead Combinations

### Combination Type Right-Angle Shaft

Model	Motor Model	Gearhead Model
<b>BHI62F-□RH</b>	BHI62F-G2	BH6G2-□RH
<b>BHI62F-□RA</b>		BH6G2-□RA
<b>BHI62FT-□RH</b>	BHI62FT-G2	BH6G2-□RH
<b>BHI62FT-□RA</b>		BH6G2-□RA
<b>BHI62E-□RH</b>	BHI62E-G2	BH6G2-□RH
<b>BHI62E-□RA</b>		BH6G2-□RA
<b>BHI62ET-□RH</b>	BHI62ET-G2	BH6G2-□RH
<b>BHI62ET-□RA</b>		BH6G2-□RA
<b>BHI62ST-□RH</b>	BHI62ST-G2	BH6G2-□RH
<b>BHI62ST-□RA</b>		BH6G2-□RA

Enter the gear ratio in the box (□) within the model name.

### Combination Type Parallel Shaft

Model	Motor Model	Gearhead Model
<b>BHI62F-□</b>	BHI62F-G2	BH6G2-□
<b>BHI62FT-□</b>	BHI62FT-G2	
<b>BHI62E-□</b>	BHI62E-G2	
<b>BHI62ET-□</b>	BHI62ET-G2	
<b>BHI62ST-□</b>	BHI62ST-G2	

Enter the gear ratio in the box (□) within the model name.

1/750 HP  
1 W1/125 HP  
6 W1/50 HP  
15 W1/30 HP  
25 W1/19 HP  
40 W1/12 HP  
60 W1/8 HP  
90 W1/4 HP  
200 W1/19-1/8 HP  
40-90 W  
(2-Pole)

## 2-Pole, High Speed Type Induction Motors

# 40 W (1/19 HP) • 60 W (1/12 HP) • 90 W (1/8 HP)

Frame Size: □ 3.15 in. (□ 80 mm), □ 3.54 in. (□ 90 mm)

### Specifications — Continuous Rating

Model	Output Power		Voltage	Frequency	Current	Starting Torque		Rated Torque		Rated Speed	Capacitor
	HP	W	VAC	Hz	A	oz-in	mN·m	oz-in	mN·m	r/min	μF
<b>41K40A-BA</b>	1/19	40	Single-Phase 115	60	0.8	13.4	95	18.4	130	3000	8.0
<b>51K60A-BA</b>	1/12	60	Single-Phase 115	60	1.2	17	120	26	185	3200	12.0
<b>51K90A-BFUL</b>	1/8	90	Single-Phase 115	60	2.0	31	220	39	280	3200	20.0

Contains a built-in thermal protector. If a motor overheats for any reason, the thermal protector is opened and the motor stops. When the motor temperature drops, the thermal protector closes and the motor restarts. Be sure to turn the motor off before inspecting.

• Details of Safety Standard → Page G-2

### Dimensions Scale 1/4, Unit = inch (mm)

#### 41K40A-BA

Weight: 3.3 lb. (1.5 kg)

A327U

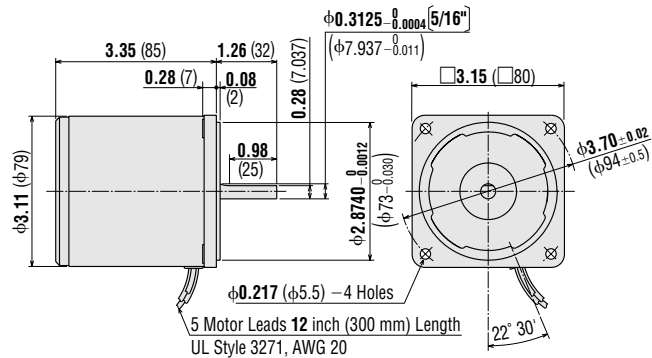

#### 51K60A-BA

Weight: 5.5 lb. (2.5 kg)

A329U

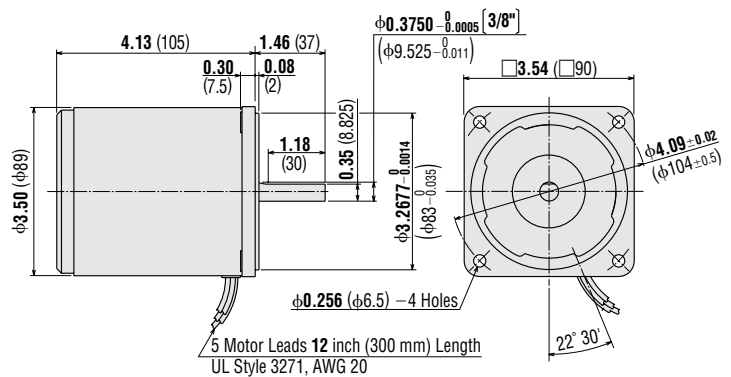

#### 51K90A-BFUL

Weight: 5.9 lb. (2.7 kg)

A331

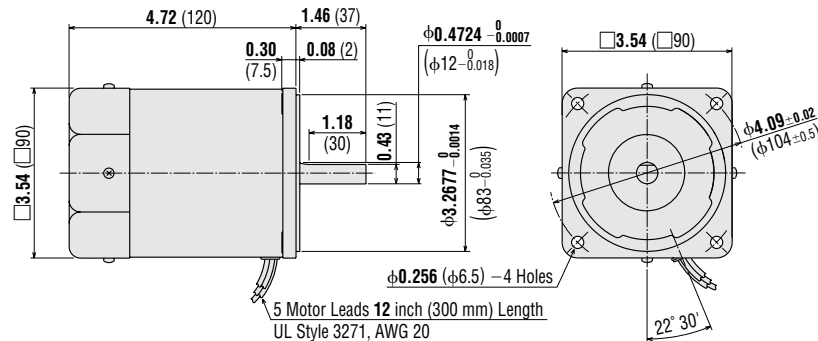

● **Capacitor** (included with the motors)

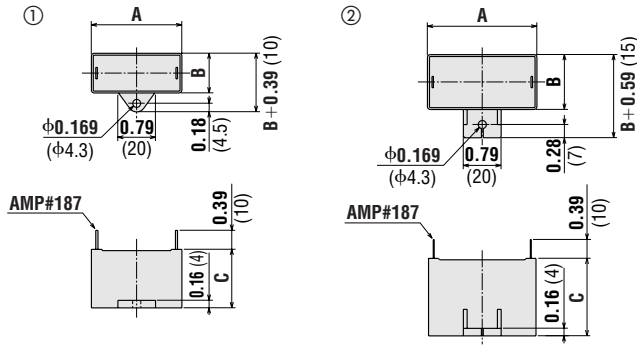

Motor Model	Capacitor Model	Dimensions in. (mm)			Weight oz. (g)	Dimensions Number
		A	B	C		
<b>4IK40A-BA</b>	CH80UL	1.50 (38)	0.83 (21)	1.22 (31)	1.2 (35)	①
<b>5IK60A-BA</b>	CH120UL	1.89 (48)	0.83 (21)	1.22 (31)	1.6 (44)	①
<b>5IK90A-BFUL</b>	CH200UL	2.28 (58)	0.91 (23)	1.46 (37)	2.3 (65)	②

● If you need to order a capacitor without a motor, add "-C" to the capacitor model number shown. A capacitor cap is included with a capacitor.

■ **Connection Diagrams**

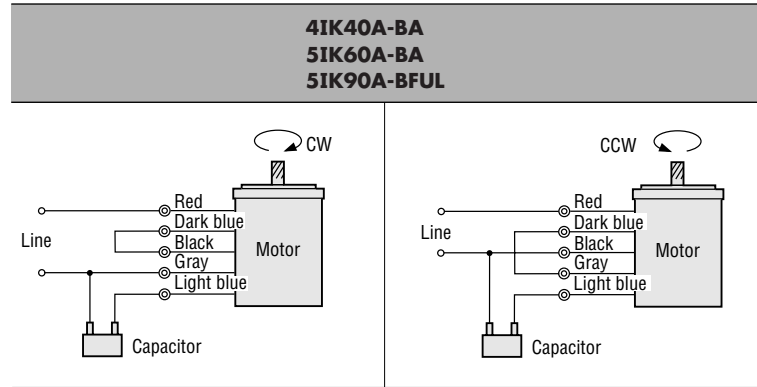

- The direction of motor rotation is as viewed from the shaft end of the motor.
- CW represents the clockwise direction, while CCW represents the counterclockwise direction.

**Note:**

- Change the direction of a single-phase motor rotation only after bringing the motor to a stop. If an attempt is made to change the direction of rotation while the motor is rotating, the motor may ignore the reversing command or change its direction of rotation after some delay.