

ONE-TIME

OT/OTN/OTS



CLASS K-5



FOR VERSATILITY AND ECONOMY, THESE GENERAL PURPOSE FUSES ARE HARD TO BEAT

OT, OTN and OTS general purpose fuses provide low cost protection for feeder and branch circuits serving lighting, heating, and other non-motor loads. OT, OTN and OTS fuses will safely interrupt available short circuit currents up to 50,000 amperes in all ratings.

OT, OTN and OTS fuses are *not* rejection fuses – care should be taken to ensure that replacement fuses do not have lower interrupting ratings than original fuses.

OTN 15 through 60 satisfy the Canadian electrical code requirement for Type “P,” low melting-point, non-time delay fuses.

Features/Benefits

- **Easy to read imprint label** for quick recognition and replacement
- **Low cost** for high protection value

HIGHLIGHTS:

- Versatile
- Lowest cost protection for circuits serving non-inductive loads

APPLICATIONS:

- Feeders
- Branch Circuits
- Resistive Heating
- Residential and Small Commercial Installations

Ratings

- **OT**
AC: 1 to 600A
250VAC, 50kA I.R.
- **OTN (Canada)**
AC: 15 to 60A
250VAC, 50kA I.R.
- **OTS**
AC: 1 to 600A
600VAC, 50kA I.R.

Approvals

- UL Listed to Standard 248-9
 - CSA Certified to Standard C22.2 No. 248.9*
- * The Canadian Electrical Code requires these fuses in ratings 15 through 60A to be of the low melting point design use OTN 15-60.



GENERAL PURPOSE / CLASS K-5 FUSES OT/OTN/OTS

Standard Fuse Ampere Ratings, Catalog Numbers

Ampere Rating	Catalog Number		Ampere Rating	Catalog Number		Ampere Rating	Catalog Number	
	250V	600V		250V	600V		250V	600V
1	OT1	OTS1	30	OT30, OTN30*	OTS30	125	OT125	OTS125
2	OT2	OTS2	35	OT35, OTN35*	OTS35	150	OT150	OTS150
3	OT3	OTS3	40	OT40, OTN40*	OTS40	175	OT175	OTS175
4	OT4	OTS4	45	OT45, OTN45*	OTS45	200	OT200	OTS200
5	OT5	OTS5	50	OT50, OTN 50*	OTS50	225	OT225	OTS225
6	OT6	OTS6	60	OT60, OTN60*	OTS60	250	OT250	OTS250
7	OT7	OTS7	65	OT65	OTS65	300	OT300	OTS300
8	OT8	OTS8	70	OT70	OTS70	350	OT350	OTS350
10	OT10	OTS10	75	OT75	OTS75	400	OT400	OTS400
12	OT12	OTS12	80	OT80	OTS80	450	OT450	OTS450
15	OT15, OTN15*	OTS15	90	OT90	OTS90	500	OT500	OTS500
20	OT20, OTN20*	OTS20	100	OT100	OTS100	600	OT600	OTS600
25	OT25, OTN 25*	OTS25	110	OT110	OTS110			

* In Canada

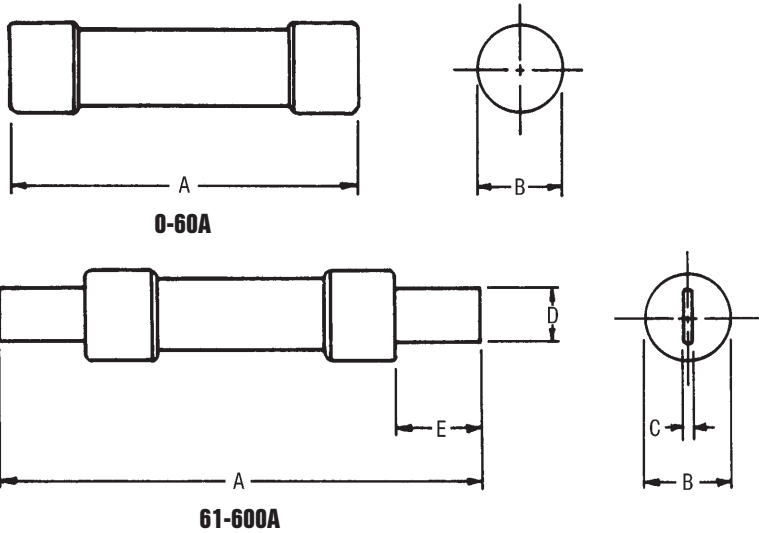

Recommended Fuse Blocks With Box Connectors For One-Time Class K-5 Fuses

Fuse Ampere Rating	Catalog Number			
	250V		600V	
	1 Pole	3 pole	1 pole	3 pole
0-30	20306	20308	60306	60308
31-60	20606	20608	60606	60608
61-100	21036	21038	61036	61038
101-200	22001	22003	62001	62003
201-400	24001	24003	64001	64003
401-600	2631	2633	6631	6633

A variety of pole configurations and termination provisions is available. Refer to the fuse block section of this catalog for details.

Dimensions

AMPERE RATING	A		B		C		D		E	
	In.	mm	In.	mm	In.	mm	In.	mm	In.	mm
250V-OT, OTN FUSES										
0-30	2	51	9/16	14	-	-	-	-	-	-
31-60	3	76	13/16	21	-	-	-	-	-	-
61-100	5-7/8	149	1-1/16	27	1/8	3	3/4	19	1	25
101-200	7-1/8	181	1-9/16	40	3/16	5	1-1/8	28	1-3/8	35
201-400	8-5/8	219	2-1/16	53	1/4	6	1-5/8	41	1-7/8	48
401-600	10-3/8	264	2-9/16	66	1/4	6	2	51	2-1/4	57
600V-OTS FUSES										
0-30	5	127	13/16	21	-	-	-	-	-	-
31-60	5-1/2	139	1-1/16	27	-	-	-	-	-	-
61-100	7-7/8	200	1-5/16	34	1/8	3	3/4	19	1	25
101-200	9-5/8	244	1-13/16	46	3/16	5	1-1/8	28	1-3/8	35
201-400	11-5/8	295	2-9/16	66	1/4	6	1-5/8	41	1-7/8	48
401-600	13-3/8	340	3-1/8	80	1/4	6	2	51	2-1/4	57

GENERAL PURPOSE / CLASS K-5 FUSES

OT/OTN/OTS

OT30 to 600; OTN 30, 60

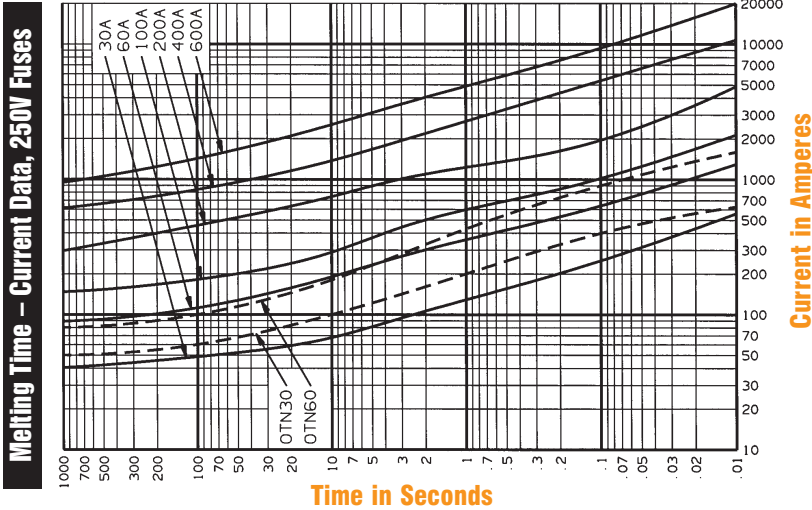

OTS30 to 600

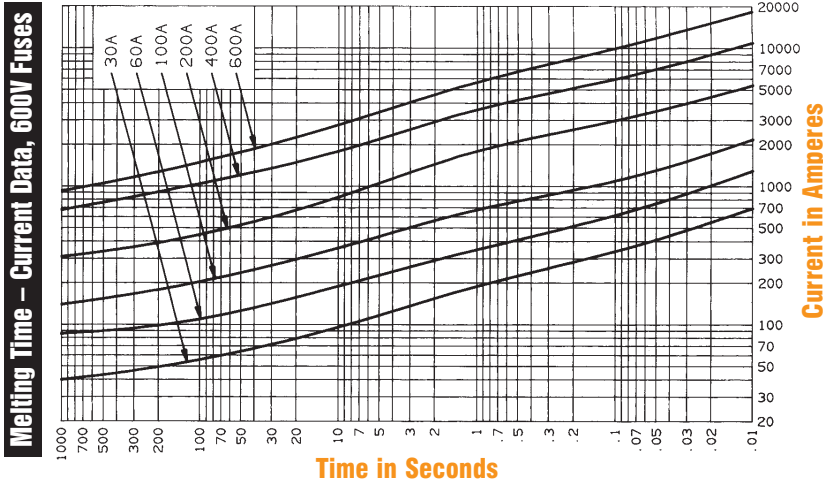

Peak Let-Thru Current Data – OT, OTN & OTS30 to 600, 250 and 600 Volts AC

