

Catalog 140
X Switches
80 A-630A

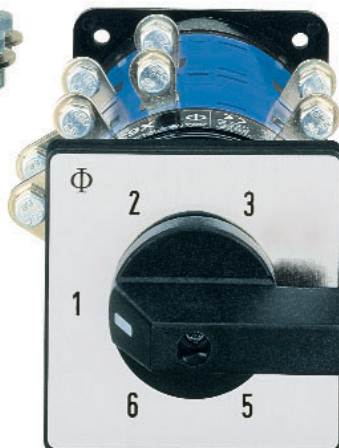

KRAUS & NAIMER

The development of the Blue Line rotary switch, contactor and motor starter product ranges is based on more than seventy-five years experience by Kraus & Naimer in the design and manufacture of electrical switchgear. Kraus & Naimer pioneered the introduction of the cam operated rotary switch and continues to be recognized as the world leader in that product field.

BLUE LINE

Blue Line products are protected by numerous patents throughout the industrial world. They are built to national and international standards and designed to withstand adverse temperatures and climates.

Blue Line products are accepted and universally recognized for their quality and workmanship. They are supported by a worldwide sales and service organization.

The Kraus & Naimer Registered Trademark

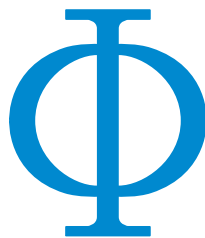

WORLDWIDE SYMBOL
FOR QUALITY SWITCHGEAR

Disconnectors and Main Switches acc. to IEC 60947-3 see Catalog 500

Contents	Page
Construction Data	2
Dimensions and Nominal Ratings	2
How to order	3, 4
Switch Function and Configuration	
ON/OFF Switches	5
Double-throw Switches	6
Multi-step Switches	7-10
Types of Mounting	
Front Mounting	11
Base Mounting	11
Handles	12
Escutcheon Plates	13
Technical Data	14
International Standards and Approvals	15
Dimensions	
Handles and Escutcheon Plates	16
Front Mounting and Base Mounting:	
X63, X100, X200	17
X160, X400	18
X630	19
Blue Line Switchgear:	
Summary	20

Construction Data

X switches are highly compact cam operated switches which meet the requirements of IEC 60947-3 for switches. Each stage contains 6 double-break contacts operated by a triple cam, providing a minimum length dimension for mounting purposes with a larger number of contacts. They are mainly used as general application switches and multi-step switches.

X switches are available with up to 6 stages. Up to 36 contacts are operated in up to 18 switch positions.

Switching angle may be 20°, 30°, 45°, 60° or 90°.

A wide range of optional extras, escutcheon plates and handles is available.

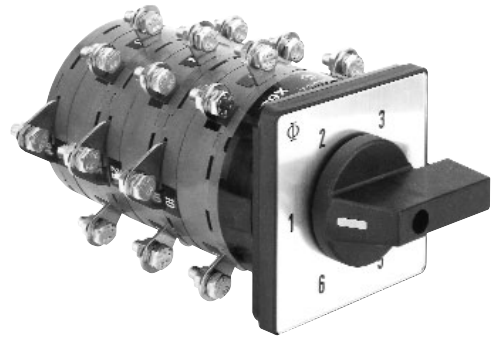

Switch Size

Type

Nominal Ratings

S2

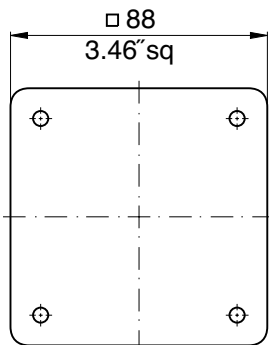

X63
X160

S3

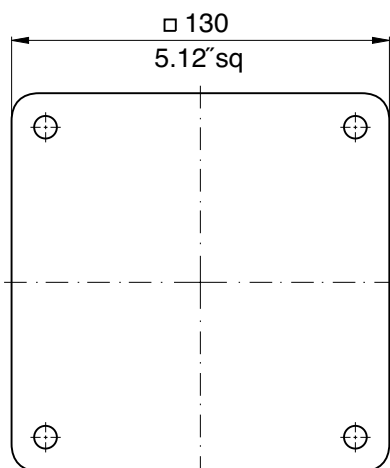

X100
X200
X400
X630

Acc. to IEC 60947-3, EN 60947-3, VDE 0660 part 107

Insulation
Voltage¹

U_i

V

690
690

Thermal
Current

I_u/I_{th}^2

A

80 (63)
180 (150)

Motor Rating AC-20B³

3 phase, 3 pole

380-440 V 500 V

A

80
125

A

80
125

690
690
690
690

125 (100)
240 (200)
450 (400)
630 (560)

125
240
300
300

125
240
250
250

How to order

Disconnectors and Main Switches according to IEC 60947-3 see Catalog 500

Three types of data (shown below) are required for ordering Blue Line cam-operated switches. Code numbers for ordering are shown in this catalog.

1. Type of Switch

The type of switch required may be easily selected by referring to the table on page 2 which shows the thermal current, power rating and dimensions of each switch. For further technical details, refer to page 14.

2. Switch Function

The code numbers for standard switches shown on pages 5-10 indicate the switch function, escutcheon plate, handle and any optional extras.

Additional coding to modify type and color of handle and escutcheon plate is explained below.

3. Type of Mounting

Types of mounting are shown on page 11.

Specify the mounting code to indicate required mounting.

X63

A202-600

VE

Modification of Switches

The part number for switch function and options may be modified in cases where items are required other than standard. The modification may involve the escutcheon plate inscription, color combination of escutcheon plate and handle, type of escutcheon plate and handle or the optional extra.

Switch Size	Escutcheon Plate Frame	Handle	Escutcheon Plate Backing	Escutcheon Plate Lettering	Dash Number
S2, S3	electro-gray	electro-gray	brushed alu	black	-100
S2, S3	electro-gray	electro-gray	black	mat silver	-500
S2, S3	black	black	brushed alu	black	-600
S2, S3	black	black	black	mat silver	-700

The standard switch consists of a transparent escutcheon plate with brushed aluminum backing and black inscription. The escutcheon plate frame is black as well as the handle. Above there are further color combinations of escutcheon plate and handle which are available. The appropriate dash number must be substituted in the switch function coding to specify other color combinations as required.

Example: The complete coding for switch type X63 with a 3 pole ON/OFF switch function, electro-gray handle and electro-gray escutcheon plate frame with brushed aluminum backing and black inscription which reads 0-1 is as follows: **X63 A202-100 E**.

How to order

Special programs for escutcheon plate and handle combinations

The following is a list of special programs for escutcheon plate and handle combinations. They may be obtained by specifying any one of the following two (2) digits dash-numbers as a part of the overall dash-number. It is still necessary to prefix these two digit numbers with the first digit which represents the color combination required.

- **000** = without escutcheon plate, without handle
- **.01** = without escutcheon plate
- **.02** = without handle
- **.03** = with square escutcheon plate without lettering
- **.04** = with rectangular escutcheon plate without lettering
- **.05** = with square escutcheon plate without lettering and without handle
- **.06** = with rectangular escutcheon plate without lettering and without handle
- **.07** = standard escutcheon plate, without lettering on rectangular section
- **.08** = with F-handle
- **.09** = with P-handle
- **.10** = escutcheon plate with frame and fixation ring only
- **.11** = without escutcheon plate, but with handle bearing plate

Example: The complete coding for switch type X63 with a 3 pole ON/OFF switch function with electro-gray escutcheon plate frame, square escutcheon plate without lettering, brushed aluminum plate backing and electro-gray handle reads as follows: **X63 A202-103 VE.**

Handles, Escutcheon Plates and Optional Extras

The handles for standard switches shown on pages 5-10 are suitable for mounting units with four hole mounting. Alternative types of handles available are illustrated on page 12.

When a handle, escutcheon plate or optional extra is required but not covered by the dash number, the code number for the selected component should be entered separately. A comprehensive range of available standard escutcheon plates is illustrated on page 13. Non-standard or special escutcheon plate engravings are available at extra cost.

The large number of optional extras and enclosures is covered in Catalog **101**.

Switch Size

Blue Line X switches are available in sizes S2 and S3. These size codes indicate the dimensions of the mounting, the escutcheon plate and the handle as well as the size of the optional devices. Page 2 lists these sizes and the various switch types they include.

Ordering of Special Switches and Escutcheon Plates

When ordering special switches and escutcheon plates it is advisable to use our order form, as illustrated. The customer's requirements are shown in blue as an example.

For technical reasons, it may not be possible to follow the sequence of contacts requested by the customer. The final contact development which is sent with every switch will show the customer's original terminal markings.

Order forms are available on request.

ESCUTCHEON PLATE

POSITIONS	1	2	3	4	5	6	7	8	9	10	11	12	13	14	15	16	17	18	19	20	21	22	23	24	25	26	27	28	29	30	31	32	33	34	35	36	37	38	39	40	41	42	43	44	45	46	47	48		
1		X																																																
2			X																																															
3				X																																														
4					X																																													
5						X																																												
6							X																																											
7								X																																										

HANDLES	: G251	MOUNTING	: E	FIRM	:
ESCUTCHEON PLATE	: X63	OPTIONAL EXTRAS	:	DATE	:
SWITCH TYPE	:	SIGNED	:		

Switch Function and Configuration

X Switches

Function	Escutch. Plate	Type/Handle			Code	Stages			Connection Diagram
		X63-X200	X160, X400	X630		X63-X200	X160, X400	X630	

ON/OFF Switches with 60° Switching

1 pole					A200-600	1	1	1	<p>X63, X100, X200</p> 1 pole 2 pole 3 pole 4 pole 5 and 6 pole <p>X160, X400</p> 1 pole 2 pole 3 pole 4 pole 5 and 6 pole <p>X630</p> 1-6 pole
2 pole					A201-600	1	1	1	
3 pole					A202-600	1	1	2	
4 pole					A203-600	1	2	2	
5 pole					A341-600	1	2	3	
6 pole					A342-600	1	2	3	
1 pole					A200-620	1	1	1	<p>X63, X100, X200</p> 1 pole 2 pole 3 pole 4 pole 5 and 6 pole <p>X160, X400</p> 1 pole 2 pole 3 pole 4 pole 5 and 6 pole <p>X630</p> 1-6 pole
2 pole					A201-620	1	1	1	
3 pole					A202-620	1	1	2	
4 pole					A203-620	1	2	2	
5 pole					A341-620	1	2	3	
6 pole					A342-620	1	2	3	

ON/OFF Switches with 90° Switching

1 pole contacts					A290-600	1	1	1	<p>X63, X100, X200</p> 1 pole 2 pole 3 pole 4 pole <p>X160, X400</p> 1 pole 2 pole 3 pole 4 pole <p>X630</p> 1-4 pole
2 pole preclose 30°					A291-600	1	1	1	
3 pole					A292-600	1	1	2	
4 pole					A293-600	1	2	2	
1 pole contacts					A290-620	1	1	1	<p>X63, X100, X200</p> 1 pole 2 pole 3 pole 4 pole <p>X160, X400</p> 1 pole 2 pole 3 pole 4 pole <p>X630</p> 1-4 pole
2 pole preclose 30°					A291-620	1	1	1	
3 pole					A292-620	1	1	2	
4 pole					A293-620	1	2	2	

Function	Escutch. Plate	Type/Handle			Code	Stages			Connection Diagram
		X63-X200	X160, X400	X630		X63-X200	X160, X400	X630	

Double-throw Switches without “OFF” 60° Switching



























Function	Escutch. Plate	Type/Handle			Code	Stages			Connection Diagram
		X63-X200	X160, X400	X630		X63-X200	X160, X400	X630	
1 pole					A220-600	1	1	1	<p>X63, X100, X200</p> <p>X160, X400</p> <p>X630</p>
2 pole					A221-600	1	2	2	
3 pole					A222-600	1	2	3	
4 pole					A223-600	2	3	4	
5 pole					A369-600	2	4	4	
6 pole					A370-600	2	4	4	

Double-throw Switches with Center “OFF” 60° Switching

1 pole					A210-600	1	1	1	<p>X63, X100, X200</p> <p>X160, X400</p> <p>X630</p>
2 pole					A211-600	1	2	2	
3 pole					A212-600	1	2	3	
4 pole					A213-600	2	3	4	
1 pole					A210-620	1	1	1	<p>X630</p>
2 pole					A211-620	1	2	2	
3 pole					A212-620	1	2	3	
4 pole					A213-620	2	3	4	

Function	Escutch. Plate	Type/Handle			Code	Stages			Connection Diagram
		X63-X200	X160, X400	X630		X63-X200	X160, X400	X630	

















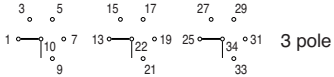

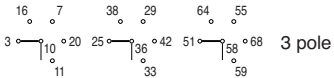

Multi-step Switches without "OFF"

1 pole 3 Step 2 pole 3 pole		  	  	  	A230-600 A250-600 A270-600	1 1 2	1 2 3	2 4 6	<p>X63, X100, X200</p>  1 pole  2 pole  3 pole
1 pole 4 Step 2 pole 3 pole		  	  	  	A231-600 A251-600 A271-600	1 2 3	2 4 6	2 4 6	<p>X63, X100, X200</p>  1 pole  2 pole  3 pole

*Type X400 with  handle

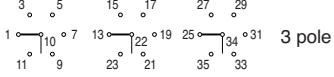
Function	Escutch. Plate	Type/Handle			Code	Stages			Connection Diagram
		X63- X200	X160, X400	X630		X63- X200	X160, X400	X630	

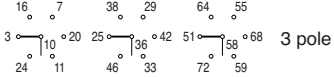



















Multi-step Switches without “OFF”

1 pole 5 Step 2 pole 3 pole					A232-600 A252-600 A272-600	1 2 3	2 4 6	3 6	<p>X63, X100, X200</p>  1 pole  2 pole  3 pole <p>X160, X400</p>  1 pole  2 pole  3 pole <p>X630</p>  1 pole  2 pole
1 pole 6 Step 2 pole 3 pole					A233-600 A253-600 A273-600	1 2 3	2 4 6	3 6	<p>X63, X100, X200</p>  1 pole  2 pole  3 pole <p>X160, X400</p>  1 pole  2 pole  3 pole <p>X630</p>  1 pole  2 pole













*Type X400 with  handle

Function	Escutch. Plate	Type/Handle			Code	Stages			Connection Diagram		
		X63-X200	X160, X400	X630		X63-X200	X160, X400	X630			

Multi-step Switches without “OFF”























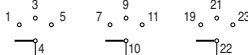

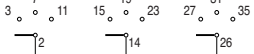







1 pole 7 Step					A234-600	2	4	4	<p>X63 X100 X200</p> 	<p>X160 X400</p> 	<p>X630</p> 
1 pole 8 Step					A235-600	2	4	4	<p>X63 X100 X200</p> 	<p>X160 X400</p> 	<p>X630</p> 
1 pole 9 Step					A236-600	2	4	5	<p>X63 X100 X200</p> 	<p>X160 X400</p> 	<p>X630</p> 

Multi-step Switches with “OFF”

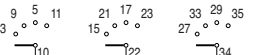

1 pole 2 Step 2 pole 3 pole					A240-600 A260-600 A280-600	1 1 1	1 2 3	1 2 3	<p>X63, X100, X200</p> <p>1 pole  2 pole </p> <p>3 pole </p> <p>X160, X400</p> <p>1 pole  2 pole </p> <p>3 pole </p> <p>X630</p> <p>1 pole  2 pole </p> <p>3 pole </p>
-----------------------------------	---	---	---	---	----------------------------------	-------------	-------------	-------------	---

Function	Escutch. Plate	Type/Handle			Code	Stages			Connection Diagram
		X63-X200	X160, X400	X630		X63-X200	X160, X400	X630	

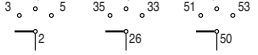
Multi-step Switches with “OFF”

1 pole 3 Step 2 pole 3 pole		  	  	  	A241-600 A261-600 A281-600	1 1 2	1 2 3	2 4 6	X63, X100, X200  1 pole  2 pole  3 pole
									X160, X400  1 pole  2 pole  3 pole
1 pole 4 Step 2 pole 3 pole		  	  	  	A242-600 A262-600 A282-600	1 2 3	2 4 6	2 4 6	X63, X100, X200  1 pole  2 pole  3 pole
									X160, X400  1 pole  2 pole  3 pole
									X630  1 pole  2 pole  3 pole

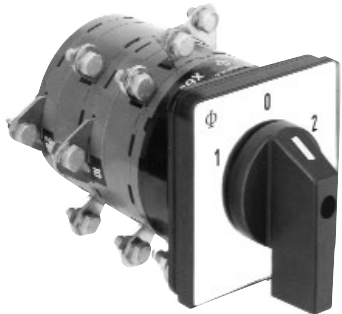
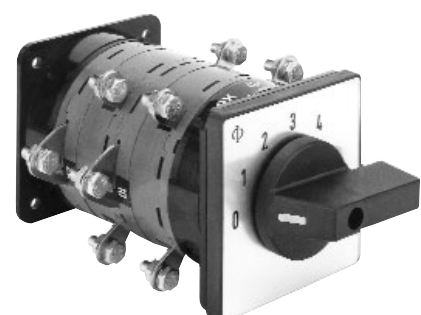



<p>Four Hole Panel Mounting and Base Mounting</p>	<p>Code</p>	<p>X63, X160</p>	<p>X100, X200- X630</p>
--	--------------------	----------------------	---------------------------------

	<p>Panel Mounting</p> <p>Four hole panel mounting</p> <p>Four hole panel mounting, protection IP 65</p>	<p>E</p> <p>EF</p>	<p>●</p> <p>●</p>	<p>●</p> <p>●</p>
	<p>Panel and base mounting</p> <p>Four hole panel mounting</p> <p>Four hole panel mounting, protection IP 65</p>	<p>ER</p> <p>ERF</p>	<p>●</p> <p>●</p>	<p>●</p> <p>●</p>
	<p>Base Mounting</p> <p>Four hole panel mounting</p>	<p>VE</p>	<p>●</p>	<p>●</p>

Handles

Type	Color	Code	Size S2 S3	
------	-------	------	------------------	--

Type	Color	Code	Size S2 S3	
------	-------	------	------------------	--

<p>R-Handle</p> 	<p>black red white electro-gray</p>	<p>G001 G002 G003 G007</p>	<p>● ● ● ● ● ● ● ●</p>
<p>F-Handle</p> 	<p>black red white electro-gray</p>	<p>G221 G222 G223 G227</p>	<p>● — ● — ● — ● —</p>
<p>Handwheel</p> 	<p>black</p>	<p>G971</p>	<p>— ●</p>
<p>Capstan Handle</p> 	<p>black</p>	<p>G931</p>	<p>— ●</p>

<p>I-Handle</p> 	<p>black red white electro-gray</p>	<p>G251 G252 G253 G257</p>	<p>● ● ● ● ● ● ● ●</p>
<p>K-Handle</p> 	<p>black red white electro-gray</p>	<p>G411 G412 G413 G417</p>	<p>● ● ● ● ● ● ● ●</p>
<p>P-Handle</p> 	<p>black red white electro-gray</p>	<p>G211 G212 G213 G217</p>	<p>● ● ● ● ● ● ● ●</p>

Escutcheon Plates

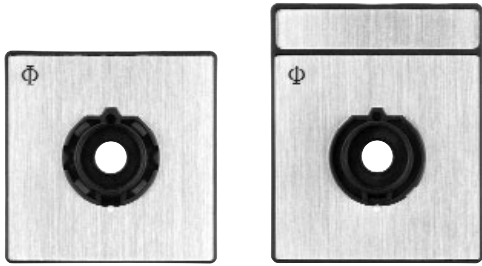

Square and rectangular escutcheon plates are available for each size of switch. The escutcheon plate consists of a frame and a faceplate having the switch positions which is then embossed with hot-foil backing. The escutcheon plate frame is an essential part of the switch and serves as a bearing surface for the handle. If the switch is to be mounted without an escutcheon plate we would recommend the handle bearing plate T100-04.

Standard Letterings Available

(over 500 standard letterings, special letterings on request)

30° switching

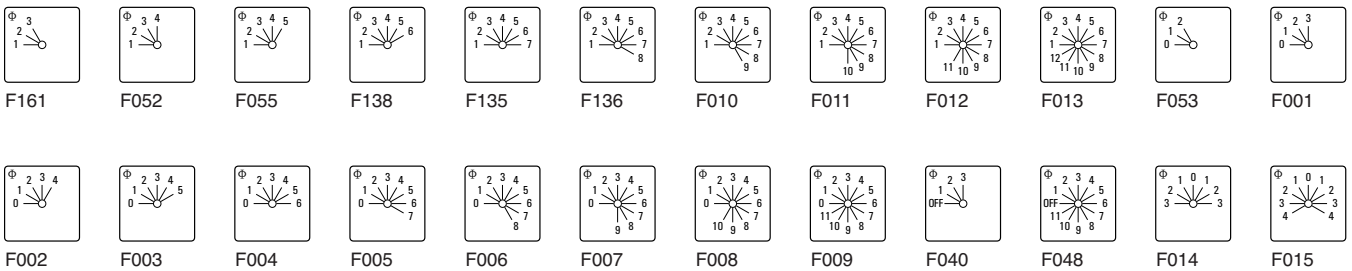

45° switching

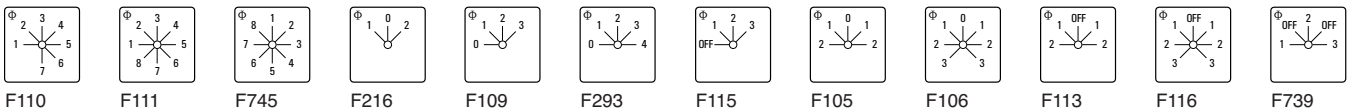

60° switching

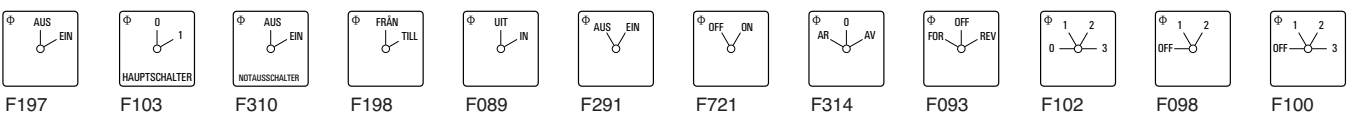

90° switching

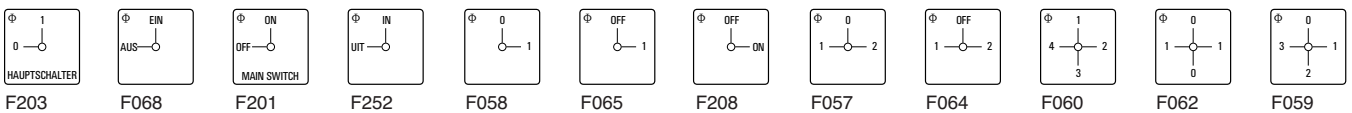

Miscellaneous

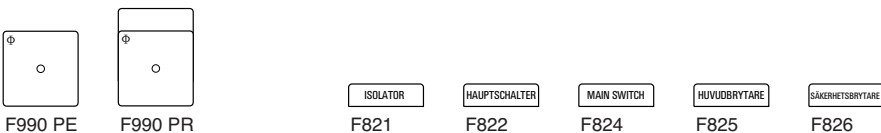



Selection Data	X63	X100	X160	X200	X400	X630
-----------------------	-----	------	------	------	------	------

Rated Insulation Voltage U_i IEC 60947-3, EN 60947-3 ¹ VDE 0660 part 107 ¹ UL/CSA ²	V V	690 600	690 600	690 600	690 600	690 600	690 600
Rated Operational Voltage U_e IEC 60947-3, EN 60947-3 ¹ VDE 0660 part 107 ¹ UL/CSA ²	V V	500 600	500 600	500 600	500 600	500 600	500 600
Rated Impulse Withstand Voltage U_{imp} ¹	kV	6	6	6	6	6	6
Rated Thermal Current I_U/I_{th} IEC 60947-3, EN 60947-3 VDE 0660 part 107 Ambient temp. +35 °C during 24 hours with peaks up to +40 °C Ambient temp. +55 °C during 24 hours with peaks up to +60 °C UL/CSA ²	A A A	80 63 80/63	125 100 150/100	180 150 180/160	240 200 250/200	450 400 400	630 560 630
Rated Operational Current I_e AC-20A No-load operation ³ IEC 60947-3, EN 60947-3 VDE 0660 part 107 500 V Occasional switching under load $\cos \varphi 0,8$ (AC-20B) ³ 3 phase, 3 pole and 440 V 1 phase, 2 pole 500 V AC-21B Switching of resistive loads, including moderate overloads 3 phase, 3 pole and 1 phase, 2 pole 500 V Interrupting Rating UL/CSA ² 600 V	A A A A A	80 80 80 63 63	125 125 125 100 100	180 125 100 80 63/80	240 240 240 200 150/200	450 300 250 200 150/200	630 300 250 200 150/200
Short Circuit Protection Max. fuse size (gL-characteristic) Rated short-time withstand current (1 s-current)	A kA	80	125	200	250 on request	500	630
DC Switching Capacity No. of series contacts 1 2 3 4 5 6 8 Voltage V	A A	63 11 2,2	100 15 2,5	80 12 2,5	200 22 -	220 25 -	- - -
Inductive loads T = 50 ms	A	63 18 6 1,8	100 25 7 2	80 20 7 2	200 32 8 -	220 35 - -	- - - -
Terminals - Use copper wire only connection screw length	for Ø mm	M6 15	M8 16	M10 20	M10 20	M12 30	M16 30
Ambient Temperature of Stages ⁴		55 °C during 24 hours with peaks up to 60 °C at 100 % load, permissible load see Rated Thermal Current I_U/I_{th} .					

¹Valid for lines with grounded common neutral termination, overload category III, pollution degree 3. Values for other supply systems on request.
²International Standards and Approvals, refer to page 15. ³Valid for ambient temperature max. 35 °C. ⁴For electromagnetic optional extras see additional data in Catalog 101.

International Standards and Approvals

Country	Authority	Mark or Standard	X63	X100	X160	X200	X400	X630
USA	Underwriters Laboratories		●	●	●	●	●	●
Canada	Canadian Standards Association		●	●	●	●	●	●
Switzerland	Schweizerischer Elektrotechnischer Verein		+	+	+	+	+	+
Federal Republic of Germany	Verband Deutscher Elektrotechniker	VDE 0660 ¹	+	+	+	+	+	+
Great Britain	British Standards Institution	BS EN 60947 ¹	+	+	+	+	+	+
International Electrical Commission (IEC) Recommendation		IEC 60947 ²	+	+	+	+	+	+
Europäisches Komitee für Elektrotechnische Normung (CENELEC)		EN 60947 ²	+	+	+	+	+	+

● Switch approved

+ Switch conforms to requirements

¹Industrial switchgear is not required to bear a symbol but must conform to requirements. By referring to the specific specification on the product the manufacturer implies that these requirements have been met.

²IEC and CENELEC do not operate an approval scheme.

Dimensions mm
 inch

Escutcheon Plates and Handles	Size	A	B	C	D1ø	D2ø	Escutcheon Plates and Handles	Size	A	B	C	D1ø	D2ø
-------------------------------	------	---	---	---	-----	-----	-------------------------------	------	---	---	---	-----	-----

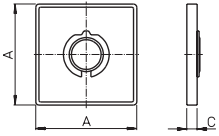
PE-Escutcheon Plate	Size	A	B	C	D1ø	D2ø		Size	A	B	C	D1ø	D2ø
	S2	88		8,5									
		3.46		.34									
	S3	130		10									
		5.12		.39									

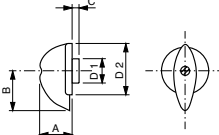
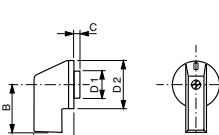
R-Handle	Size	A	B	C	D1ø	D2ø	I-Griff	Size	A	B	C	D1ø	D2ø
	S2	30	42	5	25,4	50		S2	35	43,8	5	25,4	50
		1.18	1.65	.20	1	1.97			1.38	1.72	.20	1	1.97
	S3	47	63	5	37	77,6		S3	54	64,8	5	37	77,6
		1.85	2.48	.20	1.46	3.06			2.13	2.55	.20	1.46	3.06

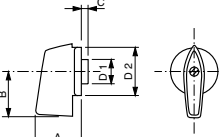
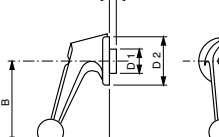
F-Handle	Size	A	B	C	D1ø	D2ø	K-Handle	Size	A	B	C	D1ø	D2ø
	S2	44,7	45	5	25,4	50		S2	55	71	5	25,4	50
		1.76	1.77	.20	1	1.97			2.17	2.80	.20	1	1.97
								S3	75	106	5	37	77,6
									2.95	4.18	.20	1.46	3.06

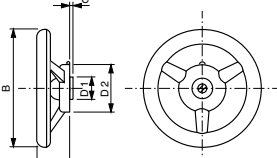
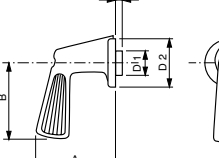
Handwheel	Size	A	B	C	D1ø	D2ø	P-Handle	Size	A	B	C	D1ø	D2ø
	S3	55	200	5	37	79,5		S2	70	68	5	25,4	50
		2.17	7.87	.20	1.46	3.13			2.76	2.68	.20	1	1.97
								S3	81	85	5	37	77,6
									3.19	3.35	.20	1.46	3.06

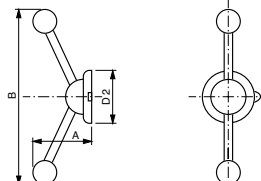
Capstan Handle	Size	A	B	C	D1ø	D2ø		Size	A	B	C	D1ø	D2ø
	S3	110	350			74							
		4.33	13.78			2.91							

Dimensions mm
 inch

Four Hole Panel Mounting

X63 X100 X200

E, EF

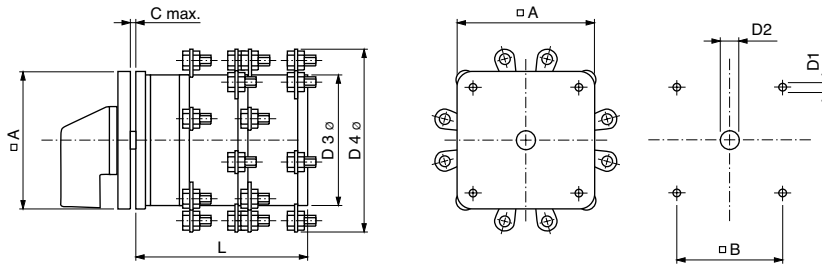

A	88 3.46	130 5.12	130 5.12
B	68 2.68	104 4.09	104 4.09
C	7.5 .30	4.5 .18	4.5 .18
D1	6 .24	7 .28	7 .28
D2	13-17 .51-.67	15.5-20 .61-.79	15.5-20 .61-.79
D2	26-30 1.02-1.18	22-25 .87-.98	22-25 .87-.98
D3	84 3.31	128 5.04	128 5.04
D4	120 4.72	170 6.69	188 7.40

No. of stages		1	2	3	4	5	6
X63	mm	72.5	110.5	148.5	186.5	224.5	262.5
	inch	2.85	4.35	5.85	7.34	8.84	10.33
X100	mm	84	128	172	216	260	304
	inch	3.31	5.04	6.77	8.5	10.24	11.97
X200	mm	90	140	190	240	290	340
	inch	3.54	5.51	7.48	9.45	11.42	13.39

ER, ERF

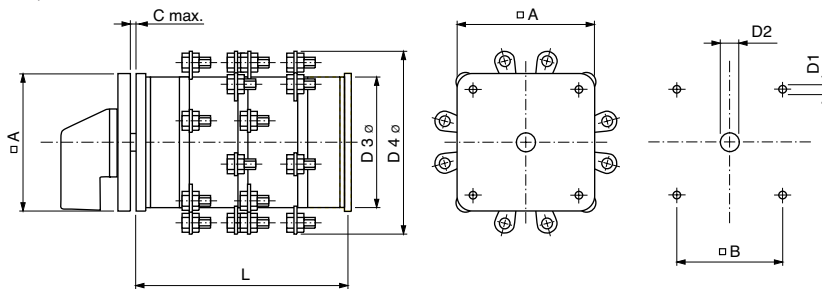

A	88 3.46	130 5.12	130 5.12
B	68 2.68	104 4.09	104 4.09
C	5.5 .22	7 .28	7 .28
D1	6 .24	7 .28	7 .28
D2	13-17 .51-.67	15.5-20 .61-.79	15.5-20 .61-.79
D2	26-30 1.02-1.18	22-25 .87-.98	22-25 .87-.98
D3	84 3.31	128 5.04	128 5.04
D4	120 4.72	170 6.69	188 7.40

No. of stages		1	2	3	4	5	6
X63	mm	100	138	176	214	252	290
	inch	3.93	5.43	6.93	8.42	9.92	11.41
X100	mm	116	160	204	248	292	336
	inch	4.57	6.3	8.03	9.76	11.5	13.23
X200	mm	122	172	222	272	322	372
	inch	4.8	6.77	8.74	10.71	12.68	14.65

VE

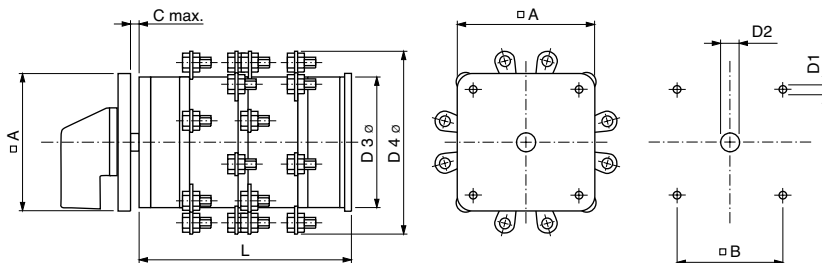

A	88 3.46	130 5.12	130 5.12
B	68 2.68	104 4.09	104 4.09
C	16 .63	19.3 .76	19.3 .76
D1	6 .24	7 .28	7 .28
D2	13-17 .51-.67	15.5-20 .61-.79	15.5-20 .61-.79
D3	84 3.31	128 5.04	128 5.04
D4	120 4.72	170 6.69	188 7.40

No. of stages		1	2	3	4	5	6
X63	mm	99.5	137.5	175.5	213.5	251.5	289.5
	inch	3.91	5.41	6.91	8.4	9.9	11.39
X100	mm	115.5	159.5	203.5	247.5	291.5	335.5
	inch	4.55	6.28	8.01	9.74	11.48	13.21
X200	mm	121.5	171.5	221.5	271.5	321.5	371.5
	inch	4.78	6.75	8.72	10.69	12.66	14.63

Dimensions mm
inch

Four Hole Panel Mounting **X160** **X400**

E, EF

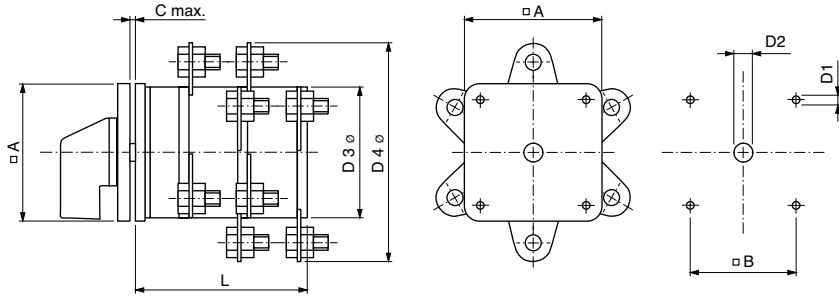

A	88 3.46	130 5.12
B	68 2.68	104 4.09
C	7,5 .3	4,5 .18
D1	6 .24	7 .28
D2 E	13-17 .51-.67	15,5-20 .61-.79
D2 EF	26-30 1.02-1.18	22-25 .87-.98
D3	84 3.31	128 5.04
D4	142 5.59	200 7.87

No. of stages		1	2	3	4	5	6
X160	mm	72,5	110,5	148,5	186,5	224,5	262,5
	inch	2.85	4.35	5.85	7.34	8.84	10.33
X400	mm	90	140	190	240	290	340
	inch	3.54	5.51	7.48	9.45	11.42	13.39

ER, ERF

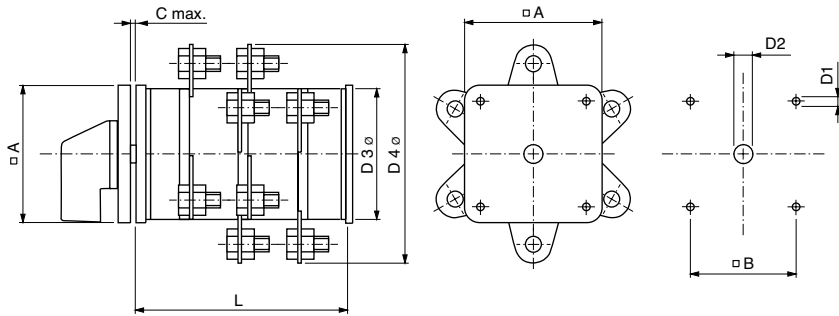

A	88 3.46	130 5.12
B	68 2.68	104 4.09
C	5,5 .22	7 .28
D1	6 .24	7 .28
D2 E	13-17 .51-.67	15,5-20 .61-.79
D2 ERF	26-30 1.02-1.18	22-25 .87-.98
D3	84 3.31	128 5.04
D4	142 5.59	200 7.87

No. of stages		1	2	3	4	5	6
X160	mm	100	138	176	214	252	290
	inch	3.93	5.43	6.93	8.42	9.92	11.41
X400	mm	122	172	222	272	322	372
	inch	4.8	6.77	8.74	10.71	12.68	14.65

VE

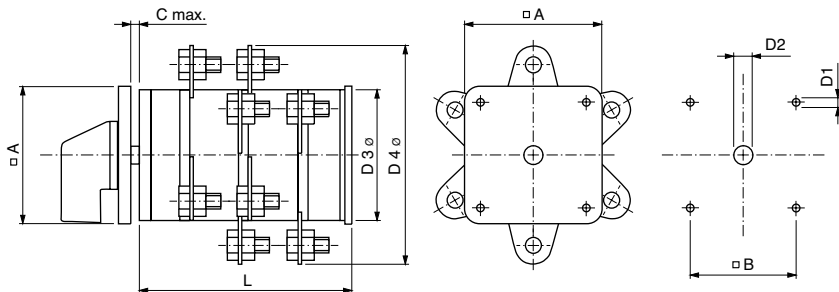

A	88 3.46	130 5.12
B	68 2.68	104 4.09
C	16 .63	19,3 .76
D1	6 .24	7 .28
D2	13-17 .51-.67	15,5-20 .61-.79
D3	84 3.31	128 5.04
D4	142 5.59	200 7.87

No. of stages		1	2	3	4	5	6
X160	mm	99,5	137,5	175,5	213,5	251,5	289,5
	inch	3.91	5.41	6.91	8.4	9.9	11.39
X400	mm	121,5	171,5	221,5	271,5	321,5	371,5
	inch	4.78	6.75	8.72	10.69	12.66	14.63

Dimensions mm
 inch

Four Hole Panel Mounting **X630**

E, EF

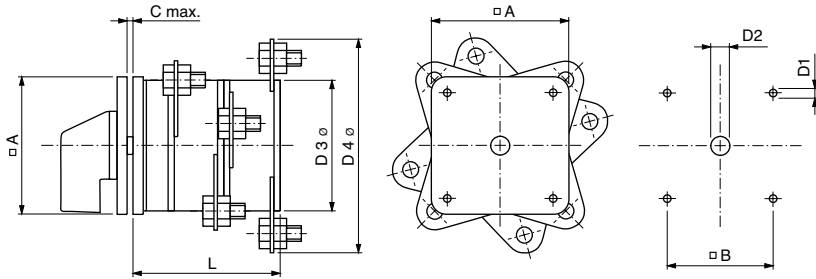

A	130	
	5.12	
B	104	
	4.09	
C	4.5	
	.18	
D1	7	
	.28	
D2	E	15.5-20
		.61-.79
D2	EF	22-25
		.87-.98
D3	128	
	5.04	
D4	218	
	8.58	

No. of stages		1	2	3	4	5	6
X630	mm	90	146	202	258	314	370
	inch	3.54	5.75	7.95	10.16	12.36	14.57

ER, ERF

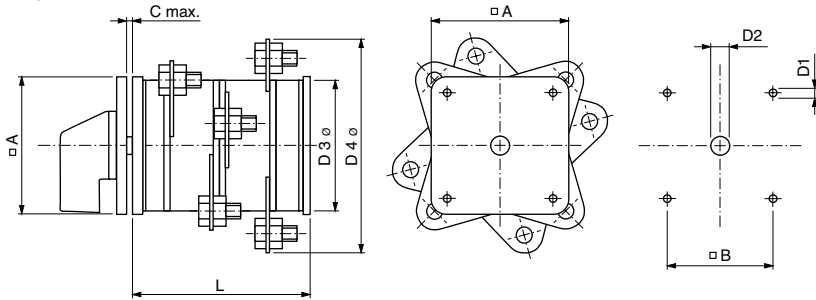

A	130	
	5.12	
B	104	
	4.09	
C	7	
	.28	
D1	7	
	.28	
D2	ER	15.5-20
		.61-.79
D2	ERF	22-25
		.87-.98
D3	128	
	5.04	
D4	218	
	8.58	

No. of stages		1	2	3	4	5	6
X630	mm	122	178	234	290	346	402
	inch	4.8	7.01	9.21	11.42	13.62	15.83

VE

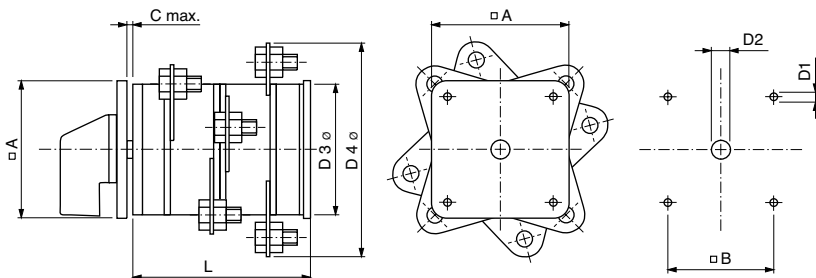

A	130
	5.12
B	104
	4.09
C	19.3
	.76
D1	7
	.28
D2	15.5-20
	.61-.79
D3	128
	5.04
D4	218
	8.58

No. of stages		1	2	3	4	5	6
X630	mm	121.5	177.5	233.5	289.5	345.5	401.5
	inch	4.78	6.99	9.19	11.4	13.6	15.81