

Flat Capacitive Prox

E2K-F

Flat-Pack, Thin Rectangular Plastic DC Sensor Fits Space-Confined Installations

- Non-contact detection of metallic and non-metallic targets including water, oil, glass, plastic and wood
- Detects level inside non-metallic containers
- Thin, 10 mm (0.39 inch) plastic body is ideal for conveyor wall mounting
- Unshielded sensor has LED indicator and fixed sensitivity for simple installation
- Built-in DC amplifier provides NPN switching of loads to 100 mA



Ordering Information

■ SENSORS

Type	Unshielded	
Nominal detecting distance	10 mm (0.39 in)	
Output type	NPN-NO open collector	NPN-NC open collector
Part number	E2K-F10MC1	E2K-F10MC2

Specifications

Part number		E2K-F10MC1	E2K-F10MC2
Sensor Type		Capacitive	
Body	Style	Flat rectangular	
	Type	Unshielded	
Supply voltage		10 to 30 VDC	
Current consumption		10 mA max.	
Detectable object type		Metallic and non-metallic objects	
Sensitivity		Fixed	
Effective maximum detecting distance with standard target		10 mm (0.39 in)	
Standard target size (grounded mild steel, L x W x H)		50 x 50 x 1 mm (2.0 x 2.0 x 0.04 in)	
Differential travel		15% max. of effective maximum detecting distance	
Control output	DC solid-state	Type	NPN-NO open collector NPN-NC open collector
		Max. load	100 mA
		Max. on-state voltage drop	1.5 VDC
Response frequency		100 Hz	
Circuit protection	Output short-circuit	Not provided	
	DC power supply reverse polarity	Provided	
	Weld field immunity	Not provided	
	RFI immunity	Not provided	
Indicators		Target Present (red LED)	
Materials	Housing	ABS	
	Sensing face	ABS	
Mounting		Bottom surface with two through holes	
Connections	Prewired	3-conductor cable, 2 m (6.56 ft) length	
Weight with cable		Approx. 35 g (1.2 oz)	
Enclosure ratings	UL	—	
	NEMA	1, 4, 12, 13	
	IEC 144	IP66	
Approvals	UL	—	
	CSA	—	
Ambient operating temperature		-10°C to 55°C (14°F to 131°F)	
Vibration		10 to 55 Hz, 1.5 mm (0.06 in) double amplitude	
Shock		Approx. 50 G	

Operation

OUTPUT CIRCUIT DIAGRAM

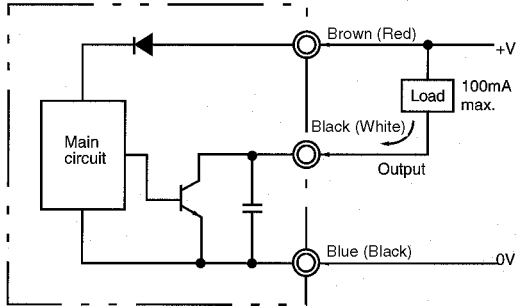

Note: IEC colors are shown in parenthesis.

TIMING CHARTS

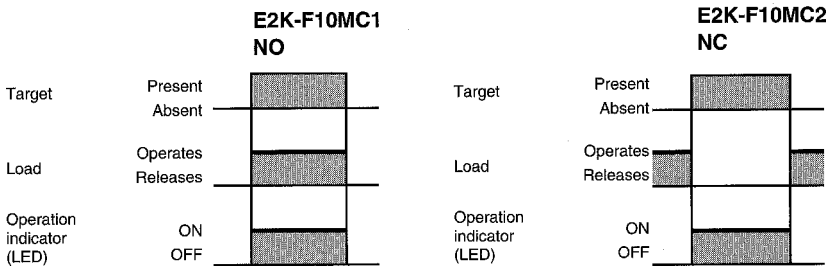

CONNECTIONS

Directly Switching a Relay or Photocoupler

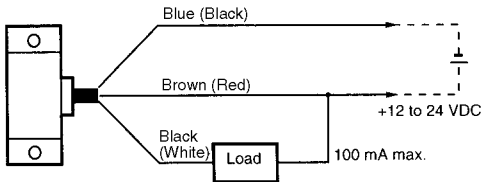

Note: IEC colors are shown in parentheses.

Using the Switch Output as a Solid-State Input

When connecting the sensor to CMOS IC or TTL, provide an interface circuit as shown here, and connect it to the solid-state circuit of the the following stage.

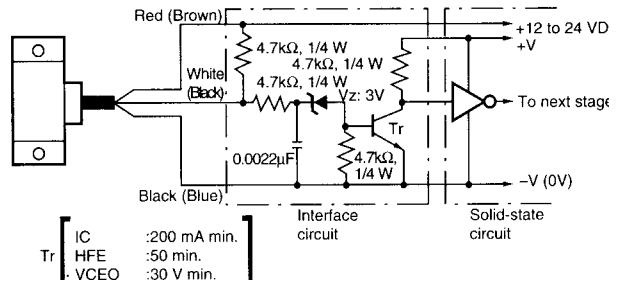

Engineering Data

Operating Range

Target crosses perpendicular to wide face of sensor

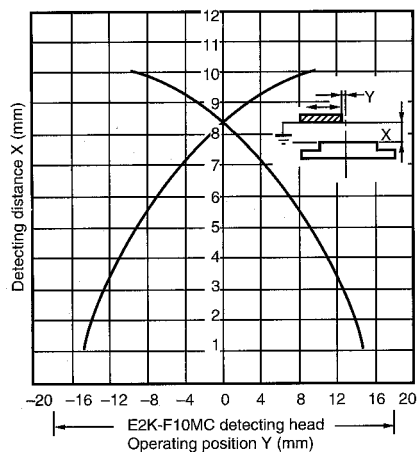

Target crosses perpendicular to narrow face of sensor

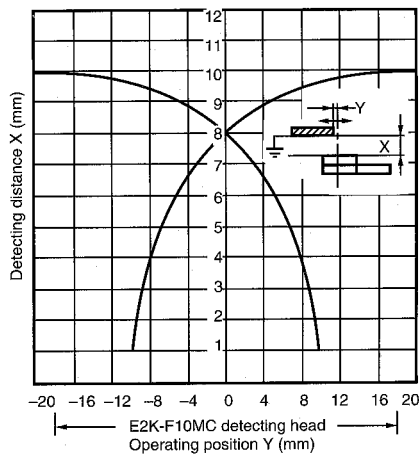

Detecting Distance vs. Size and Material of Target

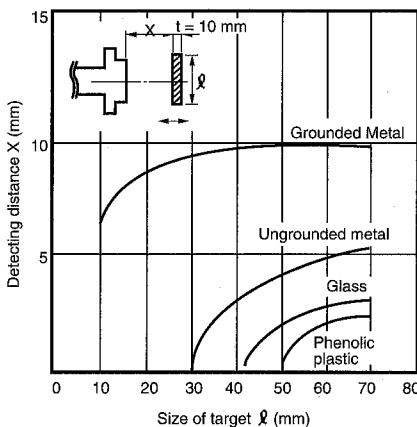
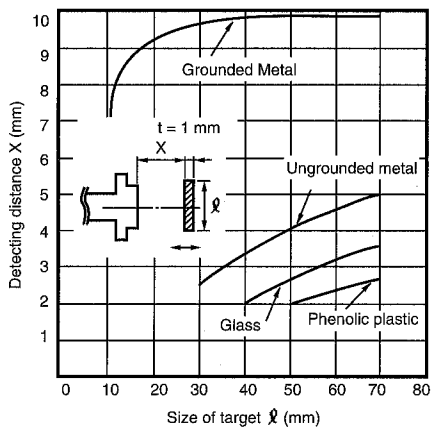

Note: The detecting distance decreases when detecting targets such as ungrounded metals and dielectrics.

Detecting Distance vs. Thickness and Material of Target

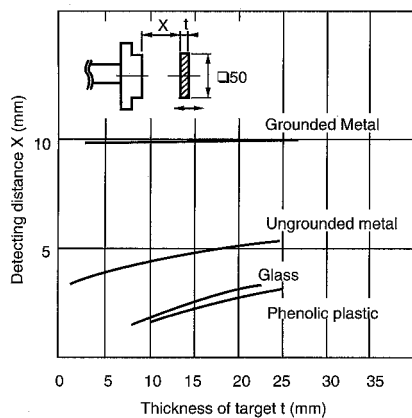

Dimensions

Unit: mm (inch)

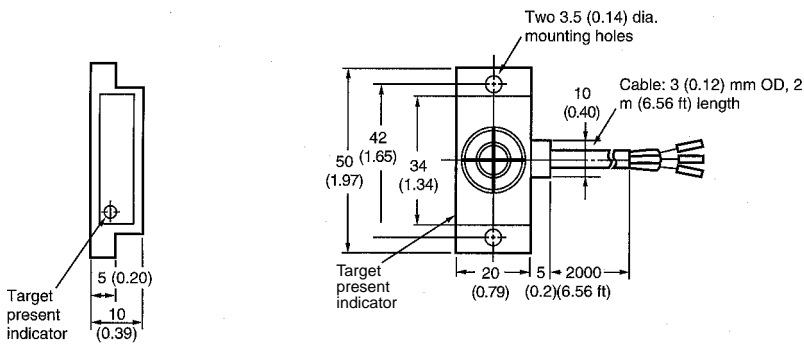

Mounting holes

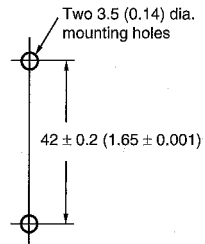

Precautions

■ EFFECTS OF SURROUNDING METALS

When mounting E2K-F proximity sensors onto a metallic wall, metallic object or metallic mounting plate, be sure to provide the minimum distances shown here to prevent the sensor from detecting objects other than the target.

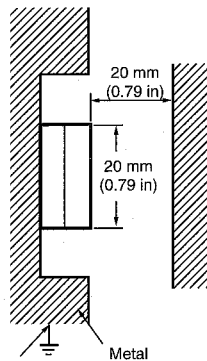

Be sure to ground the metallic panel or object to prevent switch malfunction.

Top view

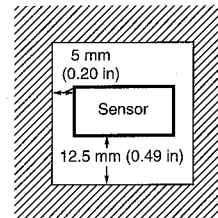

■ MUTUAL INTERFERENCE

When mounting two or more proximity sensors in opposed or parallel positions, be sure to space the sensors at a distance greater than that shown here to prevent mutual interference.

Face to face

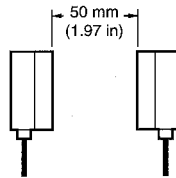

Side by side

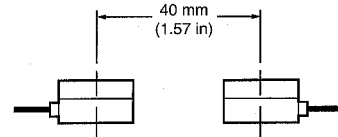

■ MATERIAL OF TARGET

E2K-F10MC proximity sensors detect almost all kinds of targets. However, the detecting distance varies depending on electric characteristics (conductive constant, dielectric constant), grade of water absorbed and volume of each target. The detecting distance for grounded metals is longer than that for other kinds of targets.

■ MAXIMUM CABLE LENGTH

The cable length does not cause variation of the operating characteristics of the sensor. However, to avoid voltage drop, the maximum length of the cable used with the sensor should be 100 m (328 ft).

■ USING METAL CONDUIT

If a high voltage or power line runs near the proximity sensor cable, be sure to wire the sensor cable through a metal conduit to protect the sensor from malfunctioning or damage.

OMRON

OMRON ELECTRONICS LLC

One East Commerce Drive
Schaumburg, IL 60173

1-800-55-OMRON

Cat. No. CEDSAX4

11/01

OMRON ON-LINE

Global - <http://www.omron.com>
USA - <http://www.omron.com/oei>
Canada - <http://www.omron.com/oci>

Specifications subject to change without notice.

OMRON CANADA, INC.

885 Milner Avenue
Scarborough, Ontario M1B 5V8

416-286-6465

Printed in the U.S.A.